

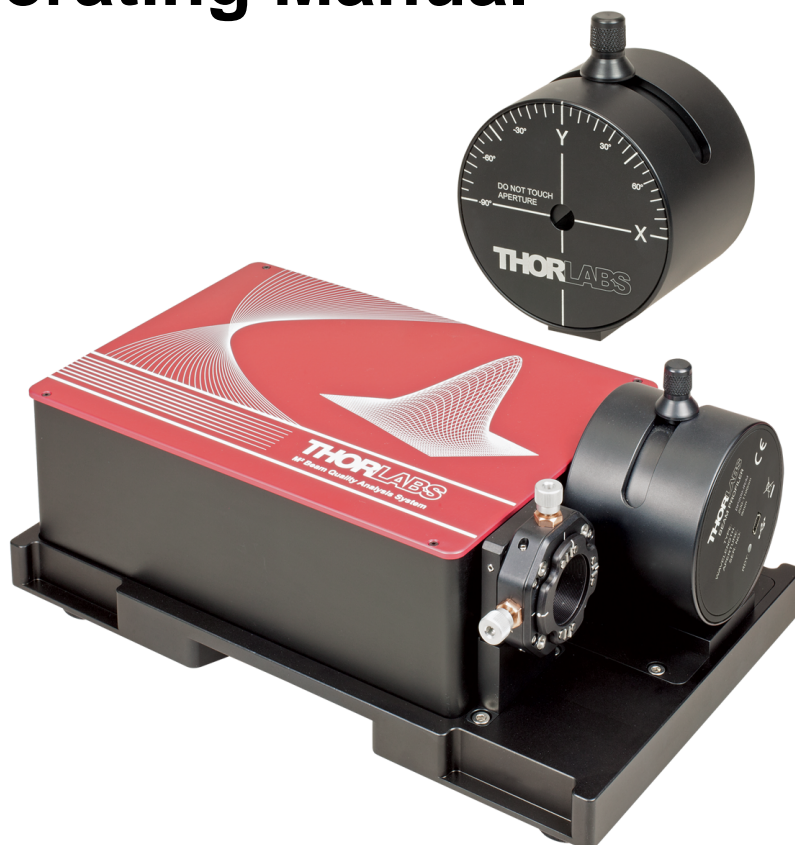

Thorlabs Beam Beam Analyzing Software

**BP209-VIS(/M), BP209IR1(/M),
and BP209-IR2(/M)
with M2MS(-AL)**

Operating Manual



2022

Version: 8.1
Date: 14-Feb-2022

Contents

Foreword	5
1 General Information	6
1.1 Ordering Codes and Accessories	6
1.2 Requirements	7
2 Getting Started	8
2.1 Parts List BP209-VIS(/M), BP209IR1(/M) and BP209-IR2(/M)	8
2.2 Parts List M2MS with BP209 Series	8
3 Operating Elements	10
3.1 BP209 Series	10
3.1.1 Rotation Mount	11
3.2 Mounting BP209 Series	12
4 Installation	13
4.1 Software Installation	13
4.2 Connection to the PC	13
4.3 Start the Application	14
5 Operating Principle	15
6 The Graphics User Interface (GUI)	16
6.1 Menu Bar	17
6.1.1 File Menu	17
6.1.2 Control Menu	18
6.1.3 Options Menu	19
6.1.4 Windows Menu	22
6.1.5 View Menu	22
6.1.6 Help Menu	23
6.2 Tool Bar	24
6.3 Status Bar	25
6.4 Save Settings	25
6.5 Beam Settings	26
6.5.1 Optical Setup	27
6.5.1.1 Wavelength	27
6.5.1.2 Power Correction	28
6.5.2 Beam Profiler Information	29
6.5.3 Slit Beam Profiler Parameter	30
6.5.3.1 Gain, Bandwidth and Baseline	31
6.5.3.2 Scan Rate	31
6.5.3.3 Miscellaneous	32
6.5.4 Calculation Parameter	32
6.5.4.1 Calculation Area	33

6.5.4.2	Averaging Mode	34
6.5.4.3	Clip Level	35
6.5.4.4	Hold Maximum	35
6.5.4.5	Autoscale to Peak	35
6.5.4.6	Correct Beam Width	35
6.5.4.7	Reference Position	35
6.5.4.8	Unit	36
6.5.5	Plot Over Time Parameter	36
6.5.6	Translation Stage Control	37
6.6	Child Windows	39
6.6.1	2D Reconstruction	40
6.6.2	3D Profile	42
6.6.3	X and Y Profiles	43
6.6.4	Zooming and Panning Diagrams	44
6.6.5	Calculation Results	45
6.6.6	Manual Vergence Measurement	49
6.6.7	Tuning View	51
6.6.8	Beam Overlapping	53
6.6.9	Plots	55
6.6.9.1	Plot Positions	56
6.6.9.2	Plot Power	57
6.6.9.3	Plot Diameters	58
6.6.9.4	Plot Gaussian Fit	58
6.6.9.5	Plot Environment Data	60
6.6.9.6	Beam Stability	61
7	Operation Instructions	63
7.1	Measurement with the Beam Profiler	63
7.1.1	Operating the Instrument	63
7.1.2	Pass/Fail Test	65
7.1.3	Save Measurement Results	66
7.1.3.1	Export Device Data	67
7.1.3.2	Print Windows	69
7.1.3.3	Save Test Protocol	70
7.1.4	Pulsed Laser Sources	72
7.1.5	Knife Edge Mode	74
7.2	Beam Quality (M ²) Measurement	77
7.2.1	General	77
7.2.2	M2MS Operating Principle	79
7.2.3	Beam Diameter Requirements	80
7.2.4	M ² Meter Extension Set	81
7.2.5	M ² Meter Set with BP209 Slit Beam Profiler	82
7.2.6	Setup M2MS	83

7.2.6.1	Mounting the Beam Profiler	85
7.2.6.2	Connecting M2MS to the PC	86
7.2.7	M ² Measurement	87
7.2.7.1	Beam Alignment	88
7.2.7.2	M ² Measurement Panel	97
7.2.7.3	M ² Settings	99
7.2.7.4	Saving the M ² Measurement Results	101
7.2.7.5	Running the M ² Measurement	105
7.2.7.6	M ² Measurement Results	106
7.2.7.7	M ² Troubleshooting	111
7.2.7.8	Live Adjustment	114
7.2.8	Divergence Measurement	115
7.2.8.1	Beam Alignment	115
7.2.8.2	Divergence Measurement Panel	123
7.2.8.3	Divergence Measurement Settings	125
7.2.8.4	Saving the Divergence Measurement Results	126
7.2.8.5	Running the Divergence Measurement	126
7.2.8.6	Divergence Measurement Results	127
7.2.8.7	Live Adjustment	129
7.2.9	M ² Theory	130
8	Write Your Own Application	133
8.1	32 bit Operating System	134
8.2	64 bit Operating System	136
9	Maintenance and Repair	138
9.1	Version and Other Information	138
9.2	Cleaning	138
9.3	Troubleshooting	139
9.3.1	Warnings and Errors	140
10	Application Note	141
10.1	Coordinate Systems	141
10.2	Raw Data Measurements	141
10.3	Ellipse (Fitted)	142
10.4	X-Y-Profile Measurement	143
10.5	Gaussian Fit Measurement	143
10.6	Bessel Fit	144
11	Appendix	145
11.1	Technical Data BP209 Series	145
11.2	Technical Data M2MS-BP209	146
11.3	Technical Data M2MS Extension Sets	147
11.4	Typical Photodiode Response Curves	148
11.5	Power Ranges	150

11.6	Initial Settings _____	151
11.7	Drawing BP209 _____	152
11.8	Slit and Photodiode Position _____	154
11.9	Drawing BP209 Mounting Adapter _____	155
11.10	Drawing M2MS-BP209 _____	156
11.11	Compatibility with Older Hardware _____	157
11.12	List of Acronyms _____	158
11.13	Safety _____	159
11.14	Certifications and Compliances _____	160
11.15	Return of Devices _____	161
11.16	Manufacturer Address _____	161
11.17	Warranty _____	161
11.18	Exclusion of Liability and Copyright _____	161
11.19	Thorlabs Worldwide Contacts _____	162

We aim to develop and produce the best solution for your application in the field of optical measurement technique. To help us to live up to your expectations and constantly improve our products we need your ideas and suggestions. Therefore, please let us know about possible criticism or ideas. We and our international partners are looking forward to hearing from you.

Thorlabs GmbH

Warning

Sections marked by this symbol explain dangers that might result in personal injury or death. Always read the associated information carefully, before performing the indicated procedure.

Attention

Paragraphs preceded by this symbol explain hazards that could damage the instrument and the connected equipment or may cause loss of data.

Note

This manual also contains "NOTES" and "HINTS" written in this form.

Please read this advice carefully!

1 General Information

The BP209 Series Thorlabs Dual Scanning Slit Beam Profilers are ideal for analyzing cross sectional profiles of near-Gaussian laser beams and can be operated in scanning-slit or knife-edge modes. The beam diameter is measured in accordance with the ISO 11146 standard and can be displayed using a number of industry-standard clip levels or an arbitrary clip level set by the user. When the beam of interest does not have a near-Gaussian beam shape, or when single-shot measurements of pulsed beams are required, we recommend the Thorlabs [BC207 CMOS Camera Beam Profilers](#).

With the BP209 beam profiler, measurements of the intensity profiles along the user-specified X and Y axes of the beam's cross section are acquired at scan rates between 2 Hz and 20 Hz. Scan rates can be set in the Beam Software. The fast 20 Hz scan rate enables real-time optical system alignment. Primarily intended for CW laser beams, >10 Hz pulsed beams can also be measured using an averaging technique.

These measurements can be used for beam quality evaluation, examination of the reconstructed beam profile, and monitoring long-term stability.

Three BP209 Dual Scanning Slit beam profiler models are available with different wavelength ranges: BP209-VIS(/M), BP209IR1(/M), and BP209-IR2(/M). Each can be purchased as a metric or imperial version. For the purpose of this manual, the versions are referred to as BP209xxx(/M).

The Beam Software versions 8.0 and higher support the BP209 Beam Profiler. The Beam Software is provided for download from the software tab on the [Thorlabs website](#).

To convert Thorlabs beam profilers into a M² measurement system, Thorlabs offers the [M2MS\(-AL\) extension sets](#). For more information please visit the Thorlabs website.

1.1 Ordering Codes and Accessories

BP209-VIS	Slit Beam Profiler, 200 - 1100 nm, 9 mm aperture, 5 and 25 μ m slits, imperial version
BP209-VIS/M	Slit Beam Profiler, 200 - 1100 nm, 9 mm aperture, 5 and 25 μ m slits, metric version
BP209IR1	Slit Beam Profiler, 500 - 1700 nm, 9 mm aperture, 5 and 25 μ m slits, imperial version
BP209IR1/M	Slit Beam Profiler, 500 - 1700 nm, 9 mm aperture, 5 and 25 μ m slits, metric version
BP209-IR2	Slit Beam Profiler, 900 - 2700 nm, 9 mm aperture, 5 and 25 μ m slits, imperial version
BP209-IR2/M	Slit Beam Profiler, 900 - 2700 nm, 9 mm aperture, 5 and 25 μ m slits, metric version

M² Measurement System with Slit Beam Profiler

The M2MS-BP209 comprises the M2MS Extension and a mounted BP209 Beam Profiler. The following models are available:

Item Number	Description
M2MS-BP209VIS-AL	M2 Measurement System with BP209-VIS, 250 - 600 nm
M2MS-BP209VIS-AL/M	M2 Measurement System with BP209-VIS, 250 - 600 nm, metric
M2MS-BP209VIS	M2 Measurement System with BP209-VIS, 400 - 1100 nm
M2MS-BP209VIS/M	M2 Measurement System with BP209-VIS, 400 - 1100 nm, metric
M2MS-BP209IR2	M2 Measurement System with BP209-IR2, 900 - 2700 nm
M2MS-BP209IR2/M	M2 Measurement System with BP209-IR2, 900 - 2700 nm, metric

Please visit our homepage <http://www.thorlabs.com> for further information.

1.2 Requirements

These are the requirements for the PC intended to be used for operation of the BP209 Series of slit beam profilers using the Thorlabs Beam Software V8.0 or higher. Please find the BEAM Software for download from the [Beam Software website](#).

Hardware Requirements

- Processor (CPU): ≥ 3.0 GHz Intel Core (i5 or Higher)¹
- Memory (RAM): 4.0 GB
- Graphic Card Resolution: OpenGL (specification GLX 1.3 up) compatible graphics adapter:
 - Radeon (X100 series ≥ X850, X1000 series ≥ X1600, HD series ≥ 2400)
 - Geforce 7 series ≥ 7600, 8 series ≥ 8500, 9 series ≥ 9600
 - Quadro FX series ≥ FX770M
- Hard Drive: Min. 2 GB of available disk space
- Interface: Free USB 2.0 port
- Monitor resolution minimum 1024 x 758 pixel (≥ 16 bit color depth)

¹) Intel Core i3 processors and mobile versions of Intel processors may not satisfy the requirements.

The Thorlabs Beam Software is compatible with the following operating systems:

- Windows® 8.1 (32-bit or 64-bit)
- Windows® 10 (32-bit or 64-bit)

Recommended for Optimal Performance:

- USB 2.0 port
- Processor: Intel Core 2 i5 or AMD Ryzen 5 (min. 3.0 GHz), 8.0 GB RAM
- OpenGL (specification GLX 1.3 up) compatible graphics adapter:
 - Radeon HD series ≥ 7000
 - Geforce GTX series ≥ 500

2 Getting Started

Please inspect the shipping container for damage. Please do not cut through the cardboard. You might need the box for storage or for returns.

If the shipping container seems to be damaged, keep it until you have inspected the contents for completeness and tested the BP209 Series device mechanically and electrically.

Verify that you have received the following items within the package:

2.1 Parts List BP209-VIS(/M), BP209IR1(/M) and BP209-IR2(/M)

- 1 BP209 Series Beam Profiler Instrument as an External Measurement Head with Dust Cover
- 1 USB 2.0 Cable A to Mini B, Length 3.0 m
- Quick Reference

2.2 Parts List M2MS with BP209 Series

If you have purchased an M² measurement system consisting of the M2MS Extension Set with the BP209 Series Beam Profiler, the package will contain the following items:

1. M2MS-BP209VIS-AL(/M)

- M2MS-BP209VIS-AL (/M) Measurement System with mounted BP209-VIS (/M) Slit Beam Profiler
- Power supply 100 to 240 V AC / 15 V 3 A DC
- Cable USB 2.0 A to Mini B, 3 m length
- Cable USB 2.0 A to Mini B, angled, 0.5 m length
- 1 pcs. 0.05" Hex Key
- M2MS Accessory Box UV, that includes:
 - 1 pcs. LA4158-UV Plano Convex Lens, f = 250 mm, UV AR coating
 - 1 pcs. LA1461-A Plano Convex Lens, f = 250 mm, AR coating 350 - 700 nm
 - 4 pcs. CL6 Rail clamps
 - 1 pcs. M2MS Adjustment laser
 - 1 pcs. Ball Driver 3 mm
 - 1 pcs. spare screw M4x10
- Quick Reference

2. M2MS-BP209VIS(/M)

- M2MSBP-209VIS (/M) Measurement System with mounted BP209-VIS (/M) Slit Beam Profiler
- Power supply 100 to 240 V AC / 15 V 3 A DC
- Cable USB 2.0 A to Mini B, 3 m length
- Cable USB 2.0 A to Mini B, angled, 0.5 m length
- 1 pcs. 0.05" Hex Key
- M2MS Accessory Box VIS, that includes:
 - 1 pcs. LA1461-A Plano Convex Lens, f = 250 mm, AR coating 350 - 700 nm
 - 1 pcs. LA1461-B Plano Convex Lens, f = 250 mm, AR coating 650 - 1050 nm
 - 1 pcs. LA1461-C Plano Convex Lens, f = 250 mm, AR coating 1050 - 1700 nm
 - 1 pcs. LA5255-D Plano Convex Lens, f = 250 mm, AR coating 1650 - 3000 nm
 - 4 pcs. CL6 Rail clamps

- 1 pcs. M2MS Adjustment laser
- 1 pcs. Ball Driver 3 mm
- 1 pcs. spare screw M4x10
- Quick Reference

4. M2MS-BP209IR2(/M)

- M2MS Measurement System with mounted BP209-IR2(/M) Slit Beam Profiler
- Power supply 100 to 240 V AC / 15 V 3 A DC
- Cable USB 2.0 A to Mini B, 3 m length
- Cable USB 2.0 A to Mini B, angled, 0.5 m length
- 1 pcs. 0.05" Hex Key
- M2MS Accessory Box VIS, that includes:
 - 1 pcs. LA1461-A Plano Convex Lens, $f = 250$ mm, AR coating 350 - 700 nm
 - 1 pcs. LA1461-B Plano Convex Lens, $f = 250$ mm, AR coating 650 - 1050 nm
 - 1 pcs. LA1461-C Plano Convex Lens, $f = 250$ mm, AR coating 1050 - 1700 nm
 - 1 pcs. LA5255-D Plano Convex Lens, $f = 250$ mm, AR coating 1650 - 3000 nm
 - 4 pcs. CL6 Rail clamps
 - 1 pcs. M2MS Adjustment laser
 - 1 pcs. Ball Driver 3 mm
 - 1 pcs. spare screw M4x10
- Quick Reference

3 Operating Elements

3.1 BP209 Series

The components of the BP209-VIS are labeled in the image below. Aside from the mounting thread on the [Mounting Plate](#)¹², BP209-VIS and BP209-VIS/M are identical. BP209IR1(/M) and BP209-IR2(/M) outer dimensions and components are identical to BP209-VIS(/M).

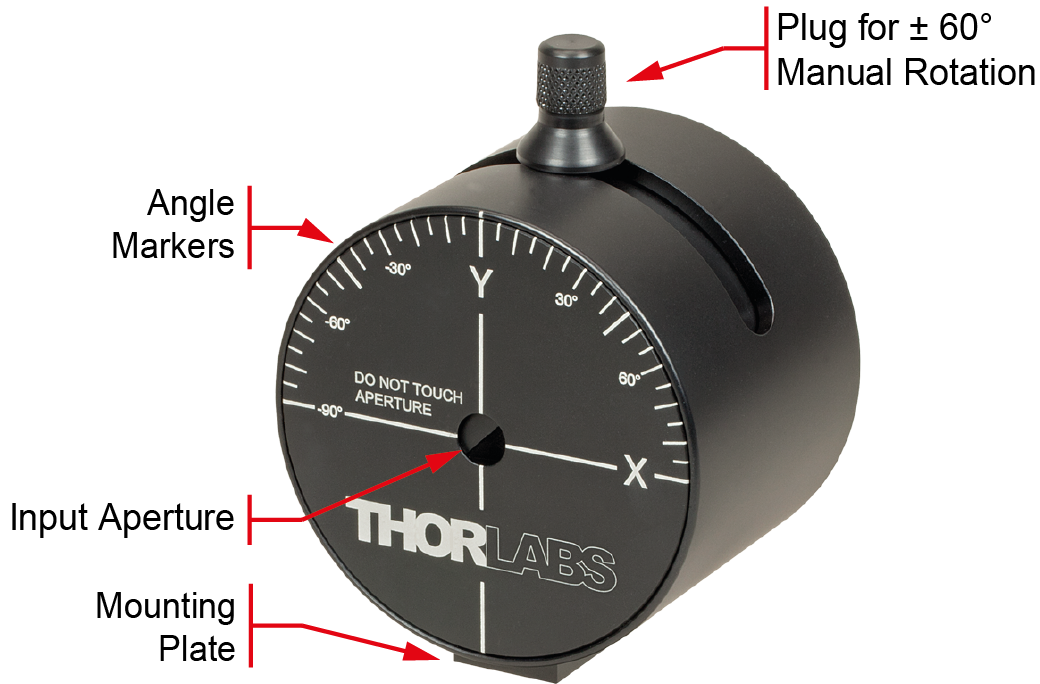

BP209-VIS

3.1.1 Rotation Mount

The BP209 Series Beam Profilers are external optical beam measurement sensors that are designed for free-space applications and come with a rotation mount.

The rotation mount provides up to $\pm 60^\circ$ of manual rotation for the X and Y scan axes. Release the plug on the top and move it to the left or right while keeping the mount fixed - the BP209 Beam Profiler rotates within its outer housing. To arrive at the desired angle use the markers on the front plate. This way the beam profile can be measured at different directions.

Note

For accurate measurement results make sure the beam enters the input aperture perpendicular to the front plane and as close as possible to the center of the aperture.



The rotation capability of the sensor with respect to the beam is essential for correct beam ellipticity measurements.

Since the major and minor axes of an elliptical beam may have arbitrary position in space, the scan axes of the Beam Profiler needs to be oriented to these axes in order to measure the real ellipticity. For the most accurate alignment, it is best to rotate the BP209 while observing the X and Y profiles. Determine the point where the profile width in one axis reaches the minimum and the maximum in the other axis.

Note

Without scan axes alignment the ellipticity measurement may become erroneous!

3.2 Mounting BP209 Series

For mounting the bottom the Beam Profiler has a mounting plate with 2 threaded mounting holes. All metric models have a M4 and a M6 thread and the imperial models have an 8-32 and a 1/4-20 thread.

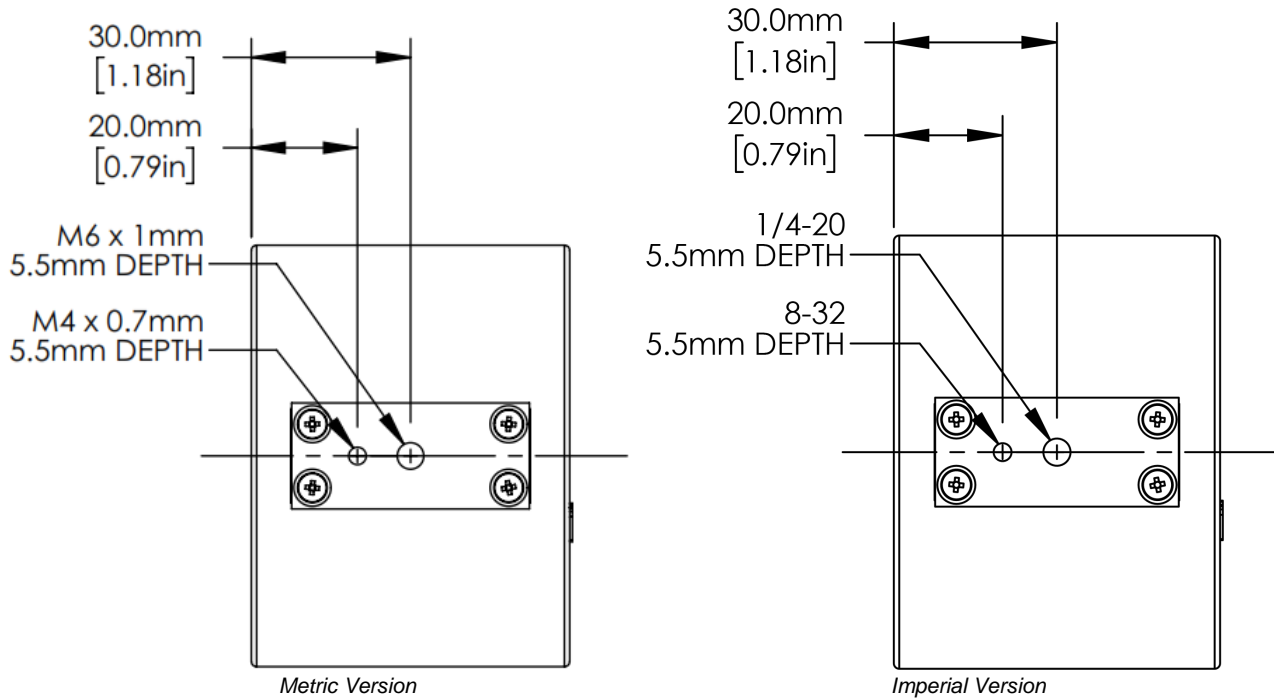

Please mount the BP209 Series Beam Profiler on the optical bench using a Thorlabs [post](#), [post holder](#) and a [base or clamping fork](#).

4 Installation

4.1 Software Installation

The Beam Software can be downloaded from the Thorlabs website:

http://www.thorlabs.com/software_pages/ViewSoftwarePage.cfm?Code=Beam

Please check for updates to the Thorlabs Beam Software and always use the latest Software version.

The Beam software versions 8.0 or higher support the beam profiler series BP209, BC106N, and BC207. Software versions below V8.0 do not support the BC207 Series.

- Save the ZIP file to your computer and unpack the archive. The Install Shield Wizards starts by double-clicking the setup.exe.
- The installation contains 2 main parts - the NI-VISA™ Runtime V17.0 and the Beam Software itself, including drivers and the manual.
- Please read the license agreements carefully, choose "I agree" and click 'Next'.
- Windows Security will ask your confirmation to install the Thorlabs USB driver.
- You may check the box "Always trust software from "Thorlabs GmbH". This will shorten the installation. However, if you do not want to do that, please click the "Install" button. You will then be asked to confirm the installation of further Thorlabs software components. Please install the instrument driver packages as well as the Firmware Loader Driver Package.
- When all drivers are installed, the "Read Me" comes up.
- Click "Next", then "Finish" to complete the software installation.

4.2 Connection to the PC

Connect the BP209 Series Beam Profiler to a USB 2.0 port of your computer. Use only the cable that comes with the beam profiler or a cable qualified for high speed USB 2.0 standard.

Attention

Use only the supplied high speed (USB 2.0) cable. USB 1.1 cables can cause transmission errors and improper instrument operation!

Please make sure, that the USB cable is connected to a USB 2.0 port or that a used USB HUB provides sufficient power. Some models may not be able to deliver the specified max. current (500mA).

After connecting the instrument to the PC, the operating system loads the appropriate USB drivers for the Beam Profiler instrument.

Once connected, an icon will appear in the task bar indicating that the driver installation is in progress

To verify the correct driver installation, check the presence of the instrument in the Device Manager: From the Start button select Control Panel to Device Manager.

If you cannot see an entry please check the [troubleshooting](#) ¹³⁹ section.

4.3 Start the Application

Click the "Programs" → "Thorlabs" → "Thorlabs Beam Application" entry, or simply click the appropriate icon added to your desktop.

The connected instrument is recognized, automatically connected and shown in the Beam Settings panel:

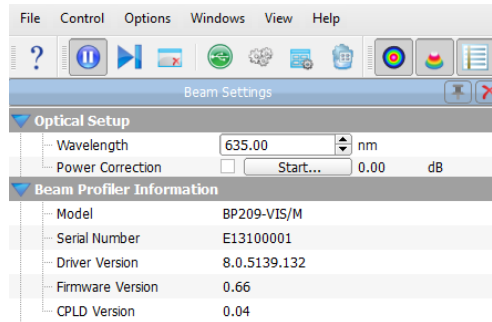

Usually the Beam Software connects automatically to the instrument that has been connected first. If you have connected more than one Beam Profiler and want to use another than the connected device, select to the icon "Device Connection"  and click the desired instrument.

Click on 'Refresh Device List' for an update if you have very recently connected or removed a Beam Profiler instrument from your PC. If an expected instrument is still missing check if the USB driver is properly installed (see chapter [Troubleshooting](#) ¹³⁹).

After selecting a Beam Profiler it will be connected and displayed in the [Beam Settings Panel](#) ²⁶, where all available settings and adjustments to the Beam Profiler can be made.

It is advisable to read the steps described in the chapter [Measurement with the Beam Profiler](#) ⁶³ carefully in order to setup your Beam Profiler device and application properly.

When the Beam Profiler Software is started for the first time, three preselected windows are opened and arranged automatically: Calculation Results, 2D Reconstruction, 3D Profile. Otherwise, the arrangement of the last session (selected windows and their position) will be recovered. See the [Child Windows](#) ³⁹ chapter for a detailed description of each window.

5 Operating Principle

The BP209 Series uses the principle of scanning slits mounted on the perimeter of a rotating drum. This drum is equipped with a position encoder, which delivers exact information on the actual drum position to the analyzing software. Two slit pairs (5 μm slit width for normal measurement and 25 μm slit width for knife-edge measurement) are mounted to the drum.

The slit pairs are oriented orthogonally at angles $+45^\circ$ and -45° with respect to the rotation axis. This scanning axis is tilted at 45° so that the scanning directions of the slits appear as 0° (horizontal) and 90° (vertical), respectively. These scanning directions are marked as X and Y on the front of the instrument.

Using the rotation mount these scanning axes can be tilted to within $\pm 60^\circ$ in order to adapt it to the major and minor axes of an elliptical beam.

Beside the two slit pairs, the drum has an aperture with a neutral density (ND) filter. This aperture is used to take integral power measurements during every revolution.

Note that this power measurement readout is the result of a separate integral beam power measurement (through the ND filter), and not a result of mathematical integration across the scanned beam profile.

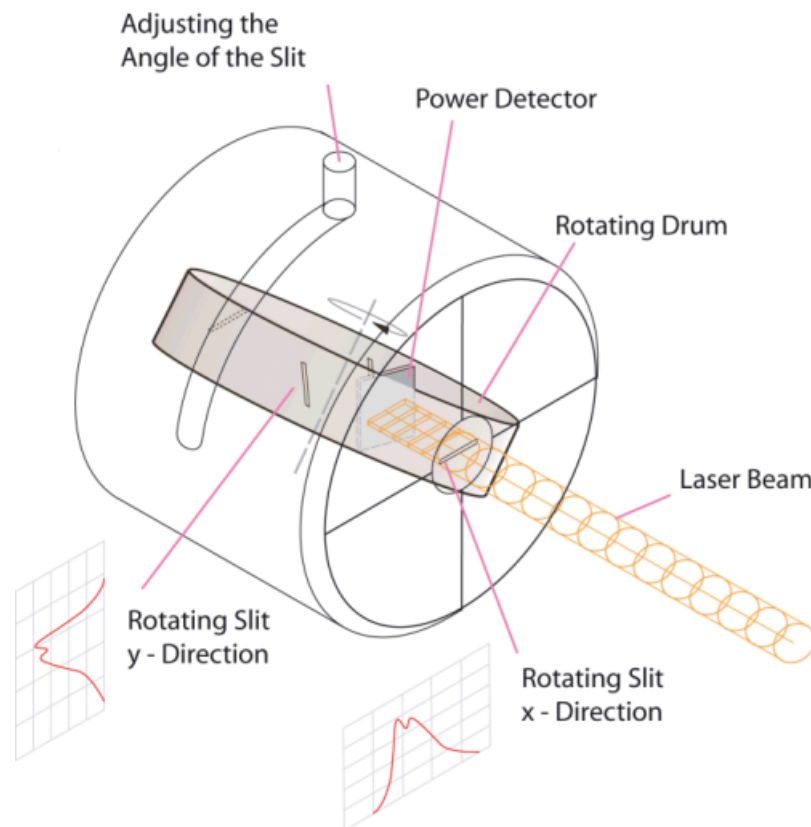

6 The Graphics User Interface (GUI)

In this manual, the Beam Software is described based on a setup using a BP209-VIS/M on the M2MS measurement extension for M² measurements, connected to a PC running with OS Windows® 10.

The main window consists of a menu bar (1), a tool bar (2), a status bar (3) and common frame for displaying several child windows. When starting the application, an additional window is displayed within the main window - the [Beam Settings](#) (4) panel. This panel can be unpinned from the main window and moved to a different display location, e.g., to a second monitor.

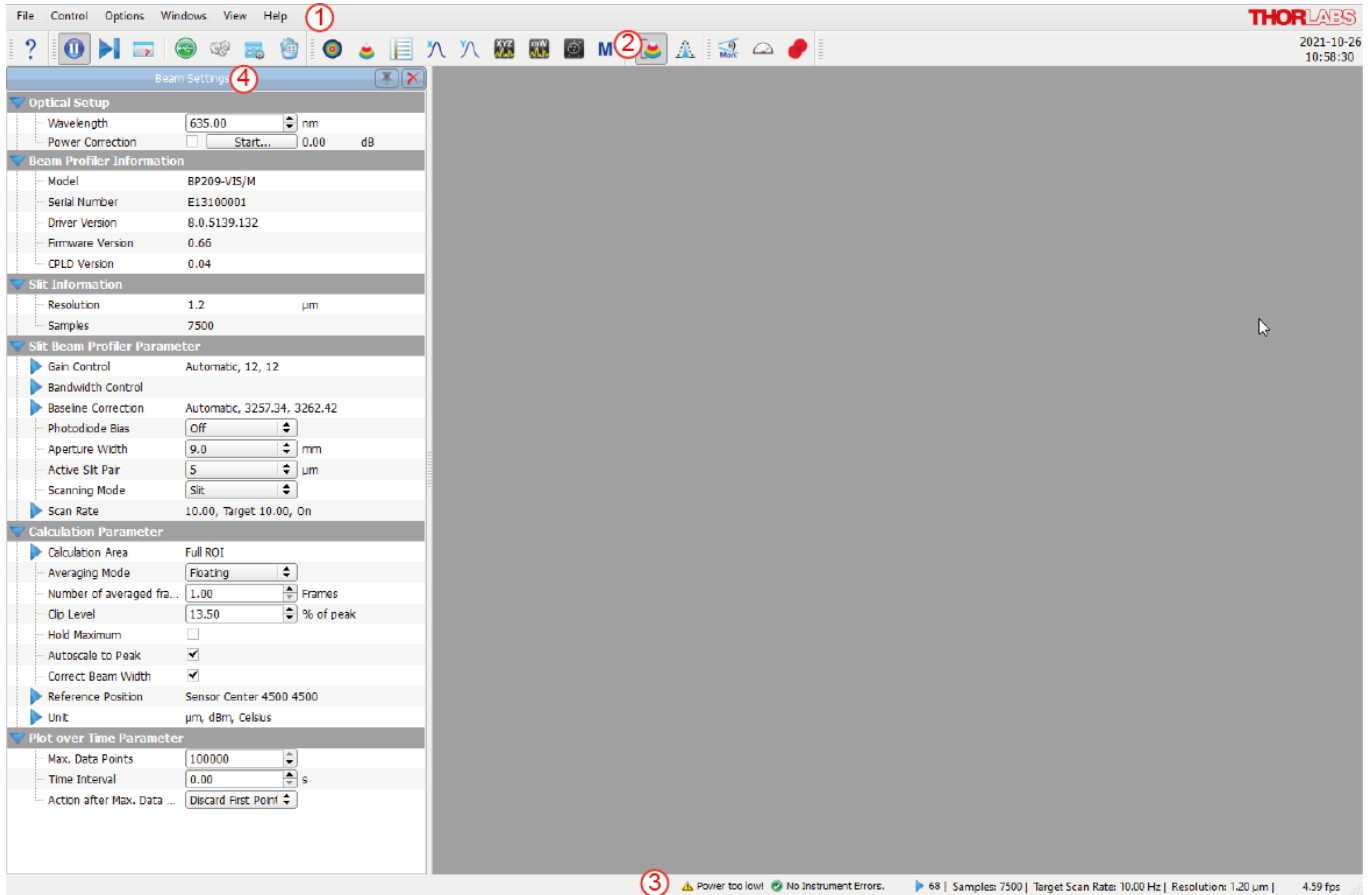

6.1 Menu Bar

All user activities can be done using the menu bar items

File Control Options Windows View Help

6.1.1 File Menu

These menu entries deal with files or printing.

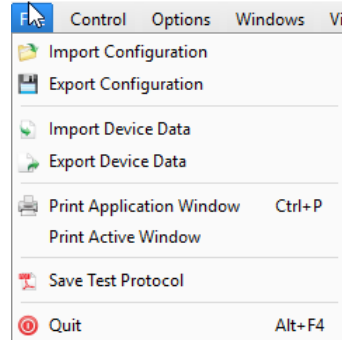

The entries in the first block, **Import** and **Export Configuration**, are related to XML files which contain information about the chosen Beam Profiler device and its settings, file export parameters and application settings. In order to copy the GUI appearance and Beam Profiler settings to another PC you need to save the configuration file, copy it and load it on the target system.

The entries in the second block, **Import** and **Export Device Data**, are used to import and export data originally retrieved from the Beam Profiler in CSV format. Intensity values are saved to a text matrix.

There are 4 columns:

Column	Content
1	X position in μm
2	Intensity at X position
3	Y position in μm
4	Intensity at Y position

A sequential saving is available as well. Details please see in section [Calculation Results](#)⁴⁸.

Print

With the **Print Application Window** a screenshot of the Beam Profiler application is printed.



The **Print Active Window** entry prints the current active child window of the Beam Profiler application. This function gives you the opportunity to print a specific child window.

The **Save Test Protocol** opens a dialog window, where individual data can be entered. Click "Save" and then "Close" to save a test report with the calculation results and the current projection image to the indicated location. If the 3D Profile window is opened, a screenshot of the 3D Profile is also included in the test report.

See some detailed examples for data export in the [Save Measurement Results](#)⁶⁶ chapter.

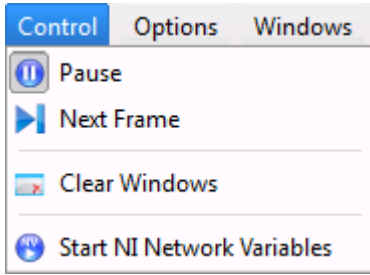
6.1.2 Control Menu



Use the first menu entry to start  and pause  the continuous operation of the Beam Profiler device including retrieving measurement data, performing calculations and displaying graphs and numerical results to the output windows.

"Next Frame" starts a single measurement and returns to pause state.

When the GUI is started or the active Beam Profiler instrument is changed, the application will start continuous operation automatically. Pausing the consecutive operation is advantageous for detailed analysis of a single image. The paused Beam Profiler can be restarted at any time.

The "**Clear Windows**" function resets the content of all windows, including child windows. The window content will be filled with the next measurement result received from the instrument. This function may be useful for a synchronous restart of all plots and time-based measurements.

Note

The measurement of all beam parameters and the accumulation of calculated data is started automatically with the software start. "Clear Windows"  deletes all accumulated data and restarts the measurement.

Start NI Network Variables

This feature is a data interface for handing over the parameters listed below to an external program environment such as LabVIEW.

- Saturation (in %)
- Total Power
- Base Line X and Y
- Peak Value X and Y
- Distance of Peak to Reference Position X and Y
- Distance of Centroid to Reference Position X and Y
- Sigma X and Y
- Beam Width Clip X and Y
- Ellipse Diameter Min and Max
- Gauss Diameter X and Y
- Ellipticity
- User Power Offset
- Serial Number
- Reference Position X and Y

Note

In order to use this command, you need to have installed additional National Instruments® software (Distributed System Manager, NI CVI Runtime Engine).

6.1.3 Options Menu

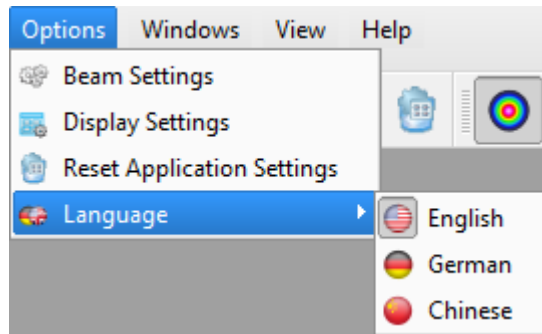

These entries allow changing the device (Beam Profiler) and application (GUI) specific settings and let you choose a language.

Beam Settings

The Beam Settings panel contains all important information about the optical settings, the properties of the active Beam Profiler and a summary of the calculated beam parameters. Please see the detailed description of this panel in the section [Beam Settings](#) ²⁶.

Display Settings Panel

Here, the different styles for **2D Reconstruction** and **3D Profile** are listed for selection.

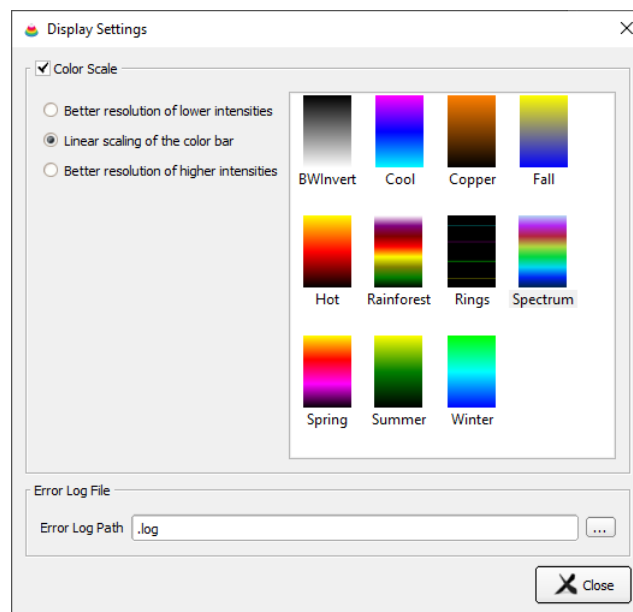

There are 3 different color scale types available:

- Better resolution of lower intensities (Logarithmic Scale)
- Linear scaling of the color bar (Linear Scale)
- Better resolution of higher intensities (Quad Scale)

User-Configured Color Scales

If a certain color scale is required it is possible to create a custom color scale which can be loaded automatically by starting the application. To do so a few things need to be considered.

When starting the software, the application loads valid *.lut files from the folder:

...\\My Documents\\Thorlabs\\Thorlabs Beam\\LUT

A valid *.lut file must fulfill the following criteria:

- Ordinary text file with 9 columns and 256 rows

- Values must be tab-separated
- The first three columns have 256 entries
- The last six columns have only 129
- Each value represents a 8 bit intensity (0- 255) of R(ed), G(reen) and B(lue), respectively.

The first three columns represent the linear scale of a user-made color scale, the next three columns represent the scale for lower intensities (logarithmic scale) and the last three columns the scale for higher intensities (quad scale).

Such a color scale could look like this (The first two rows are not part of the *.lut file; they are shown here only for illustration):

Linear Scale			Logarithmic Scale			Quad Scale		
R	G	B	R	G	B	R	G	B
0	255	0	0	255	0	0	255	0
1	255	0	1	255	0	3	255	0
2	255	0	2	255	0	10	255	0
...	
127	255	0	240	255	0	254	255	0
128	255	0	255	255	0	255	255	0
129	255	0						
...						
254	255	0						
255	255	0						

"..." stands for the intermediary values.



Reset Application Settings to Defaults

This button resets all BEAM application settings to defaults:

Application Setting	Default Value	Explanation
Gain Control	Automatic	Gain is set to automatic.
Bandwidth Control	125 kHz	Instrument set to continuous data acquisition.
Baseline Correction	Automatic	The ADC output signal that is caused by environmental and stray light is compensated.
Aperture Width	9.0 mm	Full Aperture Width is used for calculations.
Active Slit Pair	5 μ m	Slit Pair that is used for measurement
Scanning Mode	Slit	Normal mode, in contrast to Knife Edge Mode
Target Scan Rate	10 Hz	Scan Rate set value.
Scan Rate Correction	Enabled	Enabling Scan Rate Correction, a control loop will maintain the scan rate close to the target value.
Calculation Area Preset	Auto Rectangle	Software determines a rectangular area in which the power level is above the clip level.
Calculation Area Clip Level	1.0 %	For defining the Calculation Area in automatic mode, the lower intensities limit is set to 1% of the peak intensity to clip noise.
Averaging Mode	None	No averaging
Clip Level	13.50 %	The clip level for calculating the ellipse and beam width is set to 13.5% of the difference between the baseline and the peak intensity.
Hold Maximum	Disabled	After reaching the max. number of data to be plotted, with the next data acquisition the first data set will be discarded and the the most recent set will be added.
Autoscale to Peak	Enabled	The diagrams that show intensities, are scaled to the peak intensity.
Correct Beam Width	Enabled	Measurements results are beam-width corrected.
Reference Position	Sensor Center	Reference position is set to the aperture center. Centroid and peak positions are calculated relative to the reference position.
Power Unit	mW	All power units are displayed in mW.
Plot Method	Latest Data	After reaching the max. number of data to be plotted, with the next data acquisition the first data set will be discarded and the the most recent set will be added.
Plot Interval	Every Meas.	For every measurement, the data are plotted
Max. Data Points	100000	The maximum number of data to be plotted
Velocity	200 mm/s	Translation speed of the stage

Language

The language of the application can be selected.

6.1.4 Windows Menu

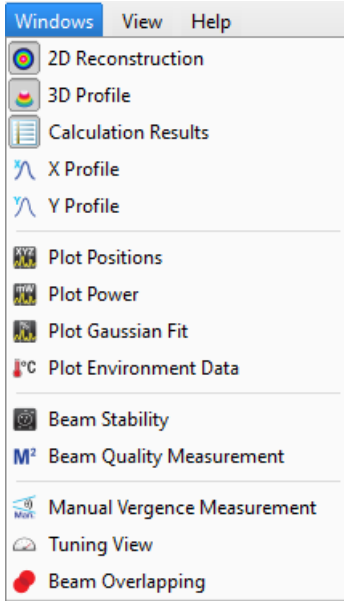

When the GUI is started the first time, the Default Workspace is opened. To close and open the windows, toggle the corresponding entry in the windows menu or via the [Tool Bar](#) .

An open child window can also be closed by clicking the  in the upper right corner of the child window.

6.1.5 View Menu

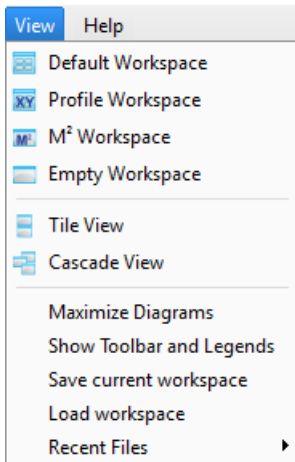

From this menu entry, a number of pre-configured child window arrangements ("workspaces") can be quickly selected:

- Default: Settings panel, Numeric results, 2D reconstruction, 3D profile
- Profile: 2D reconstruction, 3D profile, numeric results, X and Y profiles
- M²: Beam Quality Measurement, X and Y profiles
- Empty workspace

Further, the active child windows can be arranged, tiled, and cascaded.

"**Maximize Diagrams**" turns off the side and top toolbars in all child windows simultaneously, "**Show Toolbar and Legends**" turns them on again.

"**Save Current / Load Workspace**" saves your Beam Software GUI appearance to a ini-file that can be loaded at any time.

"**Recent Files**" lists recently used workspace files so that you can quickly load often used workspaces.

6.1.6 Help Menu

Click "Contents", the first entry within the help menu, or press the "F1" key on the keyboard to open the online help file, which contains all information included in this manual.

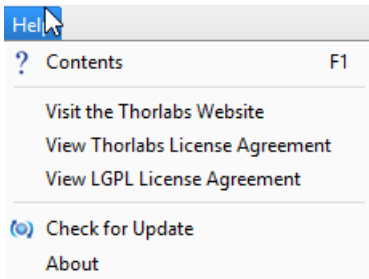

With a click on the link *Visit the Thorlabs Website* this website is opened in the browser window.

View Thorlabs (LGPL) License Agreement will open the license files of the installer package.

Check for Update searches for available software updates.

About Thorlabs displays device information and software versions details:

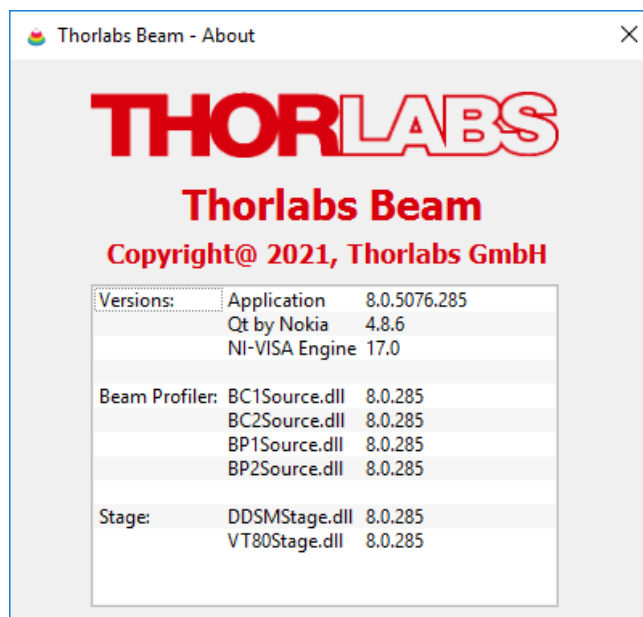

If you have trouble with the software, please submit the version of the application to Thorlabs. This can help to resolve your problem.























6.2 Tool Bar

For the most important menu entries there are also symbols provided in the tool bar.



Clicking on a toolbar symbol will have the same effect as clicking on the original menu entry. When moving the mouse over the icons, a tool tip will be displayed.

In the list below the toolbar icons are explained.

-  Open the online help file
-  [Pause and Start the continuous device operation](#) ^[18]
-  [Take a single measurement](#) ^[18]
-  [Clear the content of each window](#) ^[18]
-  Open the [Device Connection](#) ^[14] dialog
-  Restore [Beam Settings](#) ^[26] panel (if unpinned or closed)
-  Open the [Display Settings](#) ^[19] panel
-  [Reset Application Settings to defaults](#) ^[21]
-  Open child window [2D Reconstruction](#) ^[40]
-  Open child window [3D Profile](#) ^[42]
-  Open child window [Calculation Results](#) ^[45]
-  Open child window [X Profile](#) ^[43]
-  Open child window [Y Profile](#) ^[43]
-  Open child window [Plot Position](#) ^[56]
-  Open child window [Plot Power](#) ^[57]
-  Open child window [Beam Stability](#) ^[61]
-  Open child window [Beam Quality \(M²\)](#) ^[87]
-  Toggle auto scale to peak on/off
-  Toggle Hold Maximum on/off
-  Open child window [Manual Vergence Measurement](#) ^[49]
-  Open child window [Tuning View](#) ^[51]
-  Open child window [Beam Overlapping](#) ^[53]

6.3 Status Bar

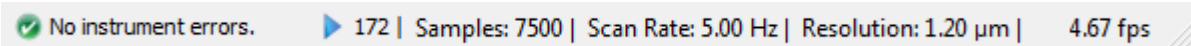

The status bar displays important status information about the Slit Beam Profiler concerning

- Errors and warnings, see chapter [Warnings and Errors](#)¹⁴⁰.
- Plot Data Point Status, see section [Plots](#)⁵⁵.
- Instrument settings like taken samples, scan rate and target resolution.
- Current refresh rate of the application in frames per seconds (fps).

6.4 Save Settings





The actual settings of the GUI including configurations of the graphical displays and the instrument setup are automatically saved when exiting the program. When starting the Beam Software again, the most recent settings are automatically loaded.

Exception: Gain and bandwidth are set to "Auto", automatic baseline correction disabled.

Note

The stop state of the previous measurement will be ignored at a new start of the Beam Software because it always starts in continuous mode.

6.5 Beam Settings

The **Beam Settings** panel is a very convenient visualization of all important information and settings that can be made to the instrument and to the calculation parameters. For a better visibility, the Beam Settings topics are arranged in expandable group boxes that allow to show or hide topics. Further, the Beam Settings panel is the only child window that can be detached: When starting the application, this panel arranged by default within the main window. Drag and drop it to any convenient location within or outside the GUI main window, e.g., to a second PC monitor. When detached, the **Pin** icon in the upper right corner changes from  to . Click to this icon to bring the panel back into the GUI frame. The panel view can be customized easily by expanding  or hiding  topics.

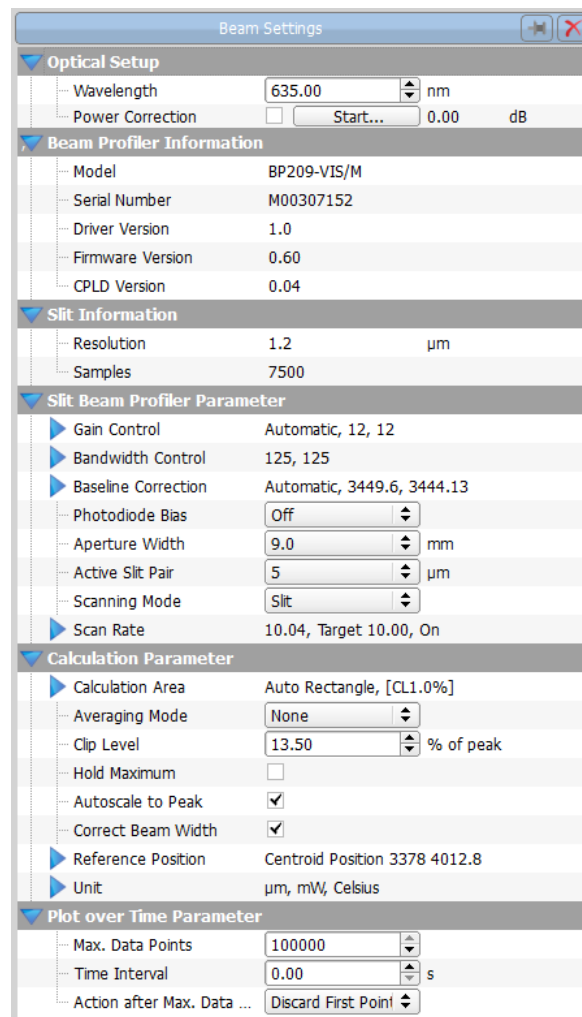

Beam Settings BP209x

Please read this section carefully and follow the setup instructions in order to maximize the accuracy of your measurements.

6.5.1 Optical Setup

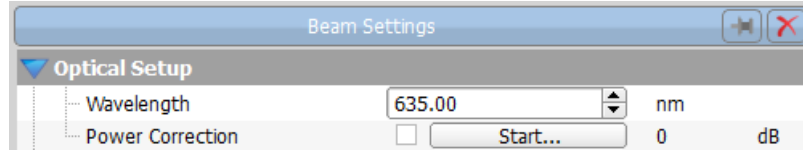

This part of the **Beam Settings** panel

- sets the [operating wavelength](#)²⁷
- executes a [power correction](#)²⁸

Initial Settings

When this Beam Profiler is connected for the first time, the following default values are set:

Parameter	Default Value
Wavelength	635 nm (BP209-VIS(/M)) 500 nm (BP209IR1(/M)) 900 nm (BP209-IR2(/M))
Power Correction	off

6.5.1.1 Wavelength

Enter the operating wavelength in nm as a precondition for proper measurement of the Total Power. The power calculation is based on the entered wavelength and the typical responsivity curve of the photo diode stored in the Beam Profiler instrument. See [Typical Photodiode Response Curve](#)¹⁴⁸. The correct wavelength is important for accurate Beam Quality (M^2) results as well.



The range of allowed wavelength values is limited to specified range of the recognized Beam Profiler.

6.5.1.2 Power Correction

The Power Correction allows the user to set the total beam power measured by the Beam Profiler to the power level measured by a reference power meter.

Preconditions:

Be sure to have set the operating wavelength accurately.



Click the 'Start' button - the Power Correction Dialog appears.

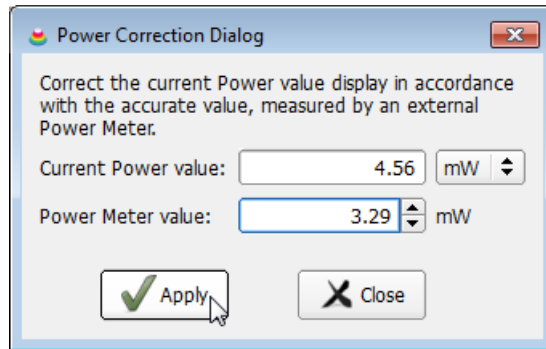

The 'Current power value' is the actual power measured by the Beam Profiler. Enter the power meter reading into the 'Power meter value' control. Click 'Apply' to enable corrections, then click 'Close' to leave the panel.

The difference between the entered power value and the actually measured by the instrument power will be displayed as an offset, here -0.161994 dB.



This offset (in dB) is stored in the Beam Profiler and is read out and activated automatically each time after connecting this instrument.

Note

The user calibrated power reading is correct only at the actual wavelength. If the wavelength changes, the power correction needs to be carried out again.

After executing the Power Correction it is activated automatically, which is indicated by the check mark.

The activation state is saved in the software. When restarting the software using the same instrument, the offset is recognized, read out and the same activation state (active / inactive) as in the previous software session will be restored.

If the power correction is not active, the attempt to activate it lets the software check the Beam Profiler for a saved offset. If no saved offset is found, the Power Correction dialog opens and asks for a power meter value. If an offset is recognized, it will be applied immediately. For this reason it is recommended that a power correction is to be performed if the environment of the instrument was changed.

6.5.2 Beam Profiler Information

Beam Profiler Information		
Model	BP209-VIS/M	
Serial Number	M00307152	
Driver Version	1.0	
Firmware Version	0.60	
CPLD Version	0.04	
Slit Information		
Resolution	1.2	[μm]
Samples	7500	

Beam Profiler model, serial number, driver, firmware and CPLD versions are read out from the BP209 Series instrument and cannot be changed. Beside general information, important sensor information is stated.

Resolution

is the achievable resolution for the given scan rate and [aperture width](#)³². It's limited by the sampling rate of the AD converter.

If scanning the entire aperture (9mm), the resolution will be affected only for scan rates $> 19 \text{ s}^{-1}$. The range of resolution for these higher scan rates is $1.20 \mu\text{m}$ to $1.24 \mu\text{m}$.

A higher resolution can be achieved by limiting the scanned aperture to 10% of the entire width ($\varnothing 0.9 \text{ mm}$), see [Miscellaneous](#)³². With this option, the resolution depends strongly on the scan rate and ranges from $0.124 \mu\text{m}$ (scan rate 2 s^{-1}) to $1.24 \mu\text{m}$ (scan rate 20 s^{-1}).

Samples

is the number of measurement values used for beam profile calculation. It is limited by the AD converter sampling rate and varies, depending on the selected [aperture width](#)³² and scan rate.

6.5.3 Slit Beam Profiler Parameter

This section contains a number of important Beam Profiler parameters that are accessible by the user. Please become familiar with the meaning of these controls in order to prevent improper adjustments which may lead to erroneous measurement results. All visible controls are explained below.

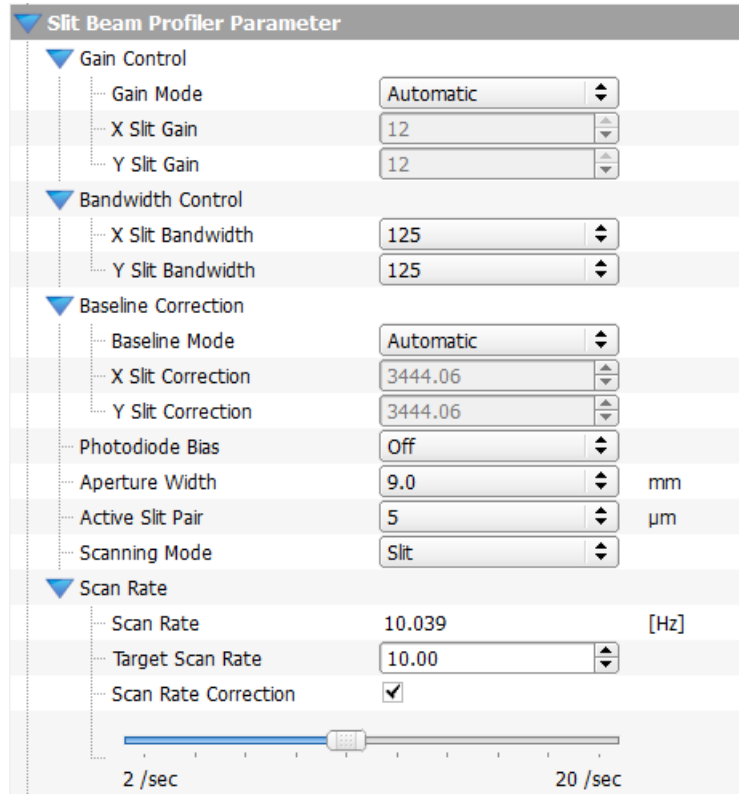

Details on the individual parameters are explained in the subsequent sections.

Initial Settings

When this Beam Profiler is connected for the first time, the following default parameters are set:

Parameter	Default Value
Scan Rate	10.0 s ⁻¹
Scan Rate Correction	enabled
PD Bias	off ¹⁾
Aperture Width	full width (9 mm)
Active Slit Pair	5 μm
Scanning Method	Slit Scanning
Auto Gain Index	ON
Bandwidth Slit X	125 kHz
Bandwidth Slit Y	125 kHz
Auto Baseline Correction	on

¹⁾ Switchable photodiode bias is not available for BP209-IR2 model.

6.5.3.1 Gain, Bandwidth and Baseline

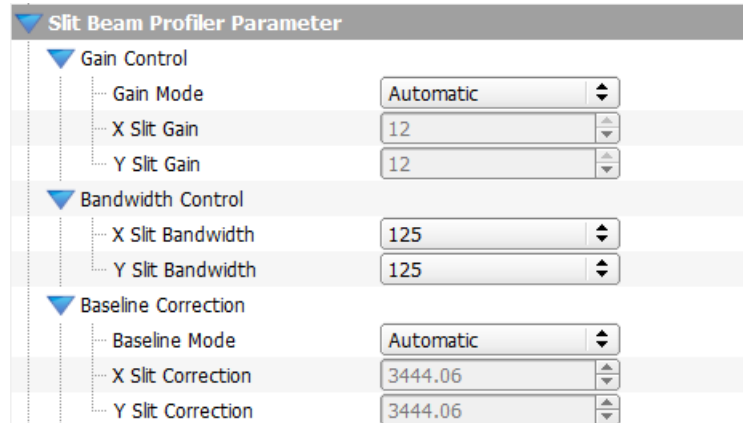

Gain and Bandwidth are the parameters of the photo current amplifier. Higher bandwidth is recommended to achieve high resolution when measuring small beam diameters. The bandwidth can be set between 16 kHz and 660 kHz, if the full 9.0 mm aperture width is used, and between 16 kHz and 1000 kHz, if the 0.9 mm aperture is used for measurement.

Each time the software is started, gain is set to Auto, bandwidth to 125 kHz and the Baseline Correction is set to Auto. This is the preferred setting for most measurements. However, in some cases, e.g. measurement of [pulsed lasers](#)^[72], it is recommended that these settings be changed manually.

Baseline Correction

The baseline is the ADC output signal that originates from the photo detector's dark current, the output offset and noise of the ADC. It results in a beam profile shift away from the zero line. Enabling the Auto Baseline Correction, this influence is compensated. It is recommended to have it enabled.

6.5.3.2 Scan Rate

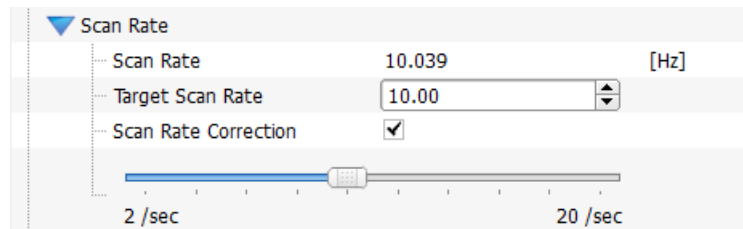

Scan Rate

Here, the actual scan rate (drum rotation speed) is displayed

Target Scan Rate

This is the rotation speed of the drum in s^{-1} . The entered value is transformed into a control voltage for the drum drive. Values between 2 and 20 s^{-1} can be entered either numerically or by clicking to the arrows attached to the numeric box or by shifting the slider.

Scan Rate Correction

The actual rotation speed may differ from the entered target scan rate due to the drum drive warming up: The longer the unit operates, the faster the drive runs at the same control voltage. Enabling Scan Rate Correction, a control loop will maintain the scan rate close to the target value.

6.5.3.3 Miscellaneous

Photodiode Bias	Off	
Aperture Width	9.0	mm
Active Slit Pair	5	μm
Scanning Mode	Slit	

Photodiode Bias

Biassing a photo diode decreases its rise time. Set Bias to **On** for measurement of small beam diameters and M^2 measurement.

Note

Biassing is possible only for BP209-VIS and BP209IR1 models.

Aperture Width

The maximum aperture diameter is 9 mm. The resolution can be improved if using only 10% of the aperture for beam analysis, particularly in case of small beam diameters or when using the [knife edge mode](#)^[74].

Active Slit Pair

The BP209 Series comes with two pairs of slits. The identification of the slit pairs is given by their location on the perimeter of the drum, and only the active slit pair is used for beam analysis.

With **5 μm** slit pair, beam diameters down to 20 μm can be measured using the standard Slit Scanning method. If the beam diameter is less than that, the Knife Edge Mode must be used instead, in combination with the **25 μm** slit pair. This is explained in detail in the [Knife Edge Mode section](#)^[74].

Scanning Mode

Select **Slit** Scanning for beam diameters > 20 μm (with 5 μm active slit pair) and **Knife Edge** for beam diameters < 20 μm (with 25 μm active slit pair).

6.5.4 Calculation Parameter

This section in the [Beam Settings](#)^[26] is used to set parameters for beam profile calculation. Shown below is the view of the Calculation Parameter section at the first start of the Beam Software or after pressing the "[Reset Application Settings to Defaults](#)"^[21] button  in the toolbar:

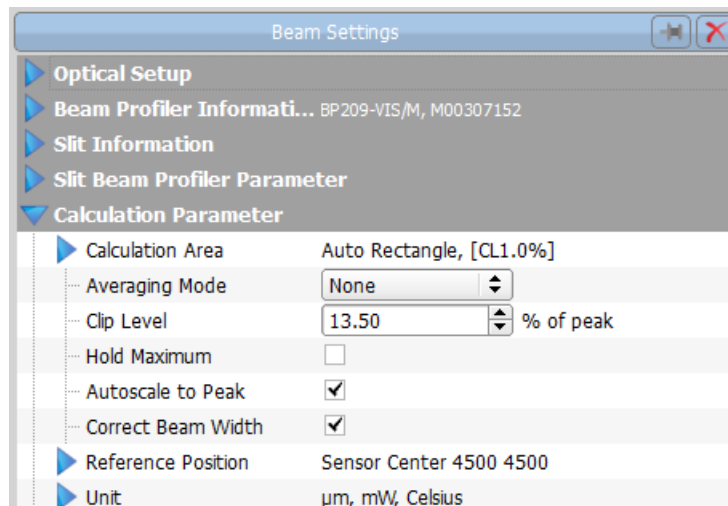

6.5.4.1 Calculation Area

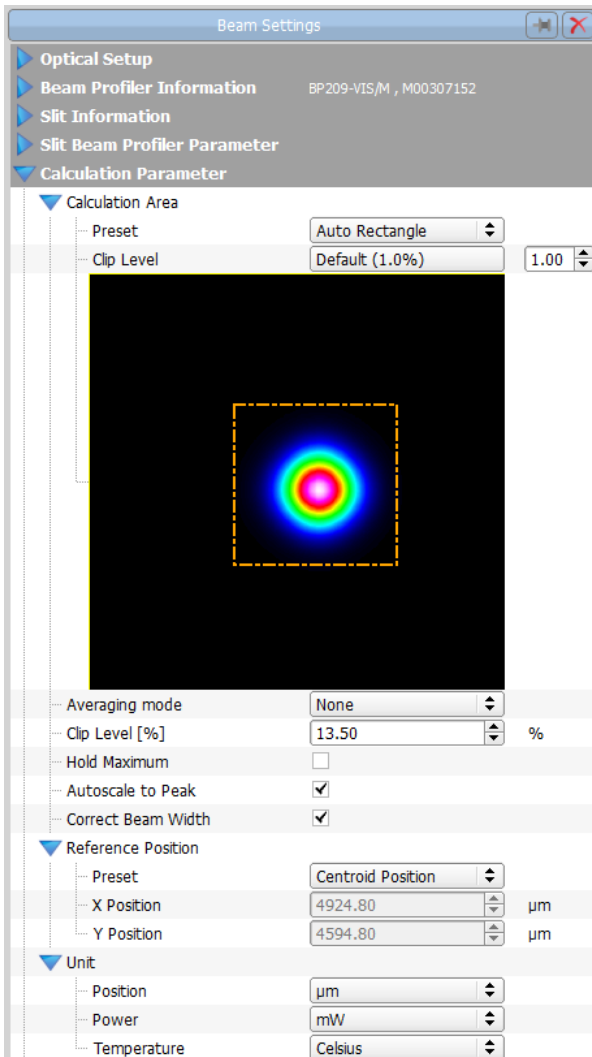

The Calculation Area defines a specific area within the full Region of Interest (ROI). Whereas the ROI is the entire image area that is retrieved from the BP209 Series and displayed, the Calculation Area can be equal to or smaller than the ROI and defines the reconstruction area that is used for all numerical calculations.

Limiting the calculation area is advantageous particularly for

- Selecting and analyzing only a single beam spot among multiple beams
- Rejecting ambient or stray light
- Reducing measurement noise

Three presets are provided to choose a Calculation Area:

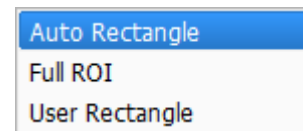

Auto Rectangle:

The software will analyze every image from the BP209 Series automatically and determine the area in which a measurable amount of power is present. Areas with a power level lower than the [clip level](#)³⁴ will be excluded from further calculations.

Full ROI:

The entire image area defined by the ROI is involved in beam calculations.

User Rectangle:

A rectangular area, set by user input is defined as Calculation Area. Enter pixel values which describe the Calculation Area position and size or simply drag a rectangle into the 2D Reconstruction window.

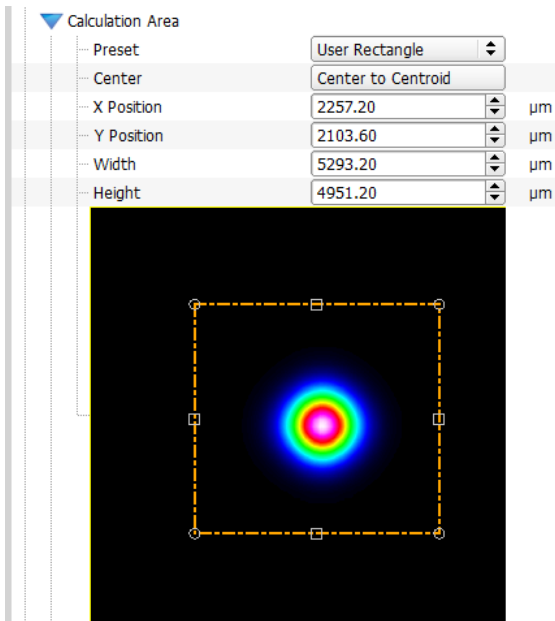

When "User Rectangle" is selected, please enter size and position of the Calculation Area numerically or drag and drop the borders of the user rectangle. All values are in μm , and the point of origin is situated in the upper left corner of the entire sensor area. X (Y) Positions describe the position of the left (upper) border of the user rectangle (ellipse).

The Calculation Area can also be set and visualized within the [2D Reconstruction](#)⁴⁰ window. See the appropriate chapter for details.

Clip Level of the Calculation Area

If the calculation area is detected automatically (**Auto Rectangle**), the borders of the Calculation Area in all four directions are defined by the calculation area clip level.

The border in one direction is set when all pixel values fall (seen from the peak) below the Clip Level. Decreasing the Clip Level increases the Calculation Area which in return increases for example the 4σ diameters, but also increases the noise. For a steep beam profile, 1.0% is an optimal clip level value. If the beam profile is rather flat, it might be advantageous to lower the clip level.

The clip level is set by default to 1 % and can be set between 0.01 and 13.5 %. In order to quickly return to the recommended 1.0% clip level, just click to the box *Default (1.0%)*.



Note The "Clip Level of Calculation Area" is different from the [Clip Level](#)³⁵ used for beam profile calculations!

Attention

The calculation area must not cut off lower intensity parts of the beam profile. This may cause inaccurate calculation results!

6.5.4.2 Averaging Mode

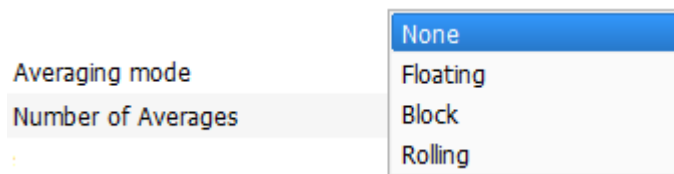

Three modes are available - floating, block and rolling.

When using an averaging mode, please also define the number of averaged frames, which can be set from 1 to 100.

In **Floating mode**, the average is calculated from the weighted previous average and the recent frame. Example: Floating average is made for 10 frames. The previous average value is multiplied by 9, then the recent frame value is added and the sum is divided by 10, which gives the new average value.

In **Block mode**, the indicated number of frames is accumulated, after acquisition the average is calculated and displayed. This is the slowest mode.

In **Rolling mode**, the averaging is done over the indicated most recent number of frames. Example: Rolling average is made for 10 frames. The most recent 10 frames are averaged and displayed, the value is updated with each new frame.

Setting the frames to numbers higher than 1 enables noise reduction.

This option is helpful for unstable light sources with fluctuating intensity or beam shape, or if the update rate on the screen is too high for easy data readout. Also use this option to suppress Beam Profiler noise in case of low intensity.

6.5.4.3 Clip Level

In contrast to the [Calculation Area Clip Level](#)³⁴, the **Clip Level** parameter is used to determine the beam width. It defines a relative intensity level between dark level (0%) and peak level (100%) of the measured beam profile at which the beam width is determined. The ISO11146 Standard recommends a default value of $1/e^2 = 13.5\%$ of the peak intensity. Other values from 5% to 95% can be set by entering manually.

Click on *Default (1/e²)* to set the default Clip Level of 13.5%. See Appendix [Application Note](#)¹⁴³ for details.

6.5.4.4 Hold Maximum

The **Hold Maximum** feature is recommended for pulsed laser sources. In all subsequent scans for each pixel only the maximum values are stored, displayed and used for calculation.

6.5.4.5 Autoscale to Peak

Enable the "**Autoscale to Peak**" check box to scale the X and Y profiles to their peak intensities. Disabling will scale the X and Y profiles to the value of AD saturation.

6.5.4.6 Correct Beam Width

The **Correct Beam Width** option should be activated by default.

It corrects for the measurement error due to the finite slit width for all methods (13.5% clip level with and without Gaussian fit). Since this convolution error is systematic it can be calculated and eliminated. This feature increases the measurement accuracy, particularly when measuring narrow beams.

6.5.4.7 Reference Position

The reference position influences the calculation results. Peak and Centroid positions refer to the reference position. By default, the reference position is set to the sensor center. In the 2D Reconstruction window it is displayed as a grey crosshair.

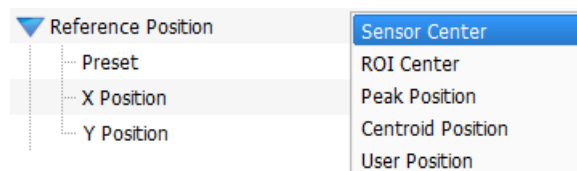

The Reference Position can be set to predefined positions (see above) or to a user defined position. The X and Y coordinates of a user defined position are to be entered numerically or set in the [2D Reconstruction](#)⁴¹ (Reference Position Editor):

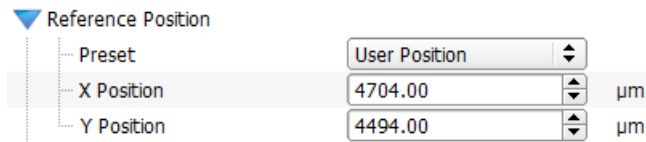

6.5.4.8 Unit



The measurement units that are displayed in the Beam Software can be selected in the **Unit** topic.

Position units: **μm.**

Total Power units: **mW or dBm.**

Temperature: **°C, °F or K.**

(Temperature is measured by an external Thorlabs TSP01 Environmental Sensor, connected via USB (not included).)

The following table gives an overview on all available units:

Unit	Description
μm	Location, width or distance in μm. The origin of the coordinate system (X=0, Y=0) is the sensor center, not the image center! Positive X values go to the right, positive Y values to the top of the image. Value range: - 4500 to + 4500 μm.
mW	The Total Power of the beam is calculated from measurement of the total photo diode current, using its typical wavelength dependent responsivity and the power correction value.
dBm	The Total Power translated from mW into dBm: $10 * \log (P[\text{mW}])$. 0 dBm = 1 mW
%	Relative level between 0 and 100%
deg	Angle in degree with respect to the X axis, range -90 to +90 deg

6.5.5 Plot Over Time Parameter

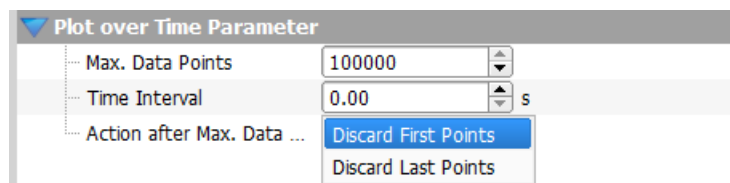

The Beam Software allows to show different plots of beam measurements:

[Plot Positions](#) ⁵⁶

[Plot Power](#) ⁵⁷

[Plot Diameters](#) ⁵⁸

[Plot Gaussian Fit](#) ⁵⁸

[Plot Environment Data](#) ⁶⁰
[Beam Stability](#) ⁶¹

The section **Plot Over Time Parameter** is used to configure these plots:

- The maximum number N of data points in the plots can be defined (N=1 to 100000).
- The time interval between two data points can be selected (between 0 = every measurement to 1000 s; default = every measurement).
- Specify the action performed after the maximum number N of recorded data points is reached:
 - "Discard First Points" means the 1st data set is discarded and the most recent data point will be added to the plot. In other words, after reaching the maximum number N of plotted data points, the plot continues and displays the most recent N data points.
 - "Discard Last Points" means that all data points beyond N will be discarded. In other words, after reaching the maximum number N of data points, the plot stops.

6.5.6 Translation Stage Control

If a translation stage is detected as is the case when a M2MS measurement extension is connected and powered, the topics "Translation Stage Control" and "M² set" appear as the last two topics of the Beam Settings panel. The description in this section assumes a Thorlabs DDS100 Linear Translation Stage, as it is used in the [M2MS Extension Set](#) ⁷⁹.

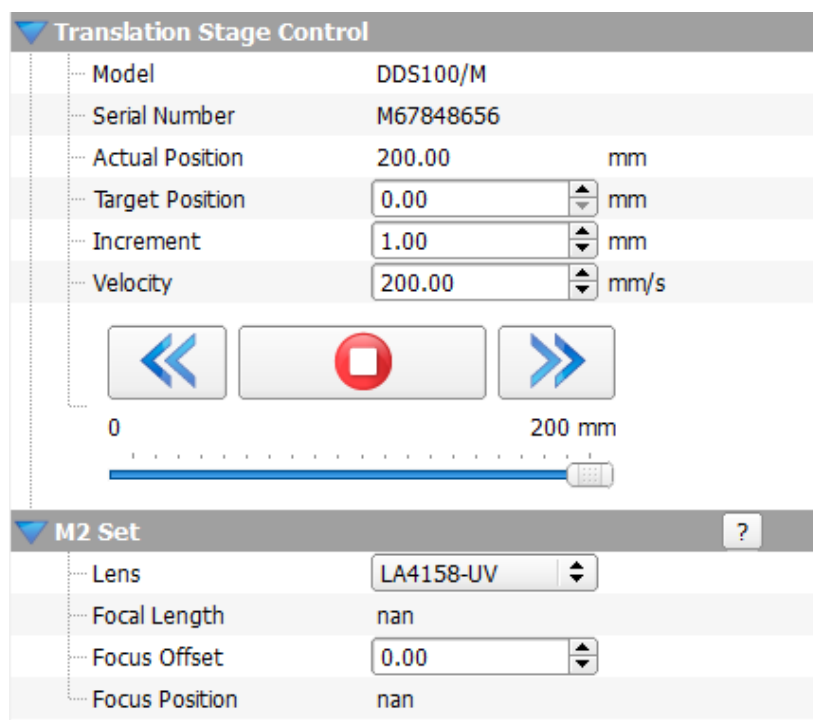

This panel allows the user to manually control the translation stage. This is useful for a coarse setup of the M² or [Divergence Measurement](#) ¹¹⁵.

Actual Position displays the present stage position.

Target Position: Enter a value between 0 and 200 mm, press "Enter" on your keyboard, and the stage will travel with the set **Velocity** (see below) to the new position.

Note

The total displacement reaches from 0 to 200 mm, although the stage translation path is only 100 mm. This results from the mechanical design of the [M2MS](#)⁷⁹ M² Meter Set.

Increment: Enter the increment for moving the stage stepwise.

Velocity: This is the speed of the stage when traveling between two positions (e.g., between the actual and the target position).



Pressing these buttons moves the stage backward / forward for one step, equal to the **Increment**.



Pressing this button interrupts the continuous stage travel to a target position.

The slider bar on the bottom of the panel has two functions - it shows the stage position, and the slider can be moved with the mouse in order to start a stage travel.

M2 Set

The panel "M2 Set" allows to set the lens parameters for the M2MS extension such that the beam waist before the lens can be calculated. The Lens Type and Focus Offset are chosen by the user. The software calculates the focal length and beam waist based on the provided information, including the wavelength as set above under [Optical Setup](#)²⁷.

The focus position is then determined based on internal M2MS parameters, the type of beam profiler, the focus offset and the determined focal length.

6.6 Child Windows

When starting the application first time, three child windows are opened and arranged automatically:

- [2D Reconstruction](#) ⁴⁰
- [3D Profile](#) ⁴²
- [Calculation Results](#) ⁴⁵

The application also provides other windows:

- [X Profile](#) ⁴³
- [Y Profile](#) ⁴³
- [Plot Positions](#) ⁵⁵
- [Plot Power](#) ⁵⁷
- [Plot Diameters](#) ⁵⁸
- [Plot Gaussian Fit](#) ⁵⁸
- [Plot Environment Data](#) ⁶⁰
- [Beam Stability](#) ⁶¹
- [Beam Quality \(\$M^2\$ \)](#) ⁷⁷
- [Manual Vergence Measurement](#) ⁴⁹
- [Tuning View](#) ⁵¹
- [Beam Overlapping](#) ⁵³

All above windows can be opened and closed by clicking the symbols in the toolbar or by selecting the entries in the menu "Windows". Additional child windows are accessible through the [menu bar](#) ¹⁷.

The appearance of the Thorlabs Beam Software can be arranged according to your requirements and taste. All child windows can be re-sized and flexibly positioned. Here is an example of arranging some child windows:

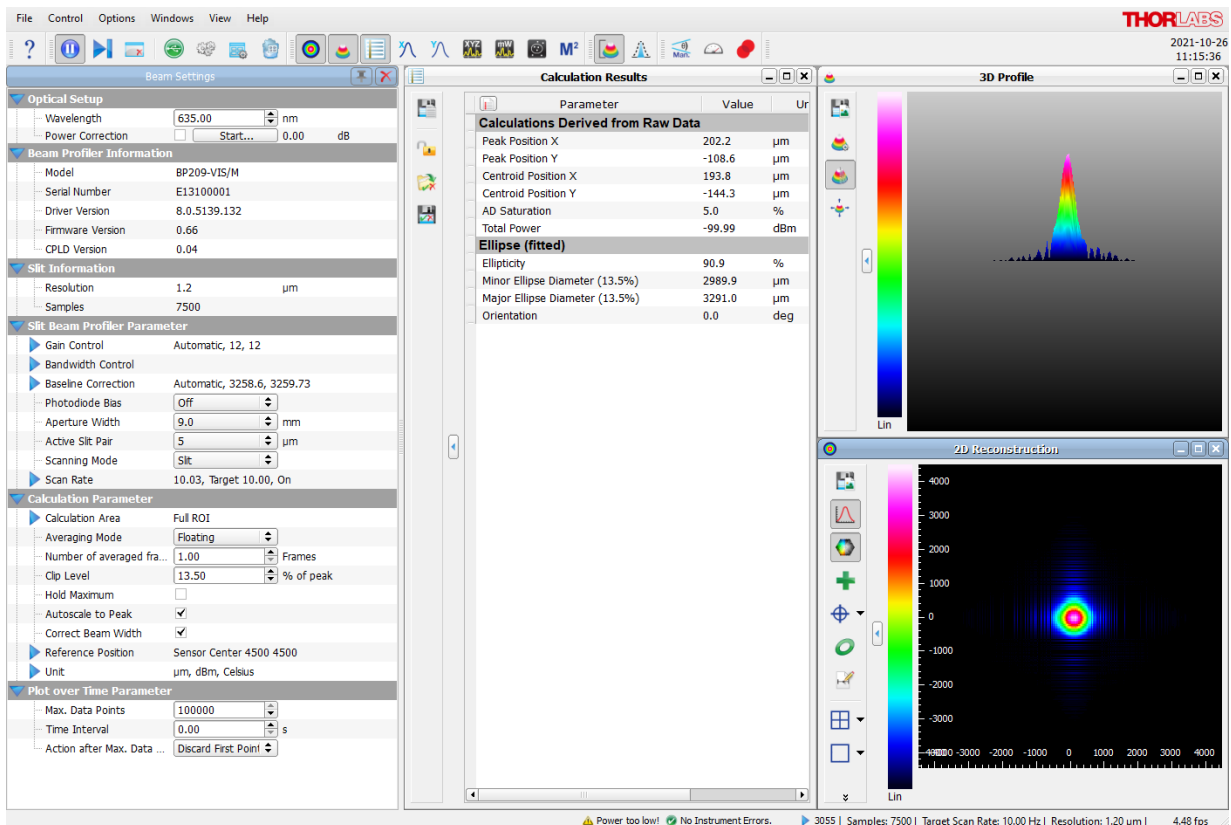

To close a child window deselect the menu entry or the appropriate toolbar symbol or click the close button "X".

Each child window can be moved and resized. If a child window is closed, size and position are stored and recovered when it is reopened.

When the GUI application is closed and reopened, the main panel will have the same child panels open in their former positions. To arrange the windows automatically use the function "Tile View" from the "View" menu.

6.6.1 2D Reconstruction

The 2D Reconstruction graph shows the image from the Beam Profiler indicating the power intensity distribution. This window can be opened and closed via the menu item "2D Reconstruction" in the window menu or via the toggle button  in the toolbar.

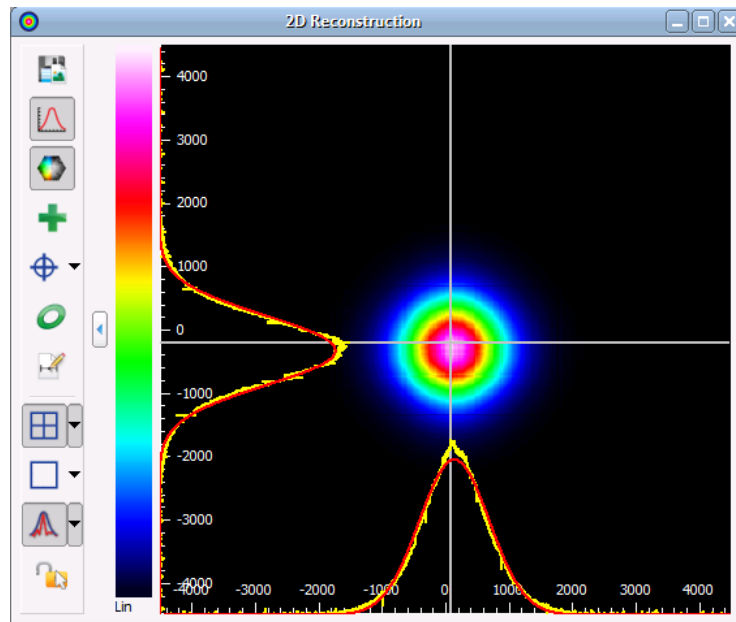











The 2D image is based on a reconstruction since a slit Beam Profiler delivers measurement results of two real cross sections only, the X and the Y profile. The remaining pixel values are calculated by multiplying the normalized cross section values of the respective row and column. An additional bottom clipping is done to limit amplified noise.

Note

Remember, this is only a reconstruction of an assumed Gaussian-like profile, it does not show a completely measured 2D cross section.

On the left side of the 2D Reconstruction window a toolbar is located with the following toggle buttons:

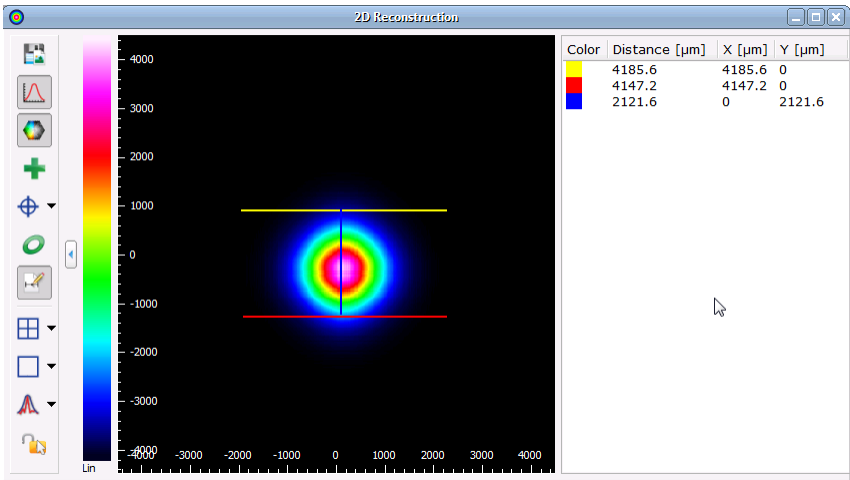
Toolbar Symbol	Associated Action
 Save Diagram or Data	Opens a dialog box to specify the properties of the saved screenshots / data.
 Scale	Show or hides the x and y scale
 Color	Changes the color of the image from gray scale to rainbow colors (see Display Settings ¹⁹).
 Peak	Marks the Peak Position using a green cross
 Centroid	Marks the Beam Centroid using a blue cross within a blue circle
 Ellipse	Displays the approximated Beam Ellipse in yellow color.
 <ul style="list-style-type: none"> • Set Reference Position to Sensor Center • Set Reference Position to Peak Position • Set Reference Position to Centroid Position • Set Reference Position to User Position 	The reference position has influence on the calculation results. The peak and centroid position refer to the reference position. The reference position can either be the center of the sensor, the peak position, the centroid position or a user defined position which can be set with the reference position edit mode or in the Beam Settings ³⁵ .
 <ul style="list-style-type: none"> • Set Calculation Area Automatic • Set Calculation Area to Full Size • Set Calculation Area by User 	The Calculation Area is a subarea of the full ROI. It defines the reconstruction area that is used for all numerical calculations and can be displayed or hidden by toggling the <input type="checkbox"/> button. A drop-down menu allows to make a choice between Automatic or Full Size; additionally it can be defined by the user. Detailed explanations please see in section Beam Settings ³³ .
 Insert X and Y Profiles	Draws X and Y Profiles into the 2D graph displaying the power distribution within a horizontal and a vertical cross section. The positions of these X and Y cross sections are fixed to the sensor center.
 Distance Editor	The distance measurement editor opens a table beside the projection image. When drawing lines into the projection image, the distance is inserted into the table. A maximum of 10 distances can be drawn. Remove a distance entry by selecting the entry and pressing the "DEL" key or select the entry and choose the "Delete Distance" entry from the context menu. <div style="text-align: center; margin-top: 10px;">  </div>

If the window height is smaller than the full toolbar, the lower symbols are packed into a context menu which is accessible via a arrow button on the bottom of the toolbar.

6.6.2 3D Profile

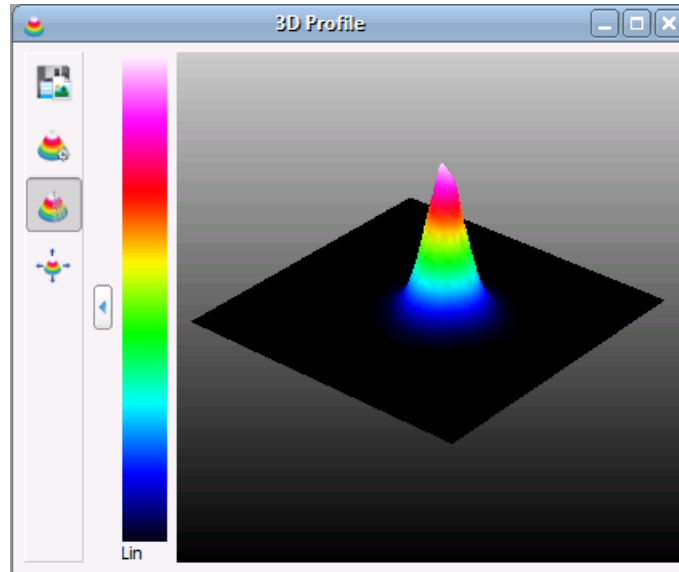

The 3D Profile illustrates the power density distribution of the measured optical beam. Whereas the beam's cross-section is parallel with the X-Y-plane, the relative power intensity is shown in the Z direction (Pseudo 3D). This window can be opened and closed via the menu item "3D Profile" in the window menu or via the toggle button  in the toolbar.





The 3D profile can be moved, rotated and zoomed with the mouse:

Rotate: Press right mouse button and move mouse

Move: Press left mouse button and move mouse

Zoom: Scroll mouse wheel

The following table summarizes the toolbar symbols available within the 3D Profile window and its appropriate action.

Toolbar Icon	Associated Action
	Opens a dialog box to specify the properties of the saved screenshots / diagrams.
	Opens the 3D Profile Settings dialog box.
	Toggles the appearance of the profile between solid to wired (default).
	Resets the manipulations of translation, rotation and zoom to the default view.

Position, size and rotation angle are also displayed within the 3D Profile Settings dialog box. Numerical values can be set to define the 3D Profile appearance:

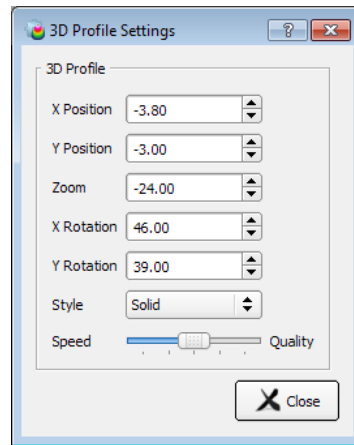

Note

- If the slider "Speed - Quality" is in the far right position, the 3D image is displayed with highest quality.
- The higher the 3D image quality is set, the more system resources are used. Depending on the system capabilities, the software may slow down.

6.6.3 X and Y Profiles

Both windows can be opened and closed via the menu item "X Profiles" or "Y Profiles" in the window menu or clicking on the appropriate toolbar symbols.

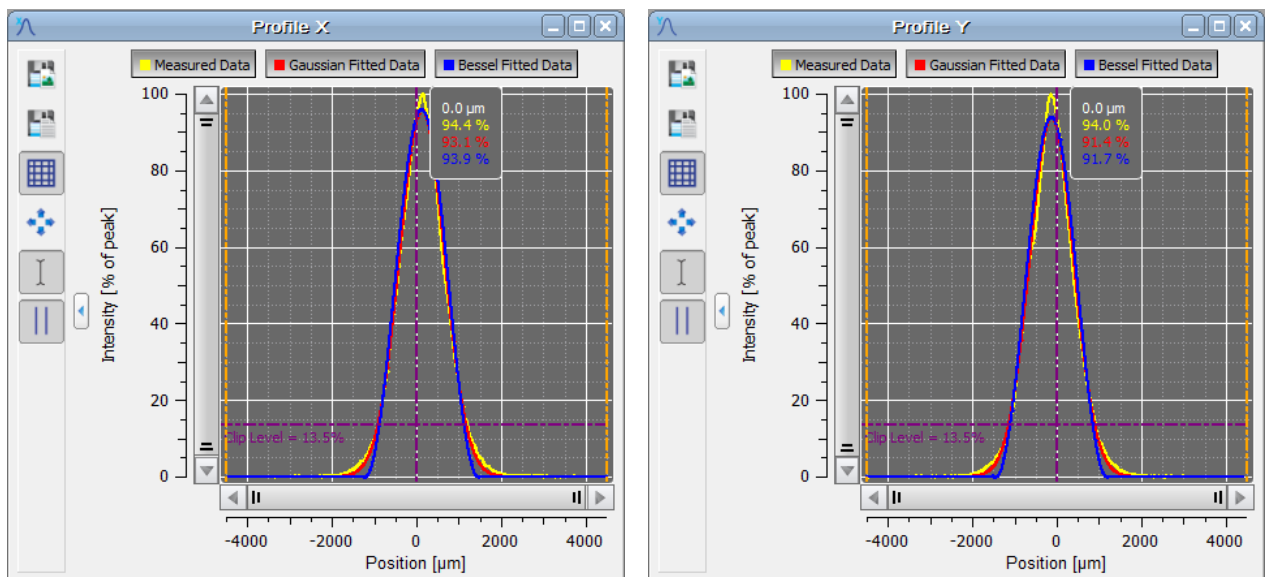

X and Y profiles display the intensity along the appropriate axes as marked on the front panel of the Beam Profiler.

The yellow curve shows the measured profile, while the red curve shows the approximated [Gaussian](#)¹⁴³ fit function and the blue - the approximated [Bessel](#)¹⁴⁴ fit. The curves can be shown / hidden by toggling the appropriate button above the diagram.







If "Autoscale to Peak" is enabled, the measured curve shows relative intensities from 0 to 100%, where 100% denotes the maximum value of intensity on X and Y axis.

If the "Autoscale to Peak" function is disabled, the X and Y profiles will show a peak amplitude equal to the AD converter saturation of the appropriate slit pair.

The amplitude of the Gaussian fit curve may be lower or even higher than the peak intensity of the measured curve.

The selected clip level (default 13.5%) is displayed if the "Auto Scale to Peak" function is enabled (button )

The horizontal scale is displayed in μm .

Toolbar Icon	Associated Action
	Opens a dialog box to specify the properties of the saved screenshots / diagrams.
	Opens a dialog box to save measurement data to XLS or CSV file.
	Toggle button to display grid in the diagram. Default: grid is shown.
	Zoom Home button
	Cursor mode - toggle button to show or hide the cursor.
	Show / Hide calculation area

Cursor Mode

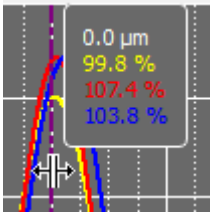

Move the mouse pointer close to the vertical cursor line. The mouse pointer changes to . The cursor line can be moved with the left mouse button pressed to a position inside the diagram. The current values at the cursor position are shown in a rectangle next to the cursor in the colors of the plotted curve.

6.6.4 Zooming and Panning Diagrams

All diagrams, e.g. X and Y profiles, plot diagrams, M^2 and divergence diagrams, that have a slider, can be manipulated for X and Y scale (zoom) as well as for X and Y positioning (pan).

Zoom Mode



To zoom in the diagram, draw a rectangle with the left mouse button pressed. Right click the diagram to revert to the last zoom action.



Zoom Home button returns to display of the complete diagram.

Zooming the Diagram Axes



Move the mouse cursor over an edge of the vertical or horizontal scroll bar slider. The cursor changes to  or . Press and hold left mouse button and move the mouse. This will zoom in on the appropriate part of the diagram axis. Return to default view using the Zoom Home button.

Panning the Diagram Axes



Move the mouse pointer over the center of the vertical or horizontal scroll bar slider and press left mouse button. Now the slider can be moved to pan (shift) across the diagram. Return to default view using the Zoom Home button.

6.6.5 Calculation Results

In this window the results of the calculations are displayed as derived from the raw data or the fitted ellipse. The window can be opened and closed via the menu item "Calculation Results" in the window menu or via the toggle button in the toolbar .

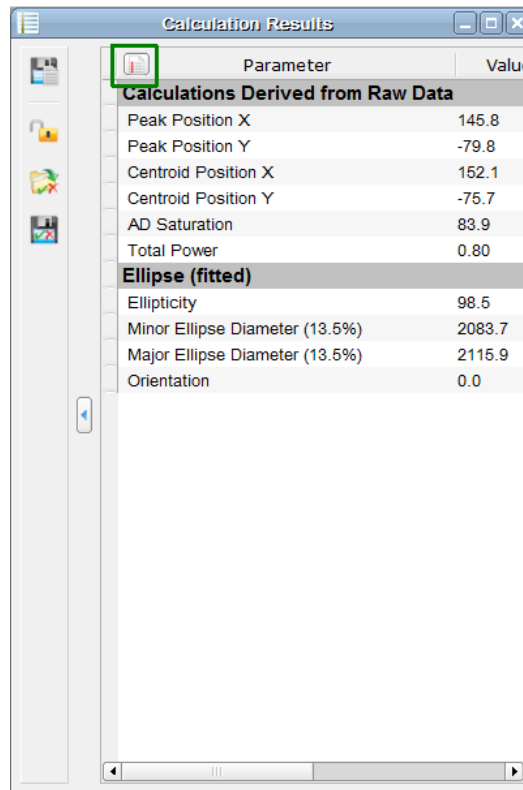

	Parameter	Value
Calculations Derived from Raw Data		
<input type="checkbox"/>	Peak Position X	145.8
<input type="checkbox"/>	Peak Position Y	-79.8
<input type="checkbox"/>	Centroid Position X	152.1
<input type="checkbox"/>	Centroid Position Y	-75.7
<input type="checkbox"/>	AD Saturation	83.9
<input type="checkbox"/>	Total Power	0.80
Ellipse (fitted)		
<input type="checkbox"/>	Ellipticity	98.5
<input type="checkbox"/>	Minor Ellipse Diameter (13.5%)	2083.7
<input type="checkbox"/>	Major Ellipse Diameter (13.5%)	2115.9
<input type="checkbox"/>	Orientation	0.0

The width of the columns is predefined but can be resized. With the first start of the Beam Software, the parameters as shown above are displayed in this table. Click the marked green  icon in the table in order to select or deselect parameters to be calculated and displayed. The fewer calculation results are enabled, the higher the speed performance of the software.

Select / Deselect All

Calculations Derived from Raw Data

Beam Width (4-Sigma) X
 Beam Width (4-Sigma) Y
 Peak Position X
 Peak Position Y
 Peak Position R
 Centroid Position X
 Centroid Position Y
 Centroid Position R
 AD Saturation
 Total Power

Ellipse

Ellipticity
 Minor Ellipse Diameter
 Major Ellipse Diameter
 Mean Ellipse Diameter
 Eccentricity
 Orientation

Profile Measurement

Beam Width Clip X
 Beam Width Clip Y

Fit Measurement

Gaussian Intensity X
 Gaussian Intensity Y
 Gaussian Diameter X
 Gaussian Diameter Y
 Bessel Intensity X
 Bessel Intensity Y

Environment Parameter

Note





- Even if the Gaussian and / or Bessel Fit calculations are disabled from display in the Calculation results panel, the appropriate fitted curves are still shown in the X and Y Profile windows, if enabled there.

The units of the calculations can be changed in [Beam Settings / Unit](#)³⁶.

If a calculation failed the value turns to "--".

For details on these parameters, please see section "[Application Note](#)"¹⁴¹

Handling of Calculation Results and Settings

Toolbar Symbol	Associated Action
	Save Calculation Results
	Lock / Unlock Test Parameters
	Load Test Parameter Configuration
	Save Test Parameter Configuration

Save Calculations opens a dialog box:

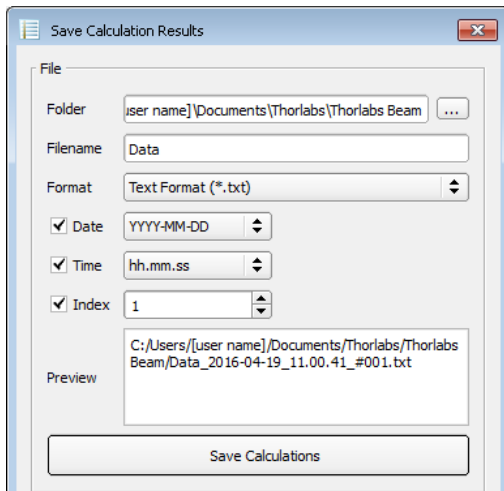

- Select the destination folder (see the preview pane)
- Define the file name
- Select file format (*.txt, *.csv or *.xls)
- Add date, time stamp, index (optional)
- Click "Save Calculations"

Lock / Unlock Test Parameters; Load / Save Test Parameter Configuration.

These functions are related to the configuration of the [Pass / Fail Test](#)⁶⁶ functionality.

Sequential Saving

This feature is used to save sequentially sets of the [selected calculation results](#)⁴⁵, e.g for a long term analysis.

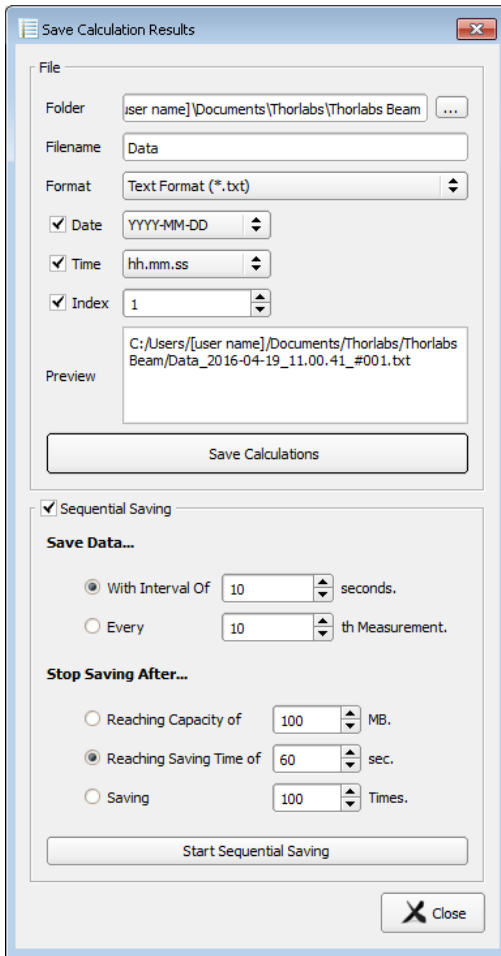

- Select the destination **folder** (see the preview pane).
- Define the file name.
- Select the export format.
- Add date and/or time stamp (optional)
- **Save Data...** Select either
 - the time interval between two records (1 to 10^6 sec.)
 - or
 - the n-th measurement to be recorded ($n = 1$ to 10^5)
- **Stop Saving after...** Define when the sequential saving shall be terminated:
 - after reaching a certain file size (1 to 100 MB)
 - after reaching a certain recording time (1 to 10^6 sec.)
 - after reaching a certain number of data sets (1 to 10^5)
- Click "Start Sequential Saving"

The data sets are recorded to one single file, with each new record appended to the previously recorded data sets.

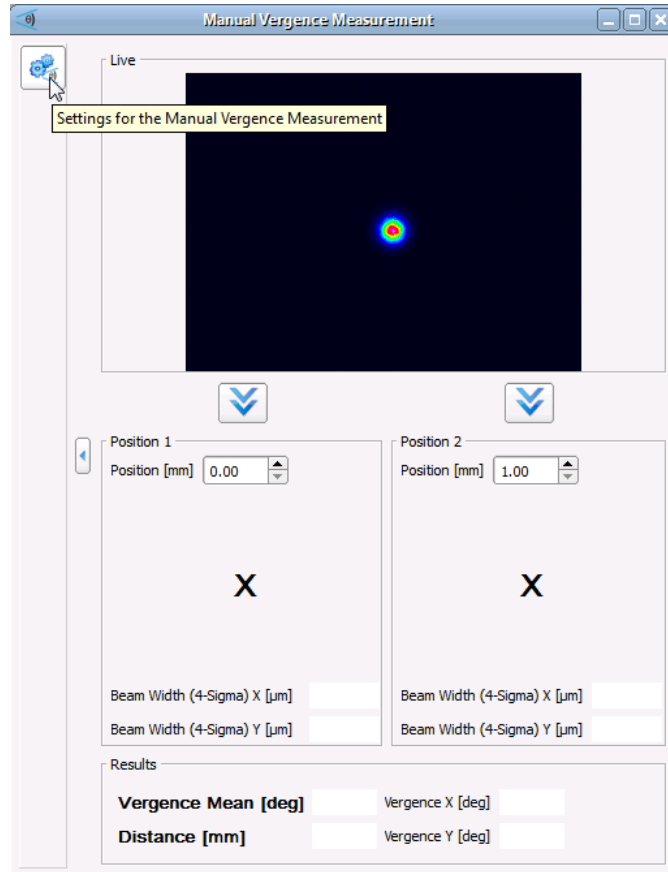

6.6.6 Manual Vergence Measurement

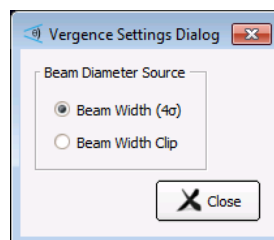

Vergence refers to the divergence or convergence angle of a light beam. The manual vergence measurement allows this angle to be measured using a simple mechanical setup. The Beam Profiler is mounted so that it can slide along the beam propagation trace. This can be done using, for example, a Thorlabs [M2 translation stage](#) or a Thorlabs [RLA Series](#) of dovetail optical rails in combination with a [RC series](#) rail carrier and a post.

Open the Manual Vergence Measurement Window either by selecting the appropriate item from the Menu bar (Windows → Manual Vergence Measurement) or simply by clicking the  icon:



1. Click the  icon in the left upper corner to open "Settings for the Manual Vergence Measurements". Select the beam diameter calculation method. Measure the distance between the light source and the front plane of the Beam Profiler and enter this value to the box "Position 1" in millimeters and click the .



2. The software calculates the beam width at Position 1.



3. Move the Beam Profiler, measure the distance again, enter the new distance into the box "Position 2" and press the 2nd  icon.
4. The beam width at Position 2 is calculated and based on the entered distance change, the vergence angle in X and Y axes is displayed.

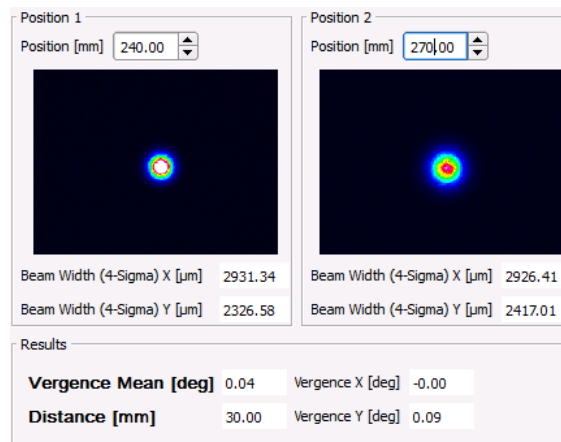

Note

The accuracy of the entered distance between the two positions (shift) of the Beam Profiler is significant for vergence measurement accuracy.

Hint

If you are using the Beam Profiler together with a M2MS Extension Set, the Manual Vergence measurement is even more simple:

- Remove the focusing lens from the system.
- Feed the laser beam into the M2MS-BP209x input aperture and align it.
- Open in the Beam Settings panel the [Translation Stage Control](#)³⁷ topic.
- Use the stage slider to set 0 and 200 mm positions and proceed as described above.

6.6.7 Tuning View

The Tuning View child window allows selectable values to be displayed in an analog way, which can be helpful for adjusting the optical setup.

Select from the Menu bar (Windows -> Tuning View) or simply click the  icon. The tuning view can display either two needle scales or 4 bar graphs. Each scale or graph can be assigned to one of the following parameters:

- Sensor Saturation
- Total Power
- Ellipticity
- Beam Width 4σ (X)
- Beam Width 4σ (Y)
- Peak Position X
- Peak Position Y
- Centroid Position X
- Centroid Position Y
- Ellipse Diameter min.
- Ellipse Diameter max.
- Beam Width Clip X
- Beam Width Clip Y

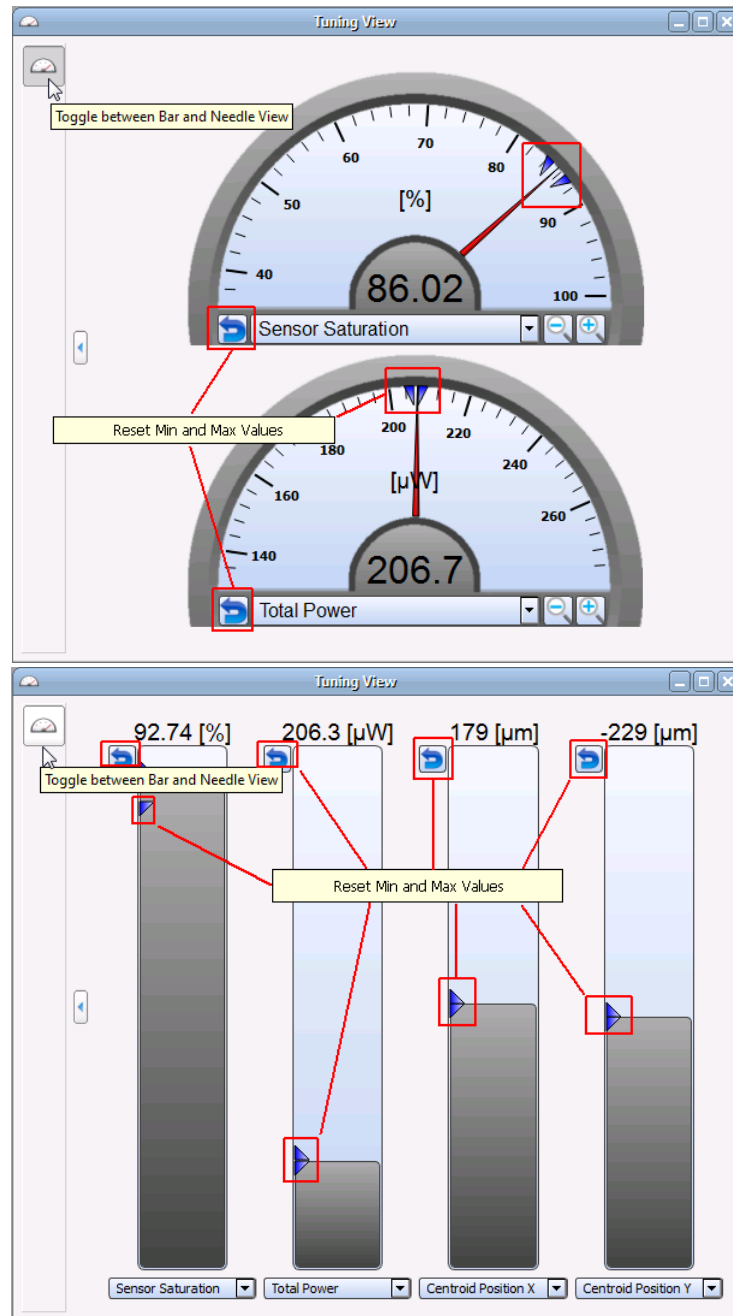

On the scales, the observed minimum and maximum values are shown as blue triangles. They can be reset using the  buttons marked above.

6.6.8 Beam Overlapping

The Beam Overlapping tool is useful to adjust the location of a light beam. For example, two sources can be adjusted in such way that their spots overlap at a certain location and are concentric.

Select from the Menu bar (Windows -> Beam Overlapping) or simply click the  icon.

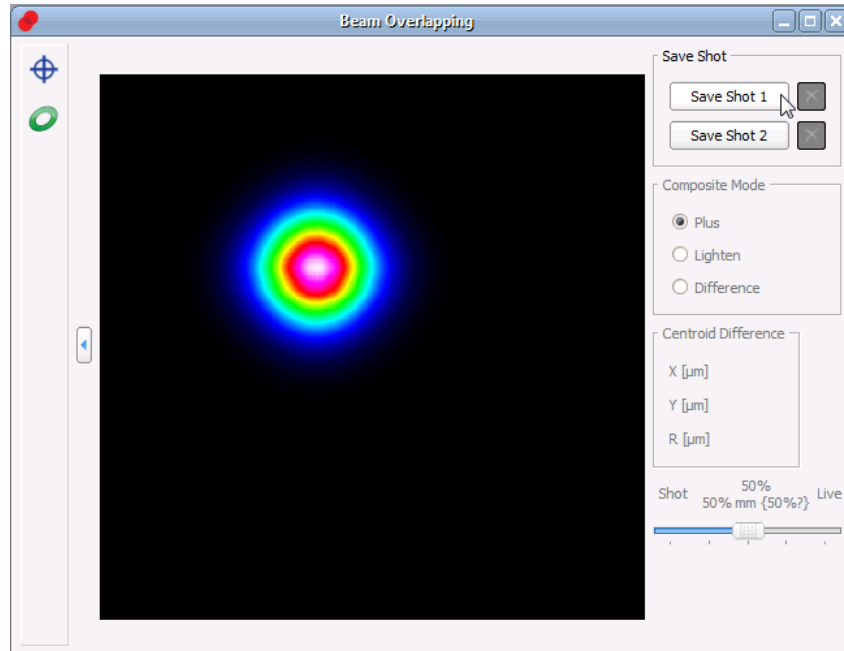

Take a snapshot of the reference position by clicking to the button "Save Shot 1" or "Save Shot 2". The software instantly starts to overlay the live 2D reconstruction from the Beam Profiler with the captured snapshot. The overlay method can be selected in the box "Composite Mode":

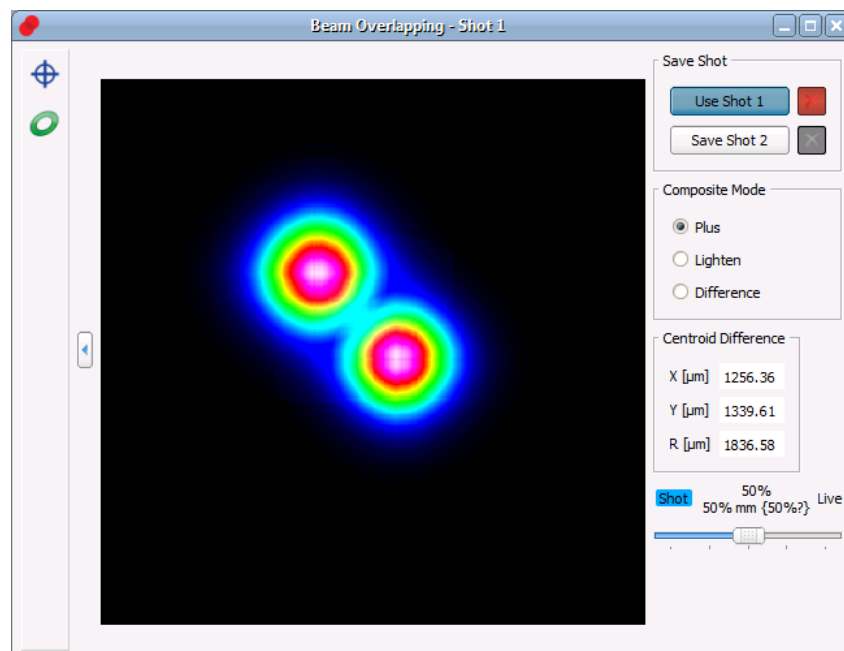

Overlay "Plus"

In "Plus" mode the intensities of the snap shot and the live image are added. This eases the adjustment particularly of regions with lower intensity.

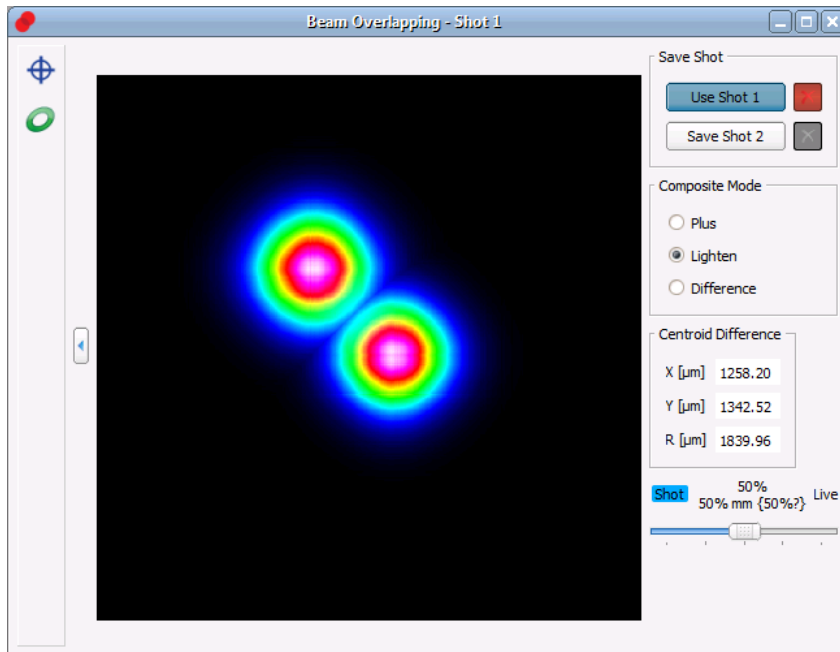

Overlay "Lighten"

In "Lighten" mode, within the overlapping region only the "pixel" with higher intensity will be displayed; the intensities of the snapshot and the current beam are not added.

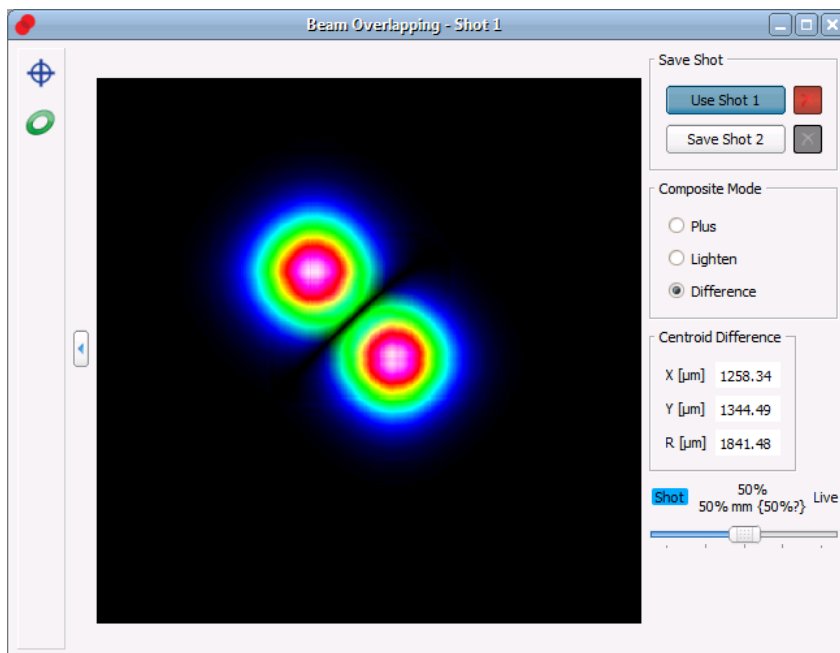

Overlay "Difference"

Finally, in the "Difference" mode, the intensities are subtracted. The more regions appear black within the overlay, the better the live image fits to the snapshot.

The centroid shift between snapshot and live image is displayed in X and Y axis direction, R is the resulting absolute distance between these centroids.

For improved visualization of the overlay, the intensities of the snapshot and the live image can be weighted in 25% steps (slider).

6.6.9 Plots

Thorlabs Beam Software offers several additional plot windows to show the beam behavior:

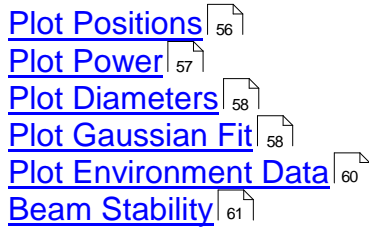



All plot windows are accessible via the "**Windows**" menu, while **Plot Positions**, **Plot Power** and **Beam Stability** also have buttons in the toolbar. The diagrams can be cleared using the "Clear Windows" command (Menu Bar -> Control or  button).

Convenient view functions allow a detailed analysis of the parameter's behavior over time.

- **Display / Hide** a certain parameter: Appropriate buttons are located above the diagrams.
- **Zoom Out:** Press and hold left mouse button and mark the desired diagram area.
- **Undo Zoom:** Right click on the diagram to reproduce the previous zoom status.
- **Zooming Diagram Axes**



Move the mouse cursor over an edge of the vertical or horizontal scroll bar slider. The cursor changes to  or . Press and hold left mouse button and move the mouse. This will zoom in on the appropriate part of the diagram axis. Return to default view by right clicking to the diagram.

- **Panning the Diagram Axes**



Move the mouse pointer over the center of the vertical or horizontal scroll bar slider and press left mouse button. Now the slider can be moved to pan (shift) across the diagram. Return to default view using the Zoom Home button.

- **Autoscale:** This button in the left toolbar returns the diagram to default view (auto scaled).
- **Cursor Mode:** If the mouse position is near to the vertical cursor line, the mouse cursor changes to . The cursor line can be moved with the left mouse button pressed to a position inside the diagram. The current values at the cursor position are shown in a rectangle next to the cursor in the colors of the plotted curve.





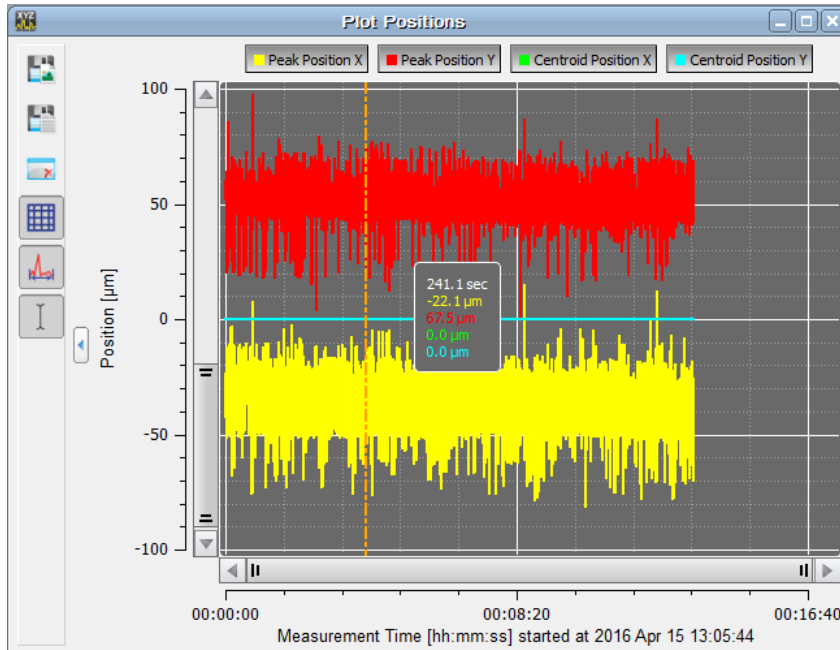

The individual plot windows are explained in detail in the next sections.

6.6.9.1 Plot Positions

Toolbar:  , Menu bar: Windows -> Plot Positions



The positions of X and Y peak and of X and Y centroid positions can be displayed vs. time.

Toolbar Icon	Associated Action
	Save Diagram or Image: Opens a dialog box to specify the properties of the saved diagram or image.
	Save Data: Opens a dialog box to specify the properties of the saved calculation data
	Clear all plots
	Show or Hide the grid in the diagram:
	Autoscale ON/OFF
	Show or hide the cursor

6.6.9.2 Plot Power



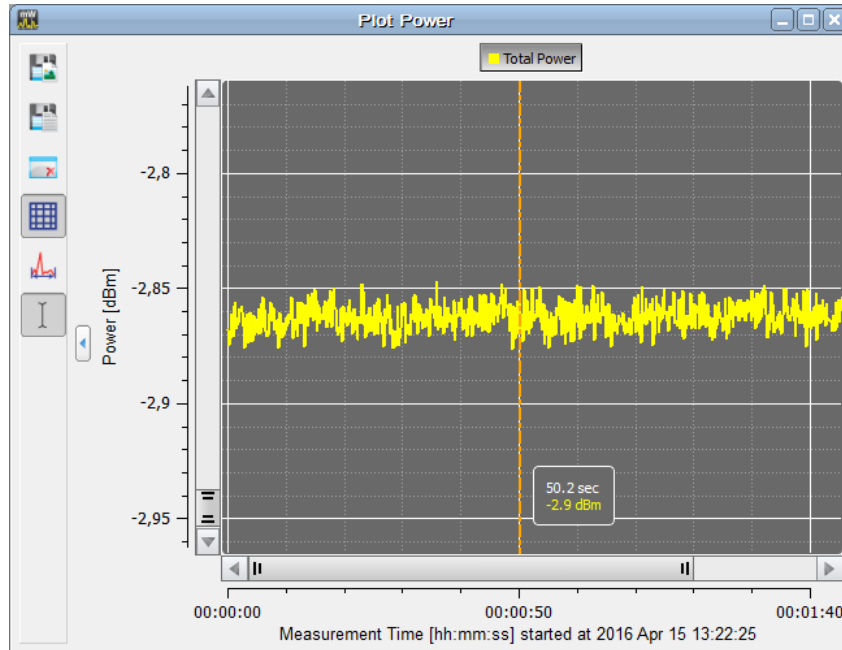



Toolbar: , Menu bar: Windows -> Plot Power



The total power measured by the Beam Profiler vs. time can be displayed.

Note

The power indication of Thorlabs Beam Profiler instruments is not calibrated vs. wavelength, it is based on a typical responsivity curve of the used photo diode and the manually entered wavelength (see [Optical Setup / Wavelength](#) ²⁷)

Toolbar Icon	Associated Action
	Save Diagram or Image: Opens a dialog box to specify the properties of the saved diagram or image.
	Save Data: Opens a dialog box to specify the properties of the saved calculation data.
	Clear all plots
	Show or Hide the grid in the diagram:
	Autoscale ON/OFF
	Show or hide the cursor

6.6.9.3 Plot Diameters

Menu bar: Windows -> Plot Beam Diameters

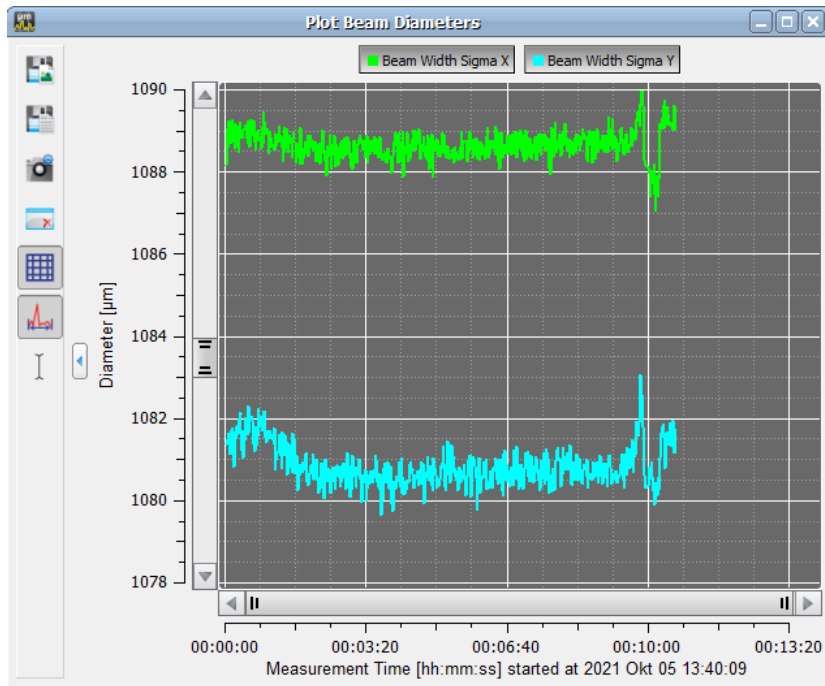

The Plot Diameters window displays the beam diameter over time as the user adjusts settings. This allows to easily monitor the behavior of the beam diameter.



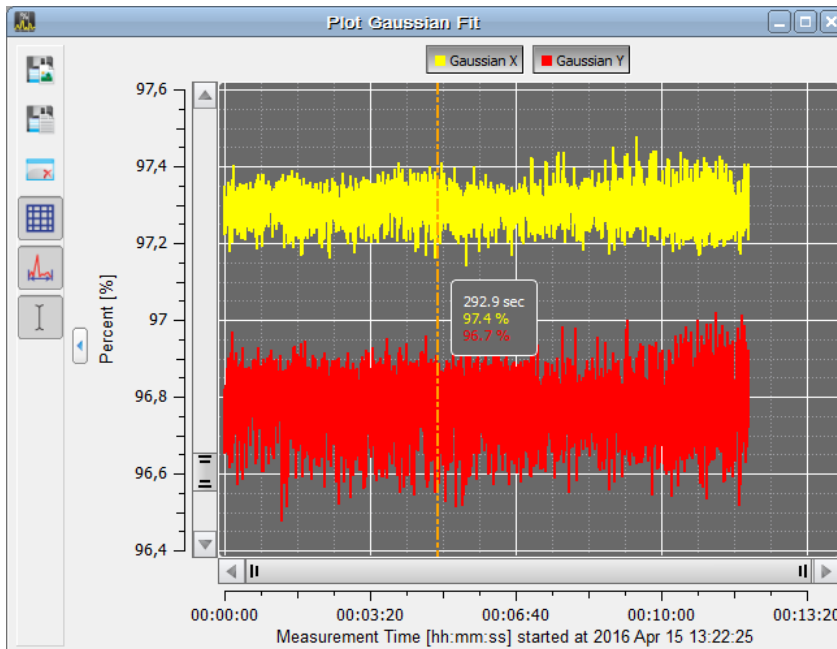

6.6.9.4 Plot Gaussian Fit

Menu bar: Windows -> Plot Gaussian Fit



This window plots the Gaussian Intensity value (see [Calculation Results](#)⁴⁵⁾) which shows the coefficient of determination of the fit.

Toolbar Icon	Associated Action
	Save Diagram or Image: Opens a dialog box to specify the properties of the saved diagram or image.





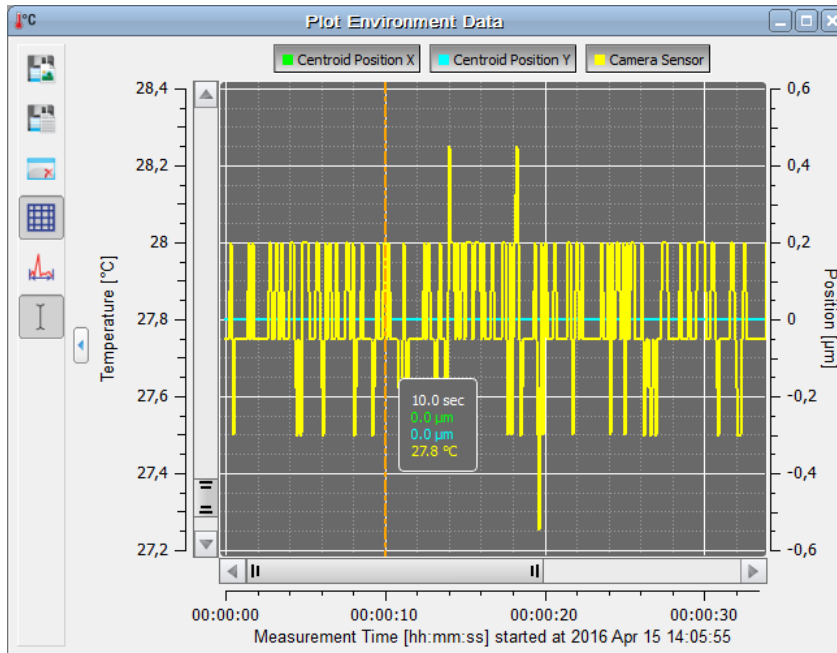

Toolbar Icon	Associated Action
	Save Data: Opens a dialog box to specify the properties of the saved calculation data
	Clear all plots
	Show or Hide the grid in the diagram:
	Autoscale ON/OFF
	Show or hide the cursor

6.6.9.5 Plot Environment Data

In this window the position of the X and Y centroids can be logged together with the reading of an externally connected Thorlabs TSP01 temperature sensor vs. time.



The temperature axis is located to the left (yellow curve), the centroid position axis (blue and green curves) is shown to the right.

Toolbar Icon	Associated Action
	Save Diagram or Image: Opens a dialog box to specify the properties of the saved diagram or image.
	Save Data: Opens a dialog box to specify the properties of the saved calculation data
	Clear all plots
	Show or Hide the grid in the diagram
	Autoscale ON/OFF
	Show or hide the cursor

6.6.9.6 Beam Stability

Toolbar: , Menu bar: Windows → Beam Stability

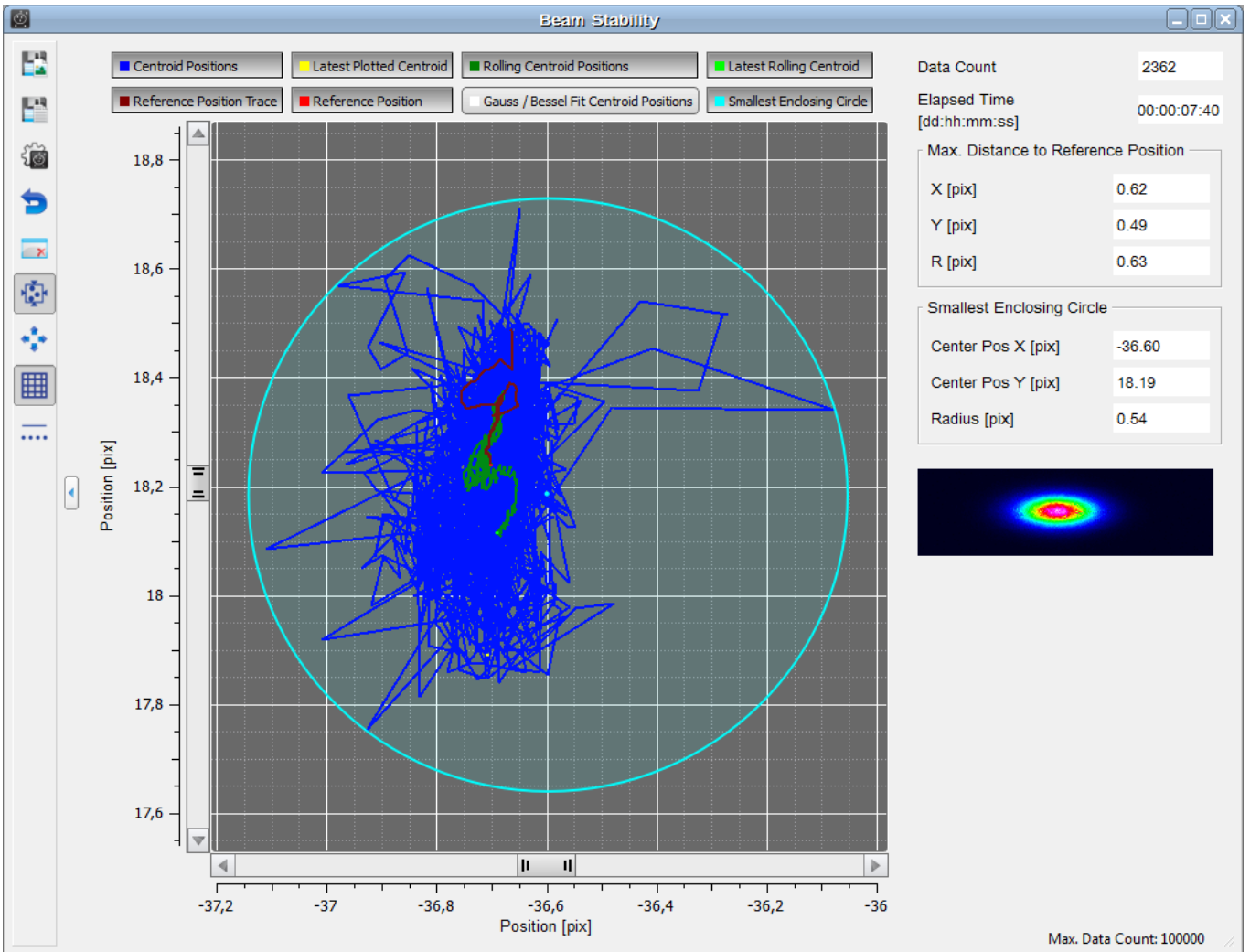

This feature allows the beam stability vs. time to be recorded in a very versatile way. Accumulated data are accessible from the graphic display by enabling several plots:









- Centroid Positions Plots the trace of the centroid positions as a blue line
- Latest Plotted Centroid Plots the most recent centroid position as yellow dot
- Rolling Centroid Positions Plots the trace of the [rolling centroid positions](#)³⁴ as a dark green line
- Latest Rolling Centroid Plots the most recent rolling centroid position as a bright green dot
- Reference Position Trace Plots the trace of the [reference positions](#)⁶² as dark red line
- Reference Position Plots the reference position as a bright red dot
- Gauss_Bessel Fit Centroid Positions Plots the Gauss / Bessel fitted centroid positions
- Smallest Enclosing Circle Plots the smallest enclosing circle around centroid position cloud
- Centroid Positions Plot disabled
- Centroid Positions Plot enabled

Most of the beam stability characteristics are given in numeric units:

Data Count: The actual count of displayed measurement results.

Elapsed Time: Time since last start of stability measurement

Max. Distance to Reference Position of the centroid positions is given in distance (X), distance (Y) and as radial distance (R). The reference position can be defined in the Settings Dialog (see below the [table](#)^[62]) as either the oldest centroid position or the center of the centroid positions data cloud.

Toolbar Icon	Associated Action
	Save Diagram or Image: Opens a dialog box to specify the properties of the saved diagram or image.
	Save Data: Opens a dialog box to specify the properties of the saved calculation data
	Shows the Settings Dialog (see below)
	Reset Data: Clears Beam Stability data only
	Stops and restarts the measurements, clears all accumulated plot data
	Sets the zoom factor so that all data points are located within the diagram area
	Zoom out to the entire sensor area
	Show or Hide the grid in the diagram:
	Display results as dots or wired

Settings Dialog

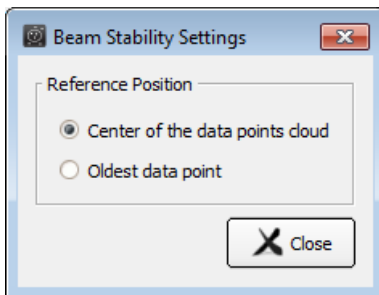

Reference Position: Reference for calculation of beam stability. Can be set to the center of the data cloud or to the oldest displayed data point.

Note

The maximum number of data points to be displayed, the handling of data points after reaching the maximum and the time interval between two displayed data points is set in the menu [Beam Settings / Plot over Time Parameter](#)^[36].

7 Operation Instructions

7.1 Measurement with the Beam Profiler

General Guidelines for Operating the BP209 Series Slit Scanning Beam Profiler

To achieve correct and reliable measurement results, it is recommended that these basic guidelines are followed.

1. Provide stable mounting of the Beam Profiler using appropriate threads on its [mounting plate](#)^[12].
2. In the Beam Software:
 - a. Enter the correct [operating wavelength](#)^[27].
 - b. Perform a [Power Correction](#)^[28].
3. Be sure to operate the instrument within its specified [Power Range](#)^[150].
4. Align the beam to be measured so that it is perpendicular to the front face of the Beam Profiler.
5. Minimize ambient light entering the Beam Profiler aperture. .

Attention

Do not stick anything into the Beam Profiler aperture! There is no glass or other protective barrier to protect the thin slit foils, the bearings of the motor, and/or the rotating drum.

Prevent dust or other contamination from entering the aperture!

Keep beam power below the allowed limit to avoid damage to the instrument!

Software Performance Optimization

As soon as a BP209 Series device is selected within the "Device Selection" panel, the measurement starts in the continuous mode. It may be advantageous to stop the continuous measurement for a detailed analysis of a beam profile captured with the last image. Also, user interactions with the GUI will work more fluently when the continuous flow of image data is stopped.

Measurement speed of the Beam Profiler depends on various device settings like the scan rate (rotation speed of the scanning drum), target resolution, gain and bandwidth of the amplifier. Also the number of open child windows used to visualize the measured results and the number of activated numerical parameters to be calculated may reduce the available display update rate, depending on the performance of your PC.

Note

For accurate measurement results (power values, M^2 results) the correct wavelength must be entered. Thorlabs Beam Profiler instruments are not calibrated for power with respect to the wavelength. The power calculation is based on a typical responsivity curve of the used sensor and manually entered wavelength (see [Beam Settings / Optical Setup](#)^[27]).

7.1.1 Operating the Instrument

Be sure that the Beam Profiler is connected to the PC and the driver is installed properly as described in the chapter Connection to the PC.

At the initial program start, the GUI opens and displays the [Beam Settings](#)^[26] panel, the [Calculation Results](#)^[45], [2 D](#)^[40] Reconstruction and [3D Profile](#)^[42]. [Child windows](#)^[39] can be opened and closed via the entries in the menu "Window" or via the symbols in the toolbar of the main window. The activated windows can be sized and arranged as desired.

The recognized Beam Profiler will be connected automatically, and the continuous image acquisition starts.

If more than one device was recognized during the initial application start, the first recognized device will be connected and started. Please see section [Start the Application](#)^[14] for details on how to select a different device.

Verify the settings in the section [Optical Setup](#)^[27] if you have started the Beam Software for the first time. For more details on the hardware settings please see the section [Slit Beam Profiler Parameter](#)^[30].

Note

The configuration of child windows is saved when the BEAM software is closed. On the next software instance, the BEAM software is next opened, these windows and their last positions and appearances are restored. Also, the most recent device selection will be restored when re-starting the BEAM application, together with the most recent settings that were made in the settings panel.

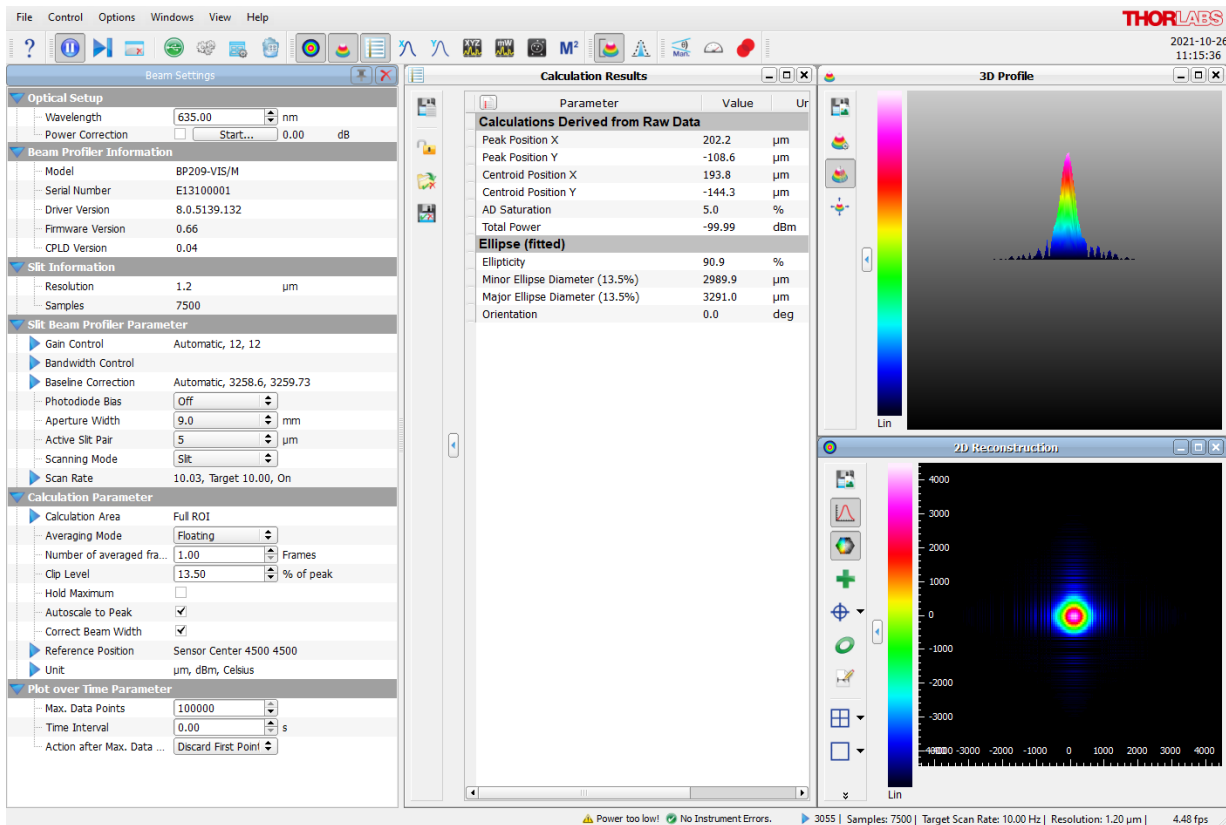

The child window [2D Reconstruction](#)^[40] shows the measured intensity distribution across the sensor area in gray or color scale whereas the [3D Profile](#)^[42] is plots the beam intensity with respect to the 3rd dimension (Z scale). Numerical calculation results are displayed in the appropriate [Calculation Results](#)^[45] window. The parameters to be calculated can be selected by clicking the  icon in left upper corner the [Calculation Results](#)^[45] window.

All contents of the child windows including available options are explained in chapter [Child Windows](#)^[39].

7.1.2 Pass/Fail Test

The Calculation Results panel includes a pass/fail test for reproducible assessment of light beams.

Parameter	Value	Unit	Test	Min.	Max.
Calculations Derived from Raw Data					
Beam Width (4-Sigma) X	2739.23	μm	Pass	2600.00	2800.00
Beam Width (4-Sigma) Y	2664.65	μm	Pass	2600.00	2800.00
Peak Position X	14.55	μm		0.00	0.00
Peak Position Y	-77.29	μm		0.00	0.00
Centroid Position X (Reference Position)	0.00	μm		0.00	0.00
Centroid Position Y	0.00	μm		0.00	0.00
AD Saturation	76.83	%	Pass	65.00	95.00
Total Power	3.68	mW	Fail	4.00	5.00
Ellipse (fitted)					
Ellipticity	97.44	%	Pass	95.00	100.00
Minor Ellipse Diameter (13.5%)	2592.75	μm	Pass	2500.00	2700.00
Major Ellipse Diameter (13.5%)	2660.94	μm	Pass	2500.00	2700.00
Eccentricity	22.49	%		0.00	0.00
Orientation	--	deg		0.00	0.00
Profile Measurement					
Beam Width Clip X (13.5%)	2704.28	μm	Pass	2600.00	2800.00
Beam Width Clip Y (13.5%)	2625.48	μm	Pass	2600.00	2800.00
Fit Measurement					
Gaussian Intensity X	92.19	%		0.00	0.00
Gaussian Intensity Y	92.44	%		0.00	0.00
Gaussian Diameter X	2659.29	μm		0.00	0.00
Gaussian Diameter Y	2591.14	μm		0.00	0.00
Bessel Intensity X	94.97	%		0.00	0.00
Bessel Intensity Y	95.08	%		0.00	0.00

For each parameter a minimum and / or maximum can be set as criteria.

Pass / fail test criteria can be set to "not below minimum", "not above maximum" by setting the check at Min. or Max., or "between minimum and maximum" by checking the appropriate boxes both, the **Min.** and **Max.** columns.

Test results will be displayed in the column **Test** only for those parameters that are selected as test criteria:

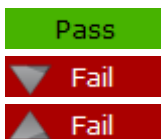

The selected test criteria was fulfilled; test passed.

The test criteria **Min.** was underrun; test failed

The test criteria **Max.** was exceeded; test failed





Note

As per definition, the beam ellipse has a major and a minor axis. For a pass / fail test, a minimum and maximum value can be entered in the fields for minor and major ellipse diameter. In the example given above, the "pass" ranges are:

- Minor axis diameter must be between **Min.** = 2500 and **Max.** = 2700 μm
- Major axis diameter must be between **Min.** = 2500 and **Max.** = 2700 μm

The test is passed only if both conditions are fulfilled.

Handling Pass / Fail Test Settings and Results

Toolbar Symbol	Associated Action
	Save Calculation Results
	Lock / Unlock Test Parameters
	Load Test Parameter Configuration
	Save Test Parameter Configuration

Save Calculations opens a dialog box to enter file properties (name, format, comments). For details please see the [Calculation Results](#)^[47] section.

Lock By default, pass/fail test parameters are unlocked. They can be locked in order to prevent manipulation of margins and parameters included in pass/fail test. Optionally, the lock can be secured by entering a password.

Note

A password can be entered only once and cannot be changed! In case of troubles, please contact [Thorlabs](#)^[162] for a solution.

Load / Save Test Parameter Configuration.

The **Load** and **Save** buttons in the **Calculation Results** toolbar allow you to load and save the configuration of the pass/fail test.

In order to reconstruct a pass/fail test configuration automatically with the next session, save the parameter to a test parameter configuration file. This file will be loaded with the next start of the application. If more than one configuration file is saved, the most recently saved file will be loaded automatically.

To load a test parameter from a file click to the "Load Test Parameter" button and select the test parameter configuration file.

7.1.3 Save Measurement Results

In addition to allowing the [Calculation Results](#)^[47] to be saved, the Beam Software will:

- [Export Device Data](#)^[67]
- [Print Windows](#)^[69]
- [Save a Test Protocol](#)

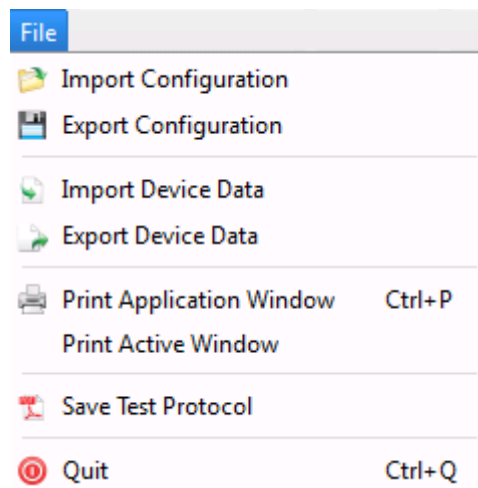

7.1.3.1 Export Device Data

To export data to a delimiter separated text document or an image, select "File → Export Device Data ..." from the Menu.

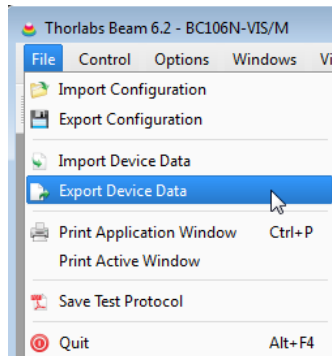

A dialog opens and asks for the type of file and the path where to save the file.

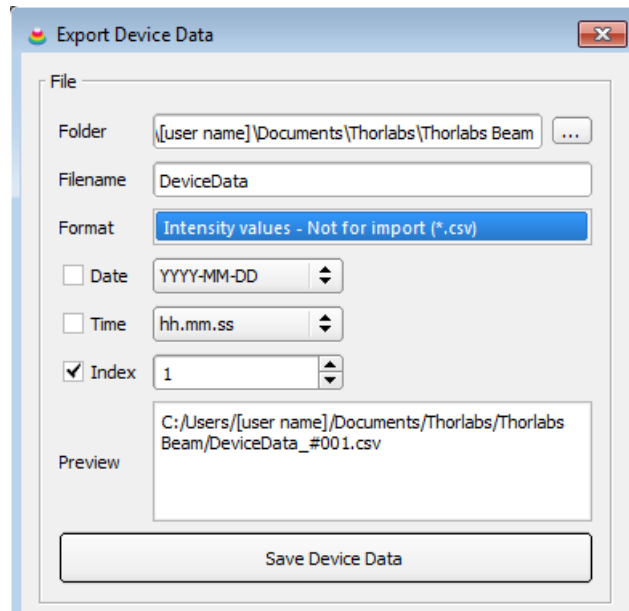

Select the desired path and file name

Intensity Value Text Matrix

This is a CSV (comma separated values) file format. The comment "Not for import" is related only to importing into the Beam Software: A data file cannot be imported in order to reconstruct a beam profile.

Intensity values are saved to a text matrix with a header:

Thorlabs Beam			
Version: 8.0.5152.310			
Date: 26.10.2021			
Time: 11:31:25			
Device: BP209-VIS/M			
S/N: E13100001			
ScanRate [Hz]: 10.0003			
Gain X: 5			
Gain Y: 5			
Bandwidth X [kHz]: 125.002			
Bandwidth Y [kHz]: 125.002			
Base Level X [digits]: 3267.12			
Base Level Y [digits]: 3266.16			
Wavelength [nm]: 635			
Pos X [μm]	X	Pos Y [μm]	Y
0	2.79e+01	0	8.84e+00
120.933	-6.12e+00	120.933	-5.02e+01
241.866	1.09e+01	241.866	1.68e+01

Sequential Saving

The export of measurement data described above can be repeated sequentially using the Sequential Saving feature on the bottom of the **Export Device Data** panel. This feature generates one single file per data set, with extending the file name created by appending an incremented index. The start index number can be freely selected between 1 and 10000. With each saved measurement, the index is incremented by 1.

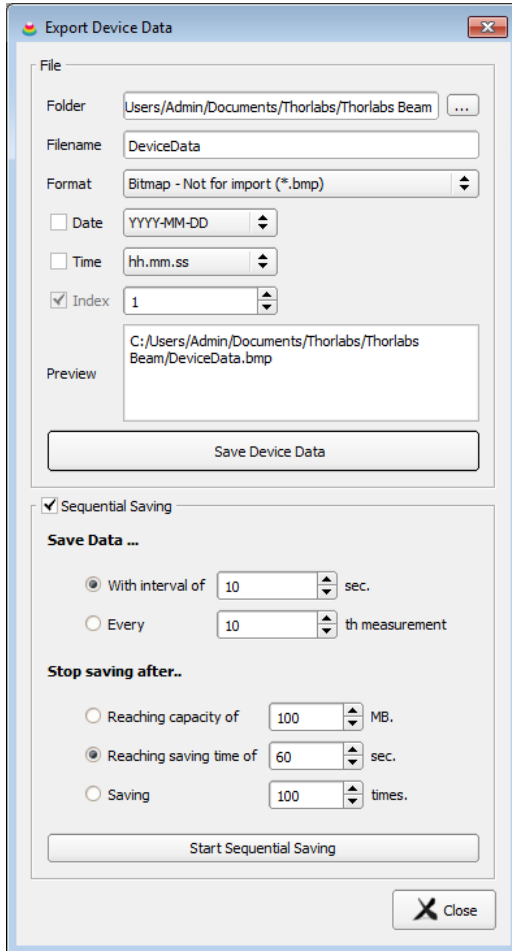

- Select the destination **folder** (see the preview pane).
- Enter the base file name.
- Select the export format.
- Add date and/or time stamp (optional)
- Check the box **Index** and define start index.
- Check the box "**Sequential Saving**"
- Save Data... Select either
 - the time interval between two records (1 to 10⁶ sec.)
 - or
 - the n-th measurement to be recorded (n = 1 to 10⁵)
- Stop Saving after... Define when the sequential saving shall be terminated:
 - after reaching a certain file size (1 to 100 MB)
 - after reaching a certain recording time (1 to 10⁶ sec.)
 - after reaching a certain number of data sets (1 to 10⁵)
- Click "Start Sequential Saving"

Attention

For sequential saving, an index value is appended to the selected file name. Make sure, the check box "Index" is marked.

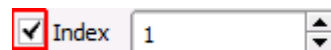

Once the box "**Sequential Saving**" is checked, the index-

ing is enabled automatically.

7.1.3.2 Print Windows

Select "File → Print Application Window" or "File → Print Active Window" to print screenshots of the appropriate window.

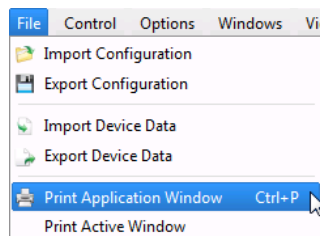

If a PDF creating software is installed as a printer, the screenshot can be printed also as a PDF file.

7.1.3.3 Save Test Protocol

To save a Test Protocol in pdf format select "File → Save Test Protocol".



A dialog box opens:

A screenshot of a "Test Protocol" dialog box. The dialog has a title bar with a close button. It contains several sections: "Test Protocol File" with a path field; "General Information" with fields for Test Organisation Name, Test Organisation Address, Name of Tester, and User Text; "Laser Information" with fields for Laser Type, Manufacturer, Manufacturer's Model Designation, and Serial Number; and "Test Conditions" with fields for Laser Wavelength, Profiler Azimuth Angle, Temperature, Operating Mode, Laser Parameter, Mode Structure, Polarization, and Environment Conditions. At the bottom right are "Save" and "Close" buttons.

Here, additional information can be entered in order to save it together with the test report.

The results of the measurement are saved to a compact test protocol. It contains the Beam Profiler data and settings and [selected numerical calculation results](#)⁴⁵. If the Reconstruction and the 3D Profile windows were activated, these plots will also be included.

Example:



Laser Beam Measurement Test Protocol

Measurement Instrument: Thorlabs Beam, version 8.0.5152.310
Date: 10-26-2021 11:41:03

Laser Wavelength: 635 nm

Model: BP209-VIS/M

Serial Number: E13100001

Scan Rate: 10.0003 Hz

Resolution: 1.2 μm

Parameter:	Result:	Unit:
Peak Position X	167.4	μm
Peak Position Y	-115.8	μm
Centroid Position X	200.2	μm
Centroid Position Y	-143.9	μm
AD Saturation	5.0	%
Total Power	-99.99	dBm
Ellipticity	94.7	%
Minor Ellipse Diameter	2785.3	μm
Major Ellipse Diameter	2941.5	μm
Orientation	0.0	deg

7.1.4 Pulsed Laser Sources

BP209 Series Beam Profilers can also be used to measure the profile of pulsed laser beams, although the better choice for such applications is the Thorlabs BC207 Series Camera Beam Profiler.

Pulsed laser sources with high repetition rate and short pulse duration can be measured in the same way as a CW laser. A typical example is a femtosecond laser, having repetition rates of up to 100 MHz and pulse durations below 100 fs.

In such case, the photo diode current amplifier due to its limited bandwidth "sees" not a pulse train, but virtually a CW signal.

The situation is different if the repetition rate is in the order of up to tens of kHz. In order to illustrate how to optimally setup the Beam Profiler, below are given two examples.

Used Laser System

- Thorlabs LPS-635-FC pigtailed laser diode with adjustable collimation package
- Controller Thorlabs ITC4001 in QCW mode ($f_{\text{rep}} = 1\text{kHz}$, $t_{\text{pulse}} = 100\mu\text{s}$)

Scan Rate Setting

The scan rate can be set between 2.0 and 20 Hz, so it cannot be set equal to the pulse repetition frequency. In the above case, if the scan rate is set to 10Hz, each 100th pulse will be scanned. Due to the high repetition frequency, previous and following pulses will also be displayed:

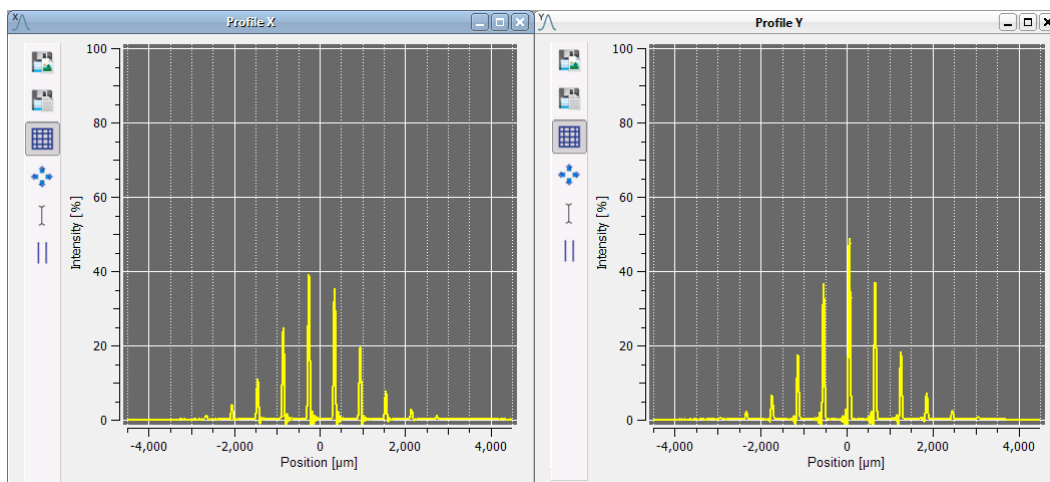

If set the scan rate in such way, that in X and Y profile the pulses move through the diagram (i.e., so that the pulse rate slightly differs from an integer multiple of the scan rate), and activate the max hold function  function, the software will accumulate the peak intensities over a number of subsequent pulses, and finally, the beam profile will be displayed - however, this is the averaged profile over a number of subsequent pulses.

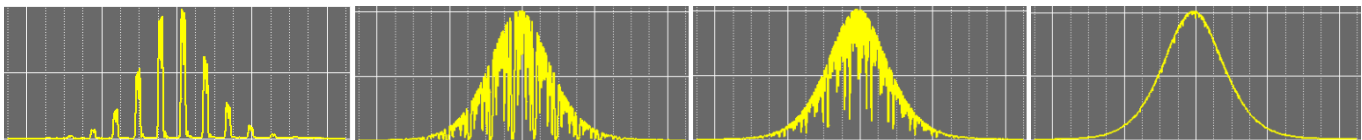

Note

The user should decide when the envelope shape smoothing can be considered to be finished.

Bandwidth Setting

It is recommended that the bandwidth be set manually. The guideline is the same as for CW signals - the smaller the beam diameter, the higher the bandwidth is required: Small beam diameters cause short photo diode current pulses when the slit is scanning it. If the BW is set too low, the rising edge of the photo diode current is delayed, and the falling edge overshoots. This leads to an artificially lower peak amplitude.

The X profile of a 130 μm beam illustrates this:

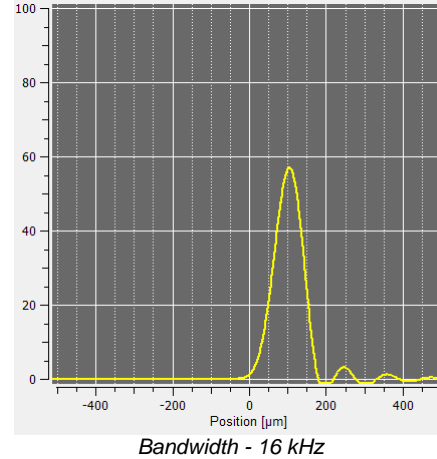
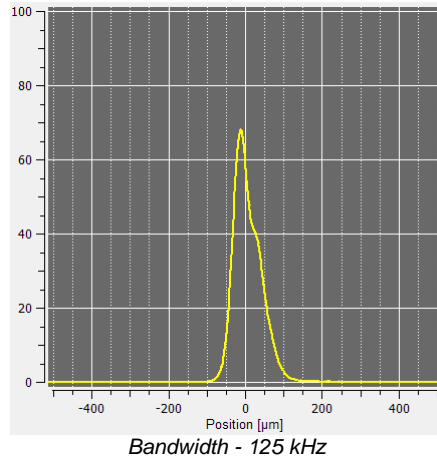

At larger beam diameters, higher bandwidth results in a higher noise level - as can be seen for a beam with of about 3 mm:

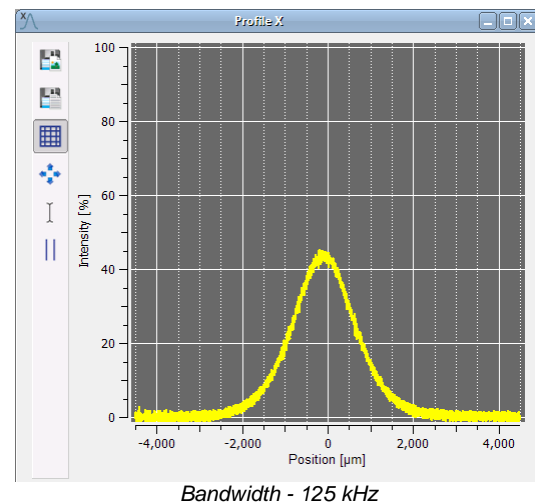
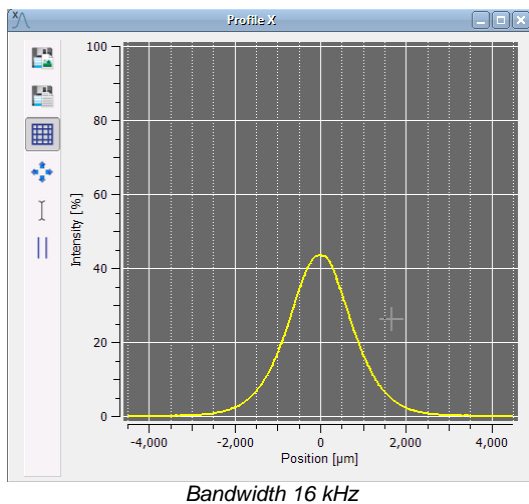

Gain Index

For pulsed lasers, it is recommended that the gain index be set manually in order to avoid saturation of the amplifier.

7.1.5 Knife Edge Mode

With the 5 μm slits, a beam diameter down to 20 μm can be measured in the standard slit scanning mode. For beam diameters below 20 μm , the BP209 models offer the so called Knife Edge Mode in combination with the 25 μm slit pair. As the beam diameter is smaller than the slit width, during the scan different portions of the beam pass the slit and are incident on the photo diode. This way, the measured power increases from zero to the total beam power, remains shortly at this level and subsequently drops to zero again.

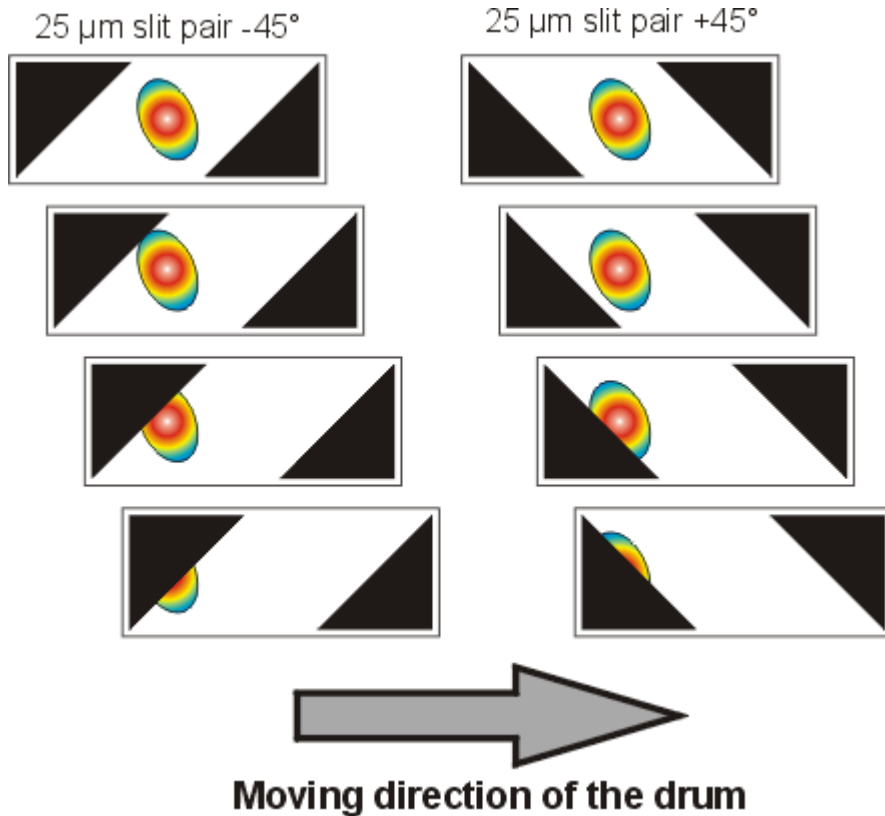

Since the drum position is known exactly, the original beam profile in the X and Y direction can be reconstructed with a good resolution.

The knife edge mode requires a proper beam alignment - the beam should hit the sensor as close to the center as possible. Further, the Beam Profiler must be set to its maximum resolution, i.e., minimum scan speed and maximum bandwidth.

Preparation

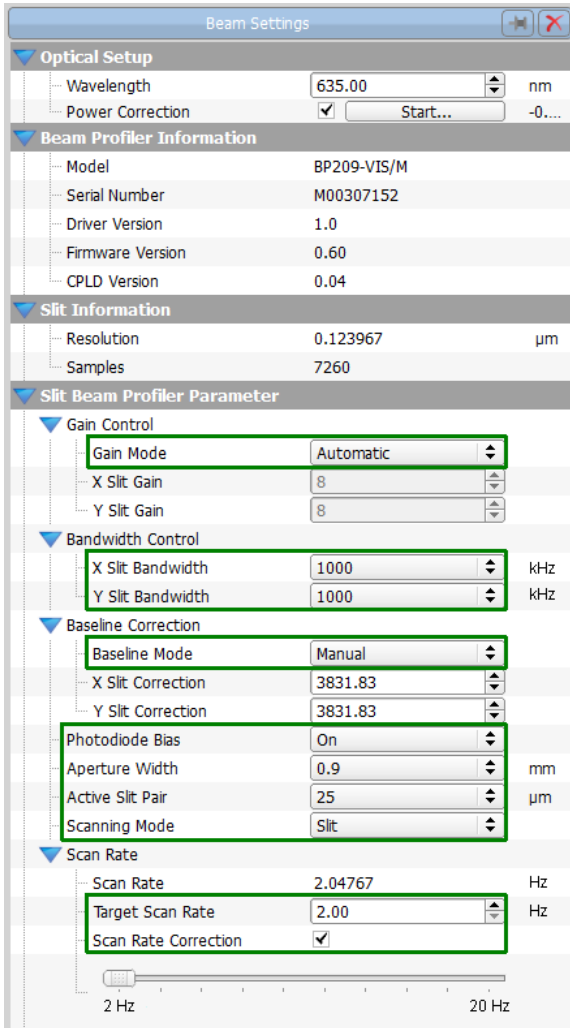

- Set Gain Mode to "**Automatic**".
- Set X and Y Slit Bandwidth to "**1000 kHz**".
- Set Base Line Mode to "**Manual**".
- Set Photodiode Bias to "**On**" - this shortens the rise/fall time of the photo diode.
- Set Aperture Width to "**0.9 mm**" - the software uses only an area of \varnothing 0.9 mm in the sensor center for calculation.
- Set Active Slit Pair to "**25 μm**".
- Set Scanning Mode (for alignment) to "**Slit**".
- Set Scan Rate to "**2 Hz**".
- Enable Scan Rate Correction.

Enable X and Y profiles.

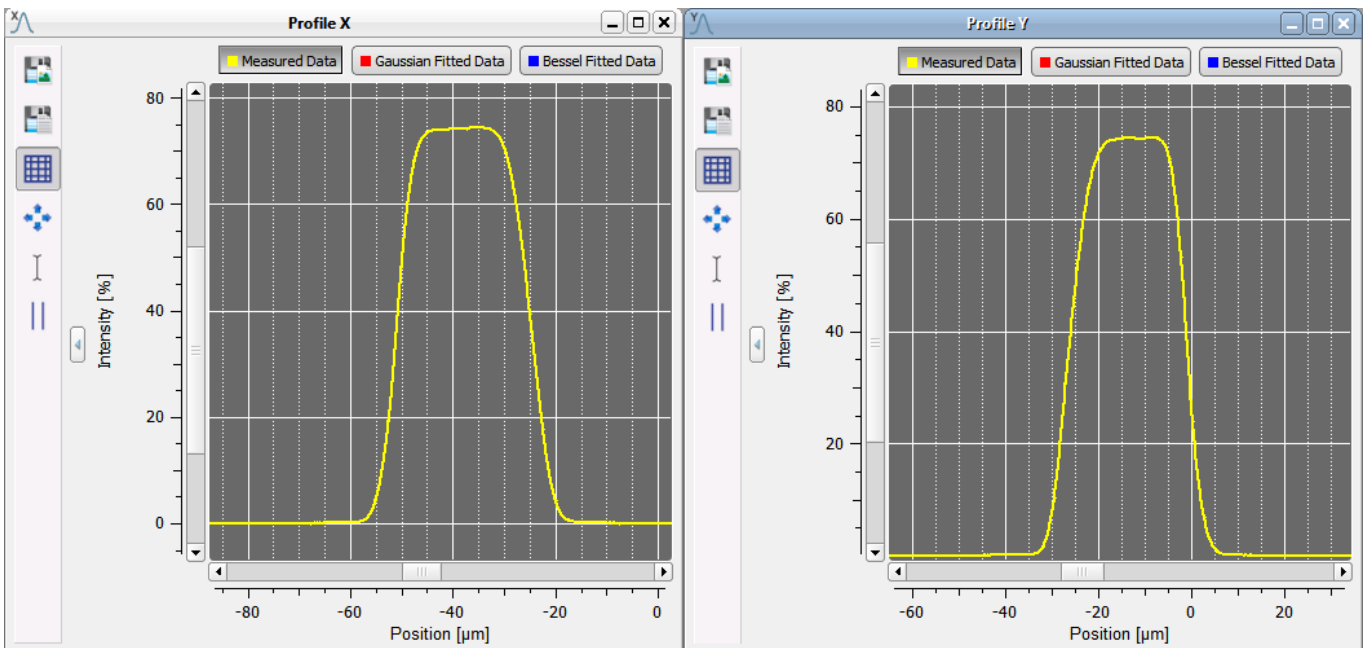

Disable Gaussian and Bessel fits and zoom in the profiles. A proper alignment is reflected in a maximum amplitude and a flat top of the profile. The flat top is a result of the small beam size

and the use of the 25 μm slits (see screen shots above). Then switch in the device settings dialog to Knife Edge mode:

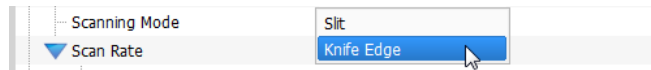

Two new child windows come up (they may overlay each other initially), showing the reconstructed knife edge profiles for the X and Y axis (green curve) along with the measurement data obtained in normal slit scanning method data (dimmed yellow curve):

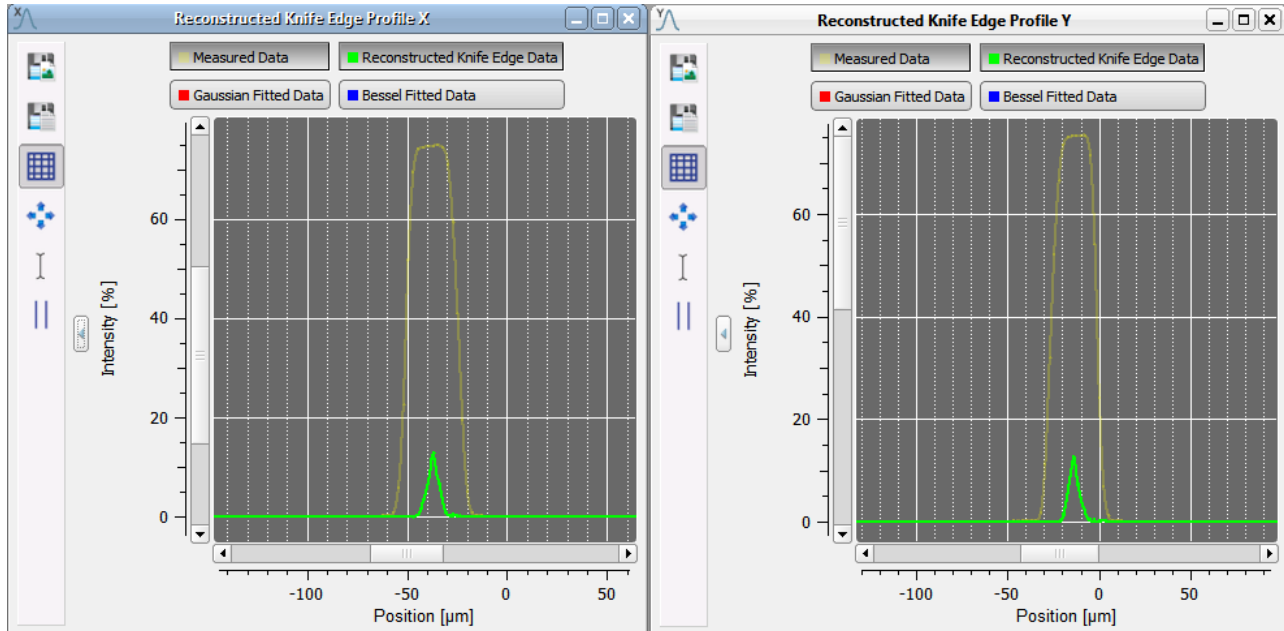

The numeric result window shows the beam parameters:

The screenshot shows a window titled 'Calculation Results' with a table of parameters. The table has three columns: 'Parameter', 'Value', and 'Unit'. The parameters are grouped into two sections: 'Ellipse (fitted)' and 'Profile Measurement'.

Parameter	Value	Unit
Ellipse (fitted)		
Ellipticity	92.19	%
Minor Ellipse Diameter (13.5%)	11.67	μm
Major Ellipse Diameter (13.5%)	12.66	μm
Mean Ellipse Diameter (13.5%)	12.17	μm
Eccentricity	38.73	%
Orientation	90.00	deg
Profile Measurement		
Beam Width Clip X (13.5%)	12.00	μm
Beam Width Clip Y (13.5%)	11.85	μm

7.2 Beam Quality (M^2) Measurement

The **Beam Quality** panel can be opened from the menu bar (Menu **Windows**) or by clicking the **M^2** icon in the tool bar.

7.2.1 General

The M^2 value is an important measure of the beam quality. It is widely used in the laser industry as a specification, and its method of measurement is defined in the ISO 11146 standard. It is particularly useful to describe the degree of divergence and the focusability (minimum focus diameter) of a real laser beam.

For more detailed information about Beam Quality, please see section [M² Theory](#)^[130].

Beam Quality

Beam Propagation measurements according to the standard **ISO 11146** describe the beam quality using a single parameter, which is either the **Times-Diffraction-Limit Factor M^2** or the **Beam quality $K = 1/M^2$** (also known as *beam quality factor* or *beam propagation factor*).

Whereas the beam quality K is directly proportional to the quality level ($K=1$ optimal, decreasing K stands for poorer quality), its reciprocal value M^2 ($M^2=1$ optimal, increasing M for poorer quality) is used more often.

Please do not confuse the beam quality ($K \leq 1$) and times-diffraction-limit factor ($M^2 = 1$).

Diffraction Limit

Depending on the wavelength λ and beam divergence angle θ , the theoretical limit for the minimum beam waist diameter d_0 is called the **diffraction limit**. The beam waist cannot be decreased beyond this value.

M^2 expresses how close the diffraction limit of the analyzed beam is to the diffraction limit of an ideal Gaussian beam. The beam parameter product $d_0 \cdot \theta$ describes that mathematically. For beams of less quality, the product $d_0 \cdot \theta$ is increased by the factor M^2 .

$$d_0 \rightarrow M^2 d_0$$

where d_0 is beam waist at the focus and θ - the divergence angle.

M^2 is also known as

- the ratio of the waist diameter d_0 of the measured beam to that of an ideal Gaussian beam (TEM_{00}) at the same divergence angle θ .
- the ratio of the divergence angle θ of the measured beam to that of an ideal Gaussian beam (TEM_{00}) at the same waist diameter d_0 ,

Lower beam quality results from laser imperfections like inhomogeneities which lead to appearance of higher transverse modes.

How to Measure Beam Quality

Ideal beam quality ($K=1$, $M^2=1$) with a diffraction limited waist size is possible if only the fundamental mode TEM_{00} (which has an ideal Gaussian shape) exists. The existence of higher modes decrease beam quality which leads to larger waist diameters. Often, such distortions can be easily discovered by looking at the non Gaussian beam profile.

But in many cases, several higher modes are distributed in a way that generate a nearly Gaussian shape but the beam itself suffers from a bad beam quality.

The following example shows a beam with nearly perfect Gaussian shape but having a multi-mode origin leading to bad quality $M^2 = 1.79$.

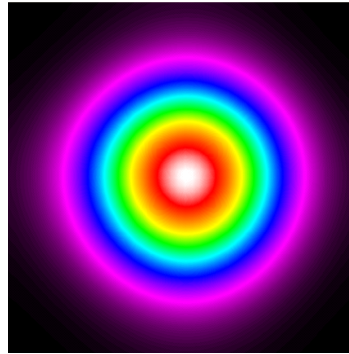

Note

A nearly Gaussian shape is not an indicator of high beam quality! Therefore, a single-shot beam shape measurement from a Beam Profiler does not provide a correct information about the beam quality.

Although a single Beam Profiler result is not a measure of beam quality, the Thorlabs Beam Profiler Series can be used to accurately measure the beam quality. For this purpose, a beam propagation measurement is carried out according to the ISO11146 standard. The key idea is to measure the variation of beam diameter $d(z)$ along the axis of beam propagation z .

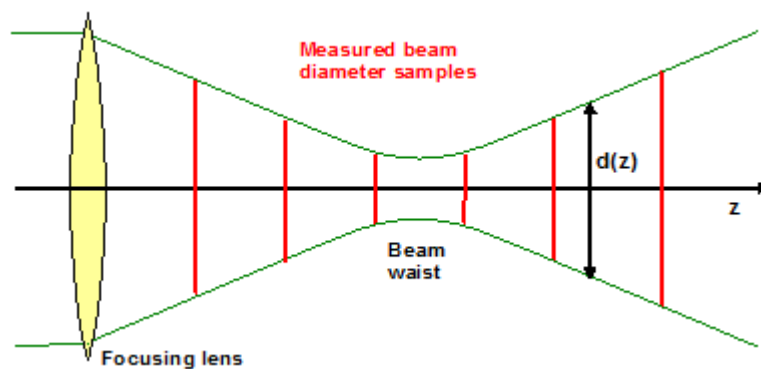

When used with the M2MS measurement extension, the beam diameter and other parameters are measured at several z -positions and stored by the software.

Besides learning the **times-diffraction-limit factor M^2** , the Thorlabs Beam Propagation measurement determines the following parameters of an optical beam:

- beam waist width d_{0x} , d_{0y}
- beam waist z -position z_{0x} , z_{0y}
- Rayleigh range z_{Rx} , z_{Ry}
- divergence angle θ_x , θ_y
- waist asymmetry
- divergence asymmetry

- astigmatism

Note

The Thorlabs Beam Quality measurement tool can handle CW sources and some pulsed sources! For more information about pulsed laser sources read chapter [Pulsed Laser Sources](#) ⁷².

7.2.2 M2MS Operating Principle

The Thorlabs M2MS M² Meter System is a compact instrument that includes all components required to measure beam quality:

- ① Beam Profiler (not shown below)
 - ② Linear Translation Stage Thorlabs DDS100
 - ③ Lenses with different AR coatings, suitable for different wavelengths to be analyzed
 - ④ Lens centering assembly (X-Y translation mount)
 - ⑤ 2 tilted mirrors
 - ⑥ Adjustment Laser (not shown below)
- Integrated control electronics (translation stage controller, USB 2.0 hub and driver for alignment laser)

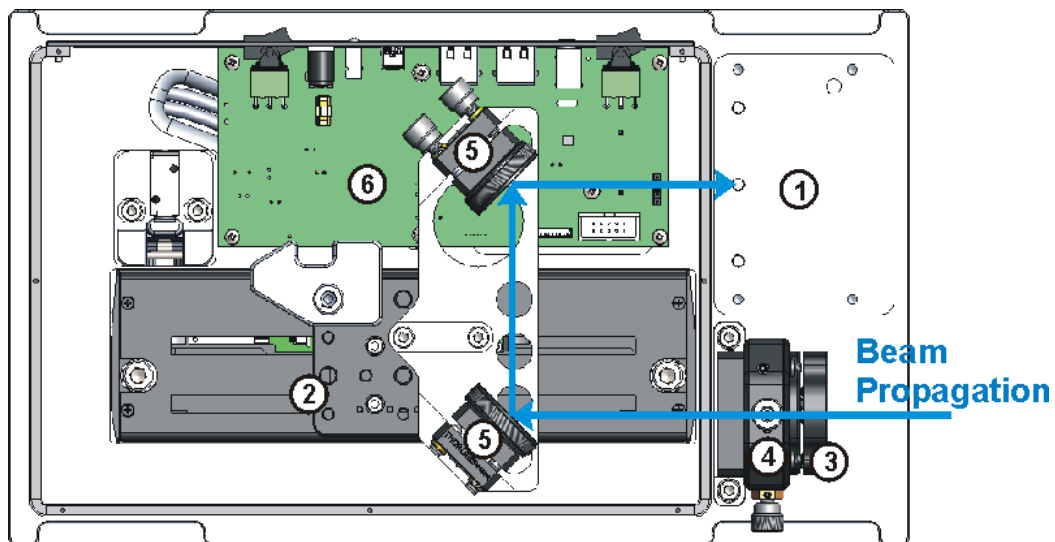

The beam under test enters the focal lens (3), hits the two tilted mirrors (5) and leaves the enclosure towards the Beam Profiler's input aperture (1). The translation stage is moved stepwise by the control software, and in this way changes the path length between the focal lens and the Beam Profiler. The maximum travel range of the stage (100 mm) is doubled by the use of two mirrors. The resulting path length range is 200 mm. The focal length of the lens is selected in such a way that the beam waist will be close to the middle of the travel range.

During the M² measurement, the stage moves stepwise along the beam propagation direction and at each position the beam geometry is measured. From the results, the software calculates beam parameters and beam quality.

The mirrors are factory aligned; there is no need to re-align them.

For fine beam alignment, an alignment laser is supplied. Please see section [Beam Alignment](#) ⁸⁸ for details.

7.2.3 Beam Diameter Requirements

The Beam Quality measurement is based on the determination of the waist diameter of a focused beam and the convergence (divergence) of the beam before (after) the beam waist.

Ideal Gaussian beams have the best focusability, which results in the minimum possible beam diameter and $M^2=1$. The absolute minimum waist diameter increases as the focal length of the lens increases. In other words, for a given focal length, the smaller the waist diameter the closer M^2 is to 1.

The minimum waist diameter increases (at a constant M^2) with the wavelength.

Limitations to the measurement of the beam diameter are given by the capabilities of the Beam Profiler, see [Technical Data](#)¹⁴⁵. The initial (unfocused) beam diameter must not exceed the maximum measurable beam diameter, the waist diameter must be greater than the minimum beam diameter. The following diagram illustrates the requirements for the initial beam diameter depending on the wavelength and for $M^2=1$ and $M^2=2$ (lens with a focal length of 250 mm as delivered with the M2MS system):

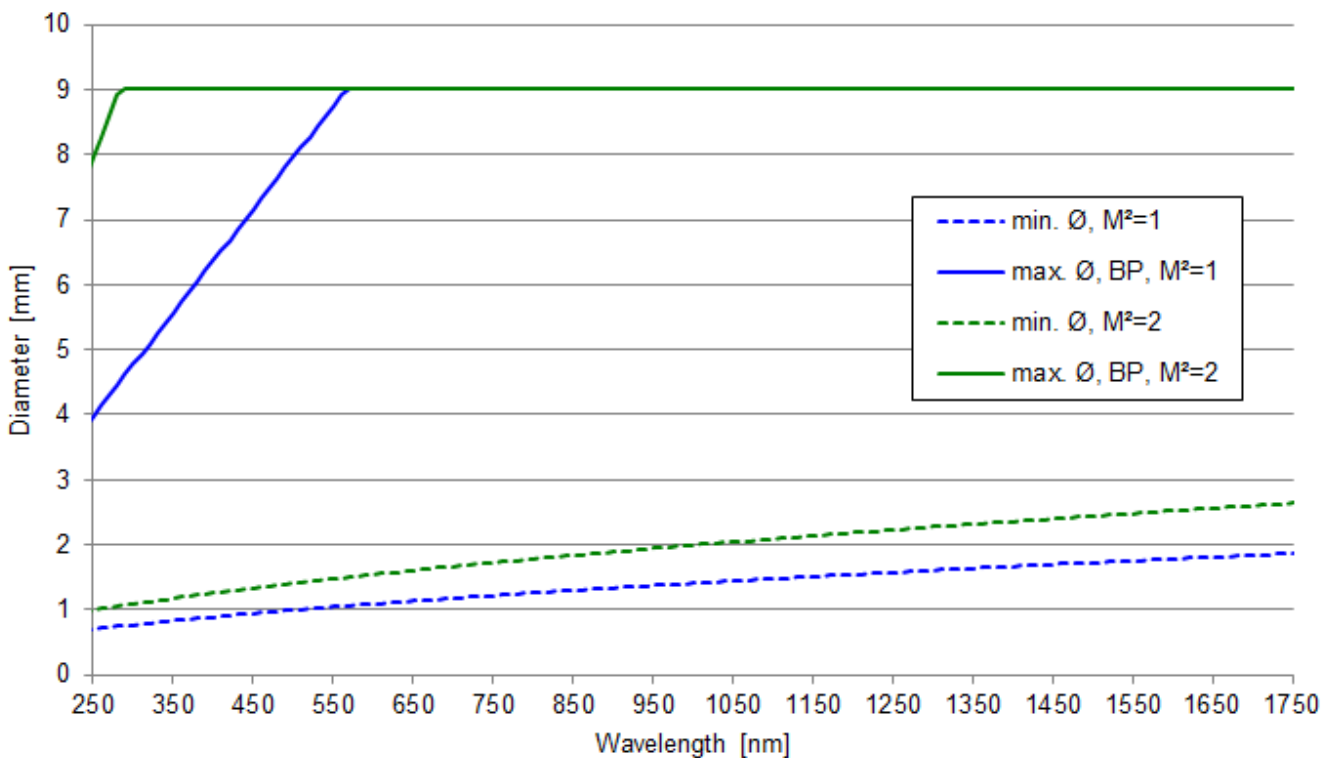

BP209 Series Beam Diameter Requirements

7.2.4 M² Meter Extension Set

The M² Meter Extension Set is an automated stage, compatible with all Thorlabs beam profilers of the BP209 and BC207 Series as well as the former BC106N Series, to scan through the light beam in the Z-axis for the beam profiler to acquire an M² value. Suitable mounting adapters for the beam profilers of the BC207 Series and BP209 Series are supplied. Please see the [M²MS website](#) for other adapters and information.

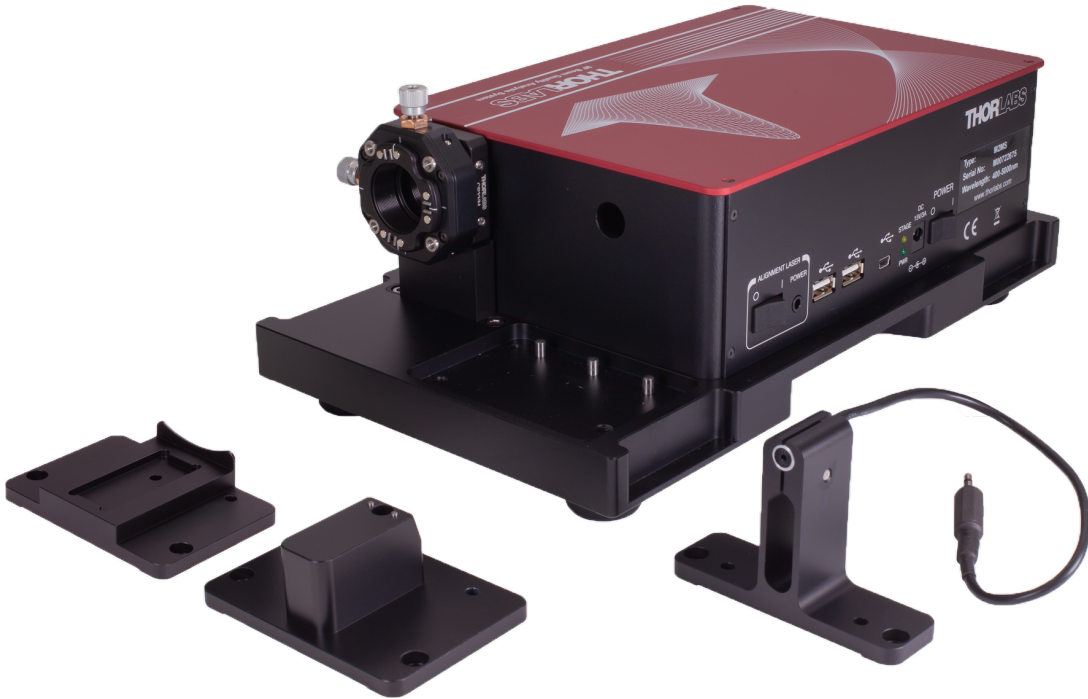

M²MS M² Measurement System Extension Set with adapters for BC207 Series and BP209 Series as well as the alignment laser.

7.2.5 M² Meter Set with BP209 Slit Beam Profiler

The M2MS-BP209 set features:

- Accurate M² Measurements
- Measures Divergence, Waist Diameter, Rayleigh Range and Astigmatism
- Compatible with CW and Quasi-CW Pulsed Laser Sources
- Short Measurement Cycles
- Fully ISO11146 Compliant

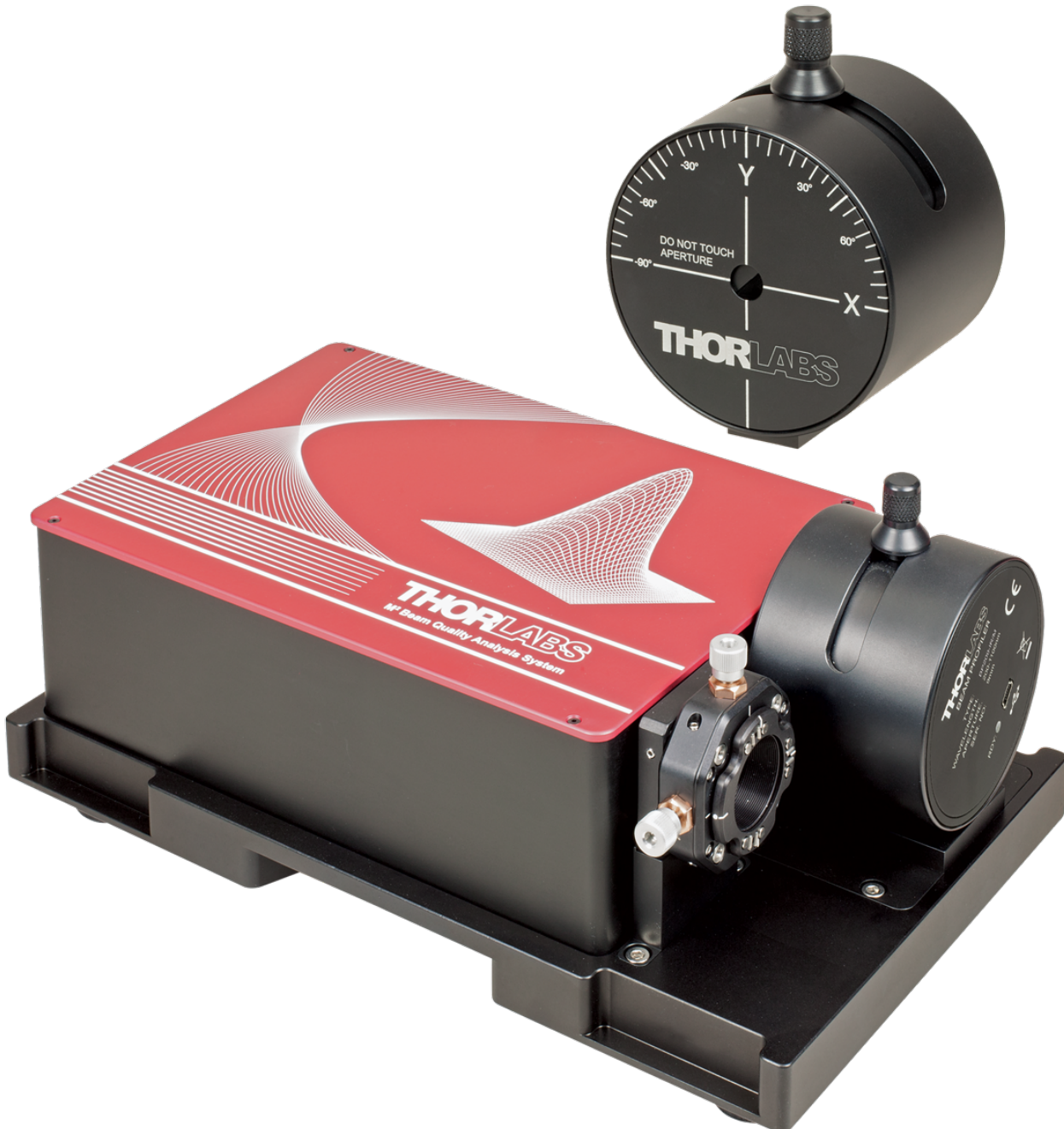

7.2.6 Setup M2MS

The M2MS Measurement System is factory aligned. The mounting adapter for the Beam Profiler provides a secure and reproducible positioning of the Beam Profiler's input aperture to the M2MS. This eases the mechanical setup.

Note

It is strongly recommended to fix the M2MS properly to the optical table using the four rail clamps that are included in the M2MS Accessory Box. To ensure proper mounting, first remove the rubber feet from the M2MS base plate.

Transportation Lock and Stop Position Latch

In order to avoid transportation damages to the translation stage, it is locked when delivered. This lock must be removed prior to powering-up the stage, and it must be re-installed for transportation. Additionally, the DDS100 stage is fixed at its initial position by a solenoid controlled latch, which is the left stop in the photo (2). This latch fixes the stage when the power supply is switched off and releases the stage when power is applied.

Removal of the Transportation Lock

1. Remove the 4 screws fixing the top cover using a 0.05" hex key (supplied with the M2MS) and remove the cover.
2. Remove the M4 screw that fixes the red stopper (1), and remove the stopper using the 3 mm ball driver included with the accessory box. Keep the stopper and the fixing screw in a safe place.

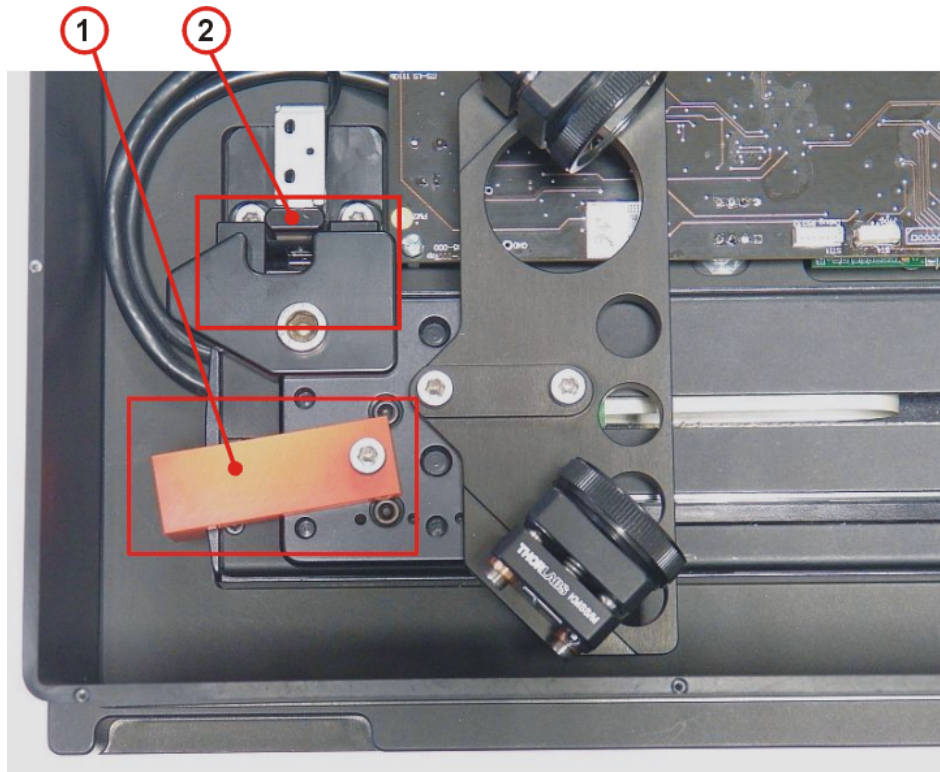

1 - Transportation Lock
2 - Electromagnetic Endpoint Latch

3. Close the M2MS.

Installing the Transportation Lock

1. Switch off the power supply.
2. Remove the 4 screws fixing the top cover using a 0.05" hex key (supplied with the M2MS) and remove the cover.
3. Move the stop latch as indicated in the picture below and place the platform of the stage against the left stop. Then install the transportation lock; do not tighten the fixing screw yet.

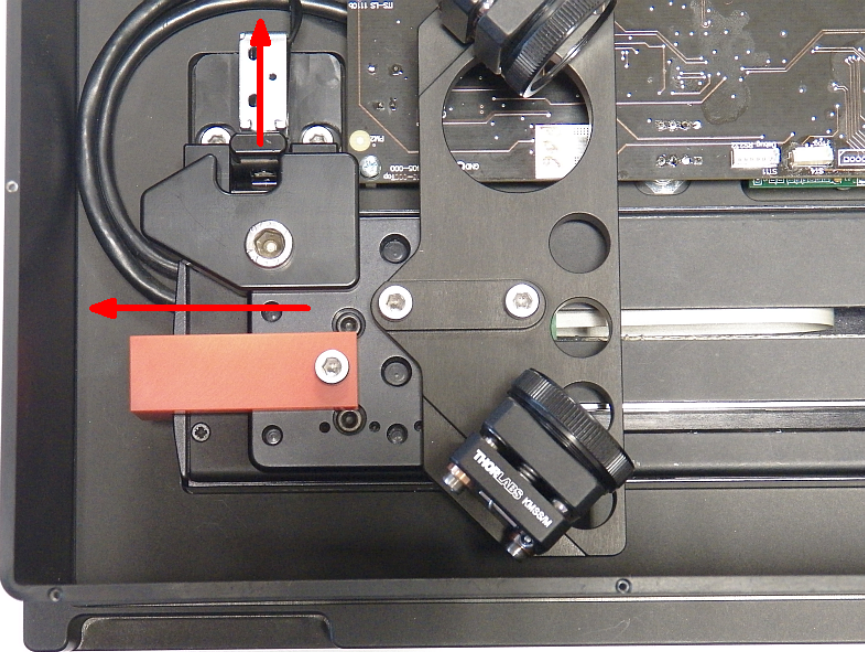

4. Push the platform to the left stop, turn the lock counterclockwise and tighten the lock screw.

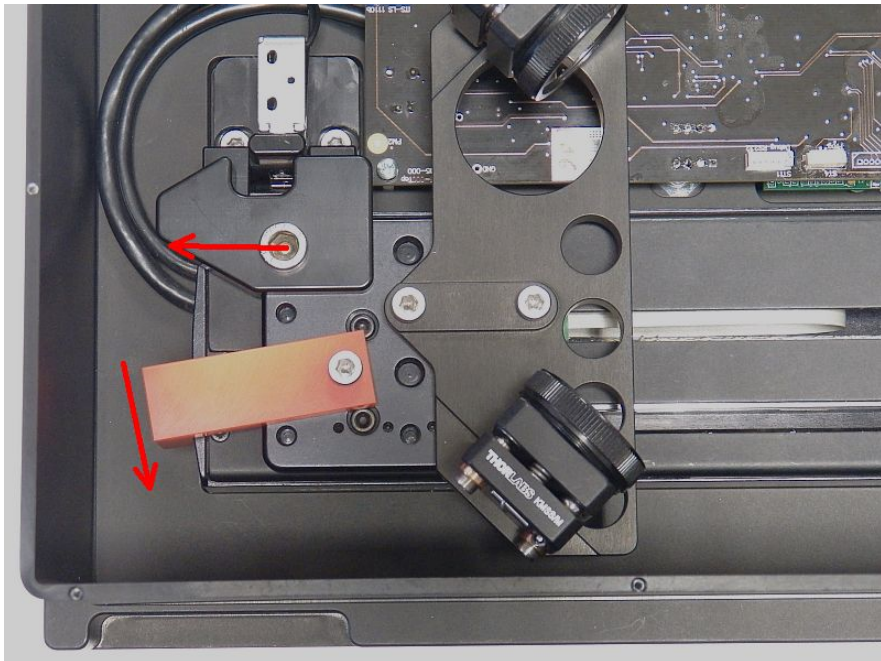

5. Place back the top cover and fix it using the 4 screws. Now, the M2MS is ready for transportation.

7.2.6.1 Mounting the Beam Profiler

Please mount your Beam Profiler as described here:

Install your beam profiler of the BP209 Series on the BP209 mounting adapter:



Firmly press the beam profiler front against the front stopper surface and secure it in place using the supplied M6 (metric systems) or 1/4" (imperial systems) hex screw.

Place the mounted Beam Profiler into the recess using the dowel pins on the M2MS base plate:



Fix it using the supplied M4x10 Hex screws.

7.2.6.2 Connecting M2MS to the PC

The M2MS comprises integrated control electronics with translation stage controller, a USB 2.0 hub and a current source for the alignment laser.

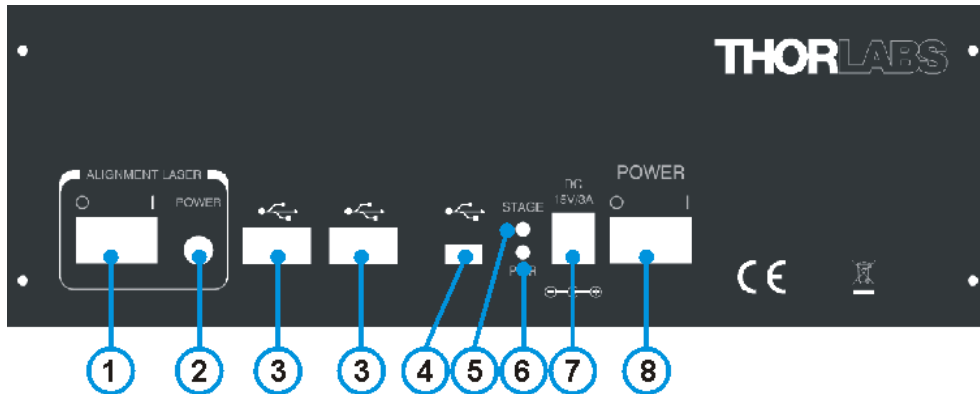

- ① Switch to enable Alignment Laser
- ② Output connector for Alignment Laser
- ③ USB 2.0 hub output ports (to Beam Profiler)
- ④ USB 2.0 input (from PC)
- ⑤ Yellow indicator "Stage active"
- ⑥ Green indicator "Power On"
- ⑦ DC power supply input
- ⑧ M2MS power switch

Attention!

Prior to connecting the M2MS to the power supply, make sure the [transportation lock is removed](#)! Otherwise the stage drive may be damaged!

Attention!

It is strongly recommended that only the supplied USB cables are used to connect the Beam Profiler and the control PC to the M2MS.

The use of other than the supplied USB cables may lead to USB connection instabilities.

Attention

Do NOT connect the M2MS to a computer prior to installing the Beam Software!

1. Remove the [transportation lock](#).
2. Connect AC power to the power supply and its output to the DC jack (Z).
3. When using a BP209 Series Slit Beam profiler, connect the beam profiler using the supplied angled USB 2.0 cable to one of the USB hub outputs (3).
4. Switch the M2MS on (8). The green **Power On** indicator lights up.
5. Connect the M2MS to the PC using the supplied 3 m long USB 2.0 cable; do not start the BEAM software yet.
6. The PC's operating system recognizes the connected new hardware and performs the driver installation:

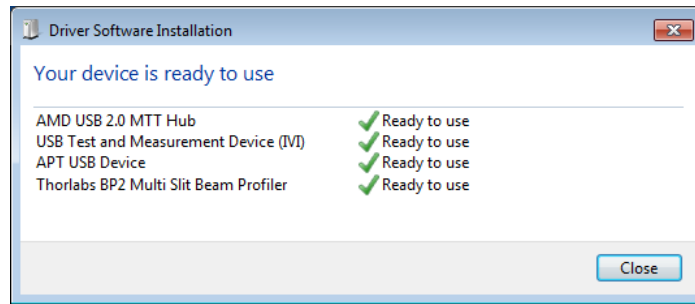

Note

The first three entries ("AMD USB2.0 MTT Hub", "USB Test and Measurement Device (IVI)" and the "APT USB Device") are hardware components of the M2MS extension.

7. Start the Beam Software. It should automatically connect to the Beam Profiler and to the translation stage. This can be seen in the Beam Settings Panel:

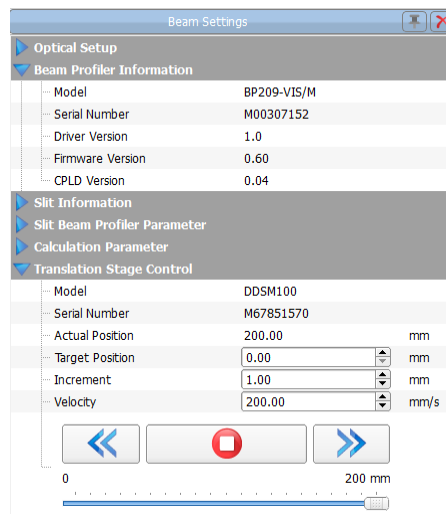

8. Upon starting the Thorlabs Beam Software, the translation stage will be initialized and homed automatically. This means that it is recognized in the tab **Stage Selection** and moves to the 200 mm position in case it is not there yet. This can take a few seconds. The initialization can be forced manually by clicking the "Refresh Stage List" button in the [Device Selection window](#)^[14]. After the stage is identified and its serial number is read from its EEPROM, double click the DDS100(/M) button in the device selection window.

7.2.7 M² Measurement

Prior to starting the Beam Quality measurements with the M2MS and a BP209 Series Beam Profiler, the beam of the laser under test needs to be aligned to the M2MS Measurement System. It is important that the beam center hits the center of the Beam Profiler's aperture at every position of the translation stage. Please read the following section carefully and follow the instructions.

Please open the M2 measurement panel via the icon **M²** to arrive at the alignment and measurement GUI.

To prepare for and perform a M2 measurement, please click the M² icon on the left side of the window. The top panel shows the [Alignment](#)^[88] tab, the [M² measurement](#)^[87] tab, and the [Live Adjustment](#)^[114] tab. Please start with the Alignment of your system.

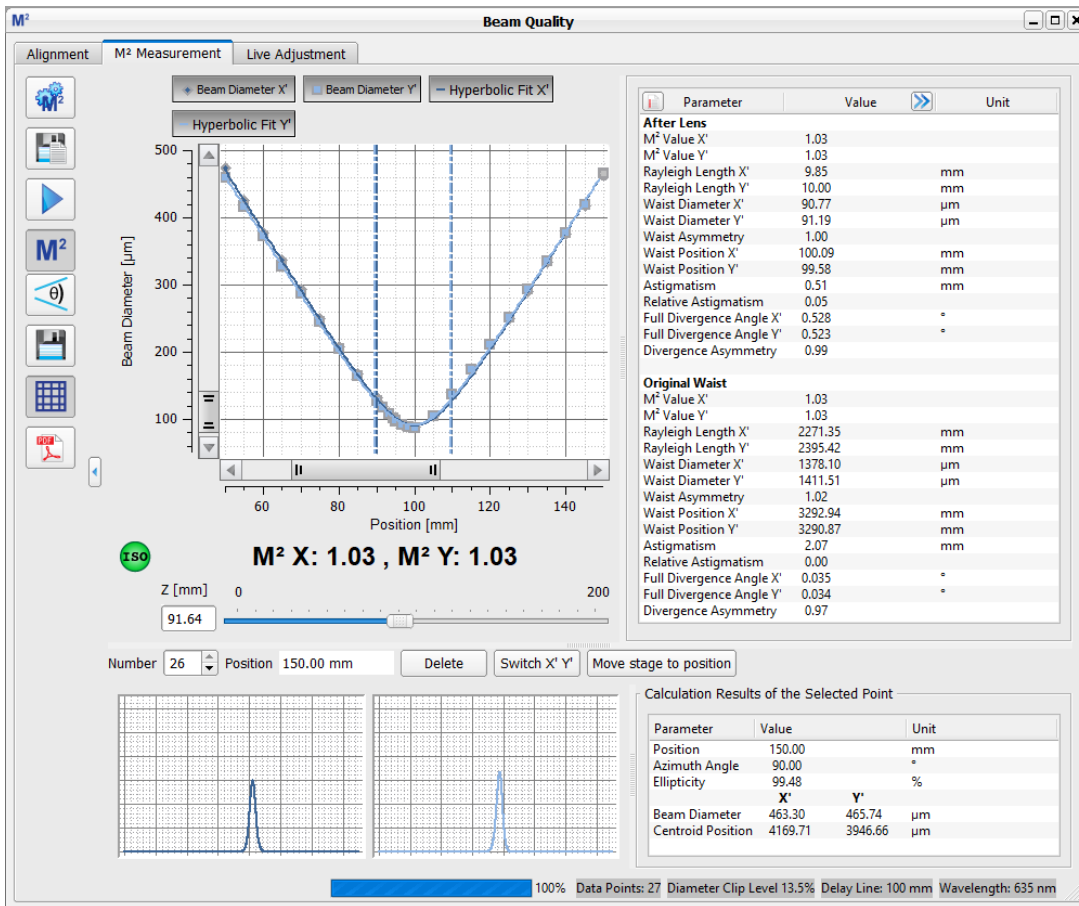

7.2.7.1 Beam Alignment

Why Beam Alignment?

The Beam Profiler has a defined input aperture, so when moving the translation stage it must be ensured that the laser beam remains within the aperture. Ideally, the beam centroid remains centered within the aperture during movement of the stage - this is a precondition for correct beam quality measurements.

All internal parts of the M2MS Measurement System are factory aligned. A beam entering the M2MS exactly parallel to the stage movement direction will remain centered to the Beam Profiler aperture during stage movement. In other words, the beam alignment is dependent only on the position of the light source. In the common case, the light source is a device with open beam output. In order to direct the beam under test into the M2MS, a combination of two adjustable mirrors is required, Thorlabs offers a variety of such items.

The beam alignment is executed in 3 steps, guided by a software wizard:

1. [Coarse Alignment](#)⁸⁹: Determine the correct location of the Laser Under Test output aperture by means of an auxiliary laser (included).
2. [Beam Alignment](#)⁹² of the Laser Under Test for minimum beam displacement and pointing angle without focusing lens.
3. [Alignment of the Focusing Lens](#)⁹⁶ for minimum beam displacement and pointing angle.

7.2.7.1.1 Coarse Alignment

For a coarse alignment, Thorlabs provides an alignment laser that is included with the accessory box. For this step, the alignment laser is mounted on the M2MS in place of the Beam Profiler as described below. It is mounted and aligned in such way that its output beam enters the M2MS exactly centered in the Beam Profiler's aperture and is parallel to the stage movement direction. The alignment beam is reverse directed - it virtually exits the Beam Profiler and is re-directed by the two mirrors of the stage into the center of the laser source aperture (see the drawing in section [M2MS Operating Principle](#)^[79]).

Warning Be careful when using the Alignment Laser!



- Remove the Beam Profiler together with its mounting adapter from the M2MS base.
- Install the adjustment laser in place of the Beam Profiler and connect its 3.5 mm plug to the [Alignment Laser output \(2\)](#)^[86].
- Make sure the M2MS is switched on and connected to the control PC, the Beam Software is started and the stage has been initialized.
- Remove the focal lens from the magnetic holder.
- Switch on the alignment laser.
- Align your optical system so that the spot of the alignment laser hits the center of your light source.

7.2.7.1.2 Fine Alignment







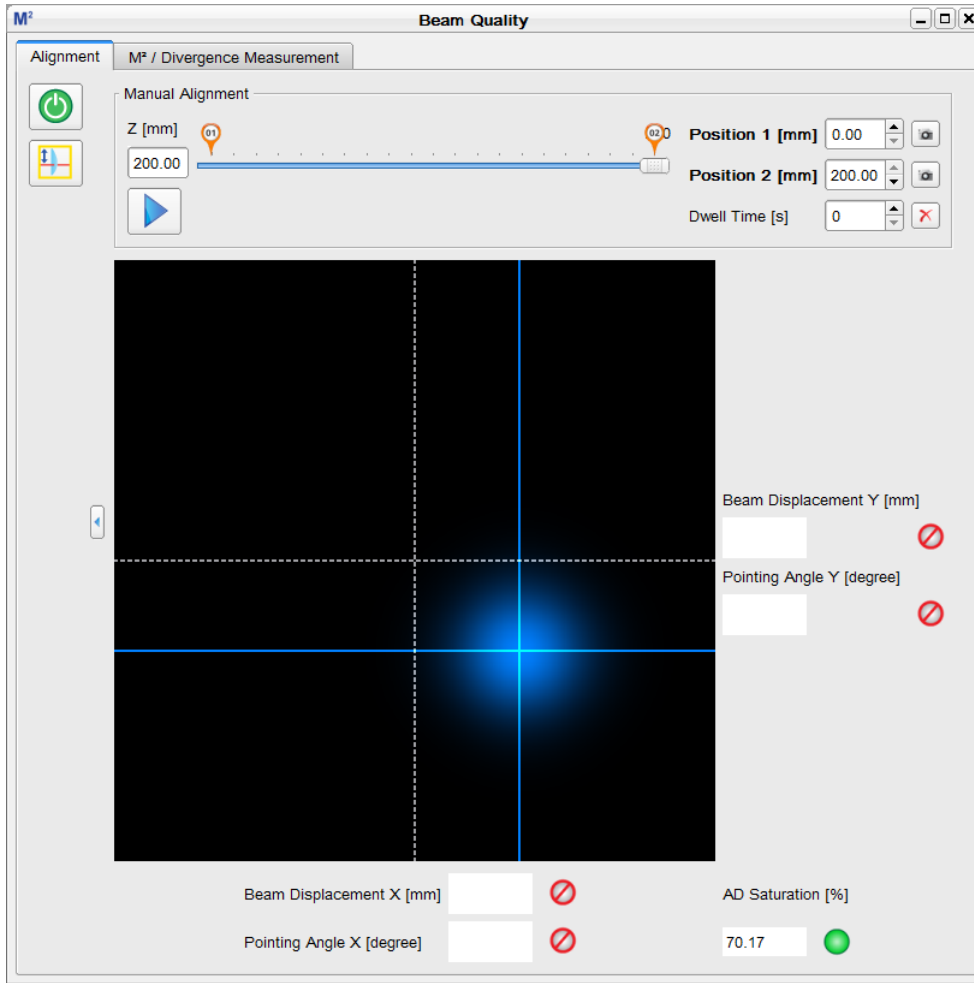





After coarse alignment, the beam under test needs to be fine-adjusted using the **Alignment** feature of the M² measurement panel. This is executed in two steps.

Preparation

- Switch off the alignment laser and replace it with your Beam Profiler.
- Make sure the BP209 beam profiler is connected to one of the M2MS USB 2.0 output ports (③, [Connection to the PC](#)^[86] section).
- Remove the focusing lens (see ③ in the drawing in the [M2MS Operating Principle](#)^[79] section).
- Make sure the BP209 Series beam profiler is recognized by the Beam Software (Toolbar  [Device Selection](#)^[87]). If it is not recognized automatically, press the **Refresh Device List**^[14] button.
- Make sure the stage is recognized and initialized. If not, press the [Refresh Stage List button](#)^[87] and after the stage was recognized, double click to the DDS100 button. The stage initializes and moves to the 200 mm position.
- Enable the Laser Under Test.
- Open M² child window either from the menu "Windows" -> "M² Quality Measurement" or by clicking the **M²** button, and switch to the Alignment tab.



Explanation of indicators and icons

	Start the Alignment Wizard 
	Start the Focusing Lens Alignment Wizard 
Z [mm]	This box shows the actual stage position; after initialization = 200 mm.
Position 1 (2) [mm]	The left and right positions for the stage movement can be entered numerically.
	Markers for left and right positions. Instead of numerical entry of the marker positions, the markers can be moved by drag-and-drop.
	When clicking these capture buttons, the stage moves to the related position, if not there yet, and captures the beam centroid position (amber crosshair). This snapshot will remain until the stage returns to the appropriate position.
	This button starts the stage loop movement mode and the stage moves continuously between positions 1 and 2. A dwell time at the end positions can be entered. During the loop mode, the software automatically captures the beam centroids (yellow cross hair) at the left and right stop.
Dwell Time	Enter the desired time [sec]. Disable the dwelling by clicking to the 
	Centroid crosshair of the actual beam position.
	Crosshair of the sensor center
Beam Displacement	Centroid shift in X (Y) direction between position 2 and 1 [mm]. The box is initially filled after the 2nd capture.
Pointing Angle	The angle [°] in X (Y) direction between the beam axis and the stage movement direction. The box is initially filled after the 2nd capture.
Alignment Success Indicator	 Alignment not successful  Alignment sufficient for correct Beam Quality Measurement (displacement < 0.65 mm, angle < 0.35°)  Good alignment (displacement < 0.35 mm, angle < 0.15°)
AD Saturation	Displays the current saturation of the Beam Profiler's AD converter. For proper beam alignment function the value must be 40 to 95 %. The green bulb to the right of the numeric field indicates the "GOOD" range.

Note

Make sure the rotation mount is oriented upright so that the Y axis of the BP209 Series is located vertically.

Press the **Start Wizard** button . You will be requested to select whether you want to adjust for M^2 or Divergence Measurement. Make your choice:

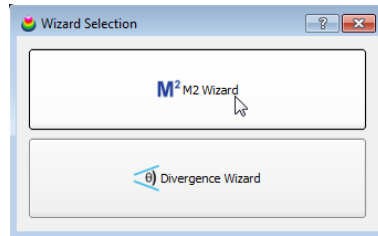

The wizard starts:

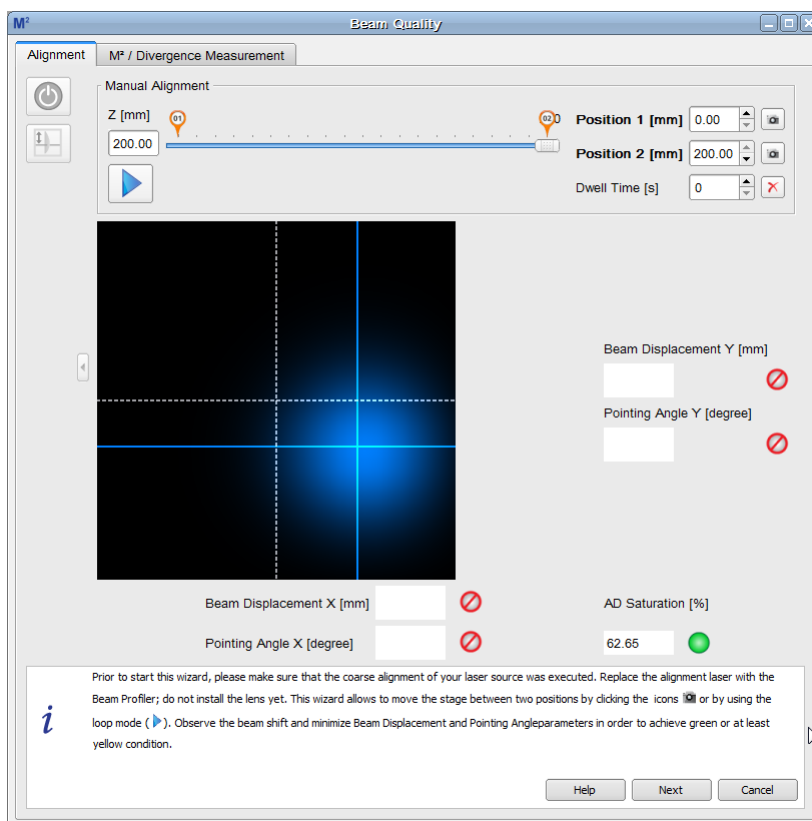

- For a successful alignment, the optical power level must be adjusted in such way that the AD Saturation is between 40 to 95 %. The green bulb to the right of the numeric field indicates the "GOOD" range. During alignment this condition must not change!
- After initialization, the stage is at Position 2 (200 mm). Click the capture button  of Position 2 - the centroid is captured, and its crosshair color changes to amber. As the actual beam centroid that is marked by a blue crosshair, is located at the same position, the resulting color is white:

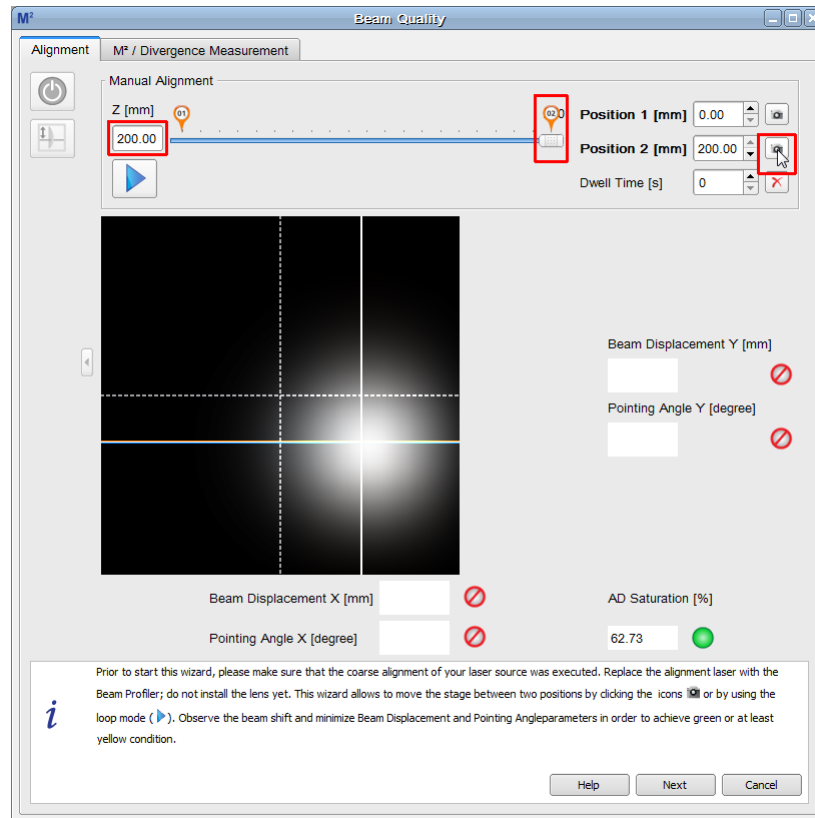

Centroid captured at Position 2

- Click to the Position 1 capture button (0 mm). The stage moves to Position 1 and captures the second centroid position:

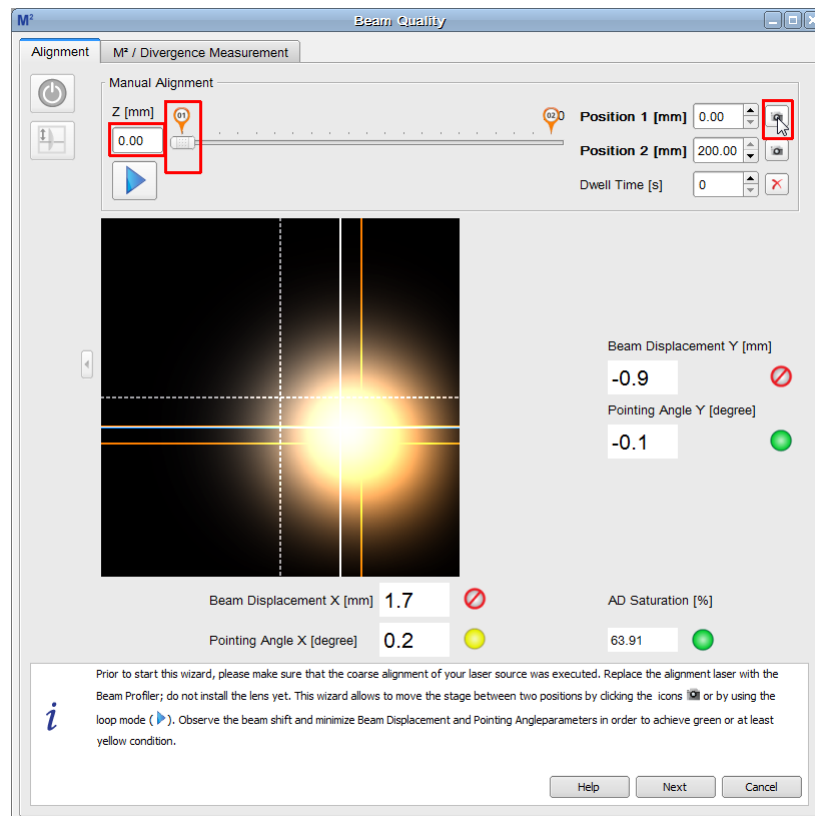

Centroid captured at Position 1

- Now, the beam displacement and the pointing angle are displayed numerically.

- Align the beam position using the controls of your laser source. Subsequently click the capture button of Position 1 and 2, observe the alignment, and improve it until all four alignment criteria are fulfilled (bulbs must be at least yellow):

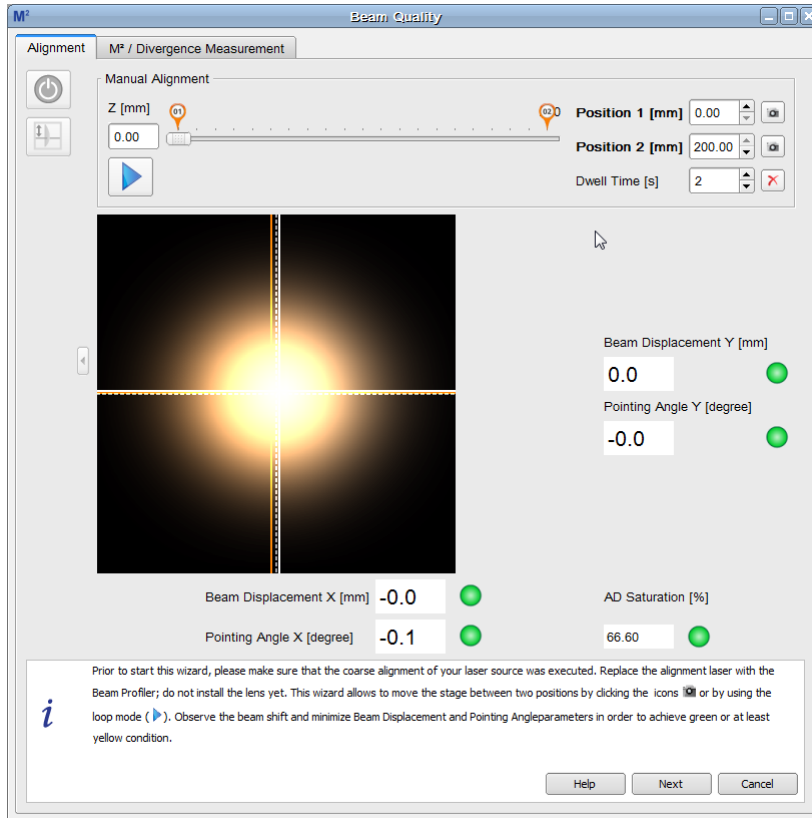

Well aligned beam position

- To toggle between the two positions, the movement of the stage between the two stop positions can be controlled automatically by the software. Just push the loop button  and enter a convenient dwell time value. The stage starts a loop move, dwelling at the stop position for the given time. During the dwelling a realignment can be made. Please keep in mind, that the numeric alignment indicators are being updated only after the next move.

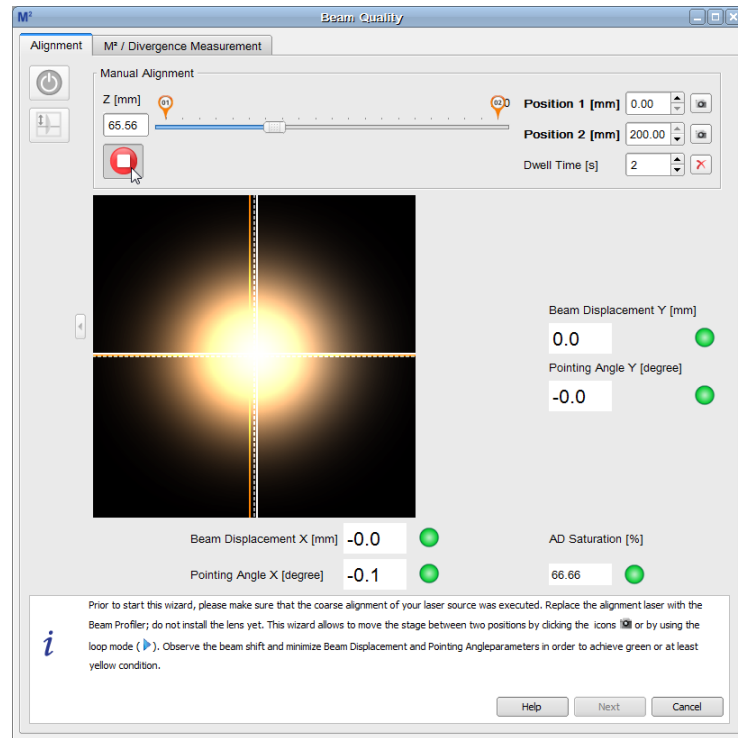

Alignment Move Loop

- To terminate the loop, click the  button.
- After finishing, click **Next** to continue.

- After finishing the Beam Alignment, the wizard guides you to the alignment of the focusing lens. As a first step, capture the beam position without lens, then click "Next":

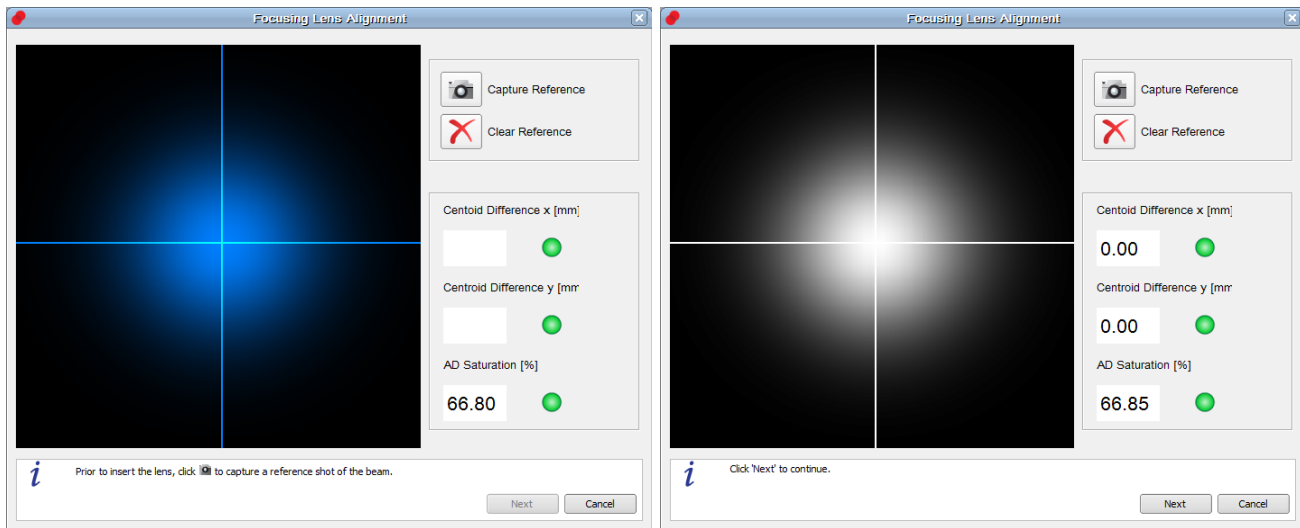

- Verify that the holder of the focal lens is centered (markers on the CXY1 translator and the lens holder should match), place the the mounted focal lens back to the magnetic holder.
 - Make sure that the bullet next to the AD Saturation is still in green or at least yellow.
 - Observe the actual beam position and minimize the difference to the reference, using the X-Y translators of the lens holder until the indicators are green or at least yellow.

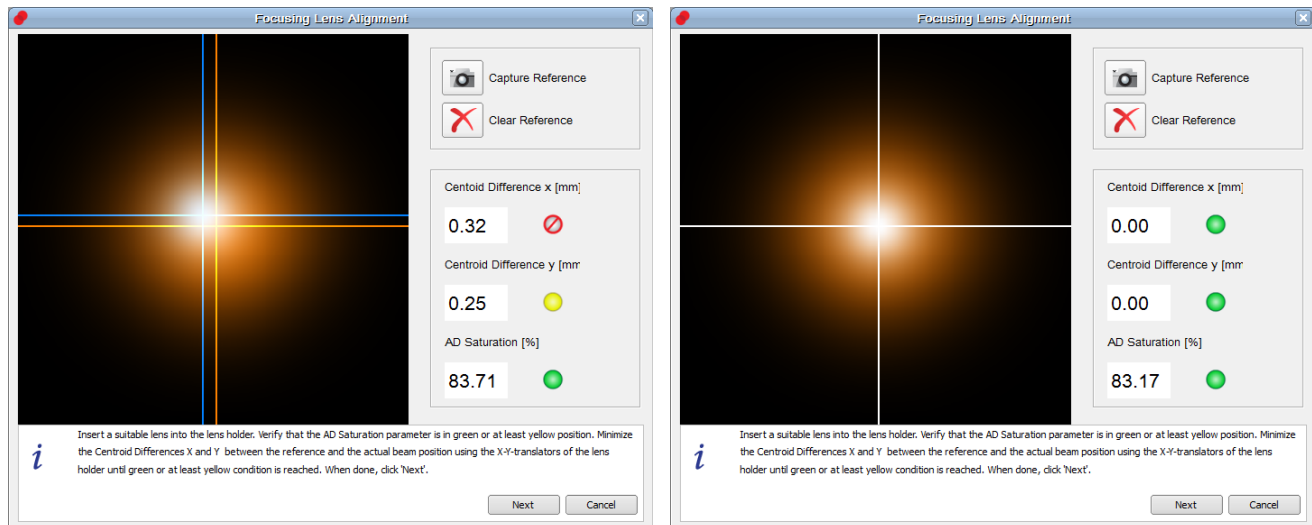

- Then click "Next" to finish the Focusing Lens Alignment.
- Select if you want to continue with an M² measurement:

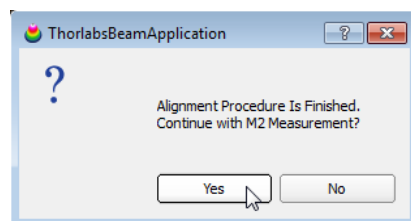





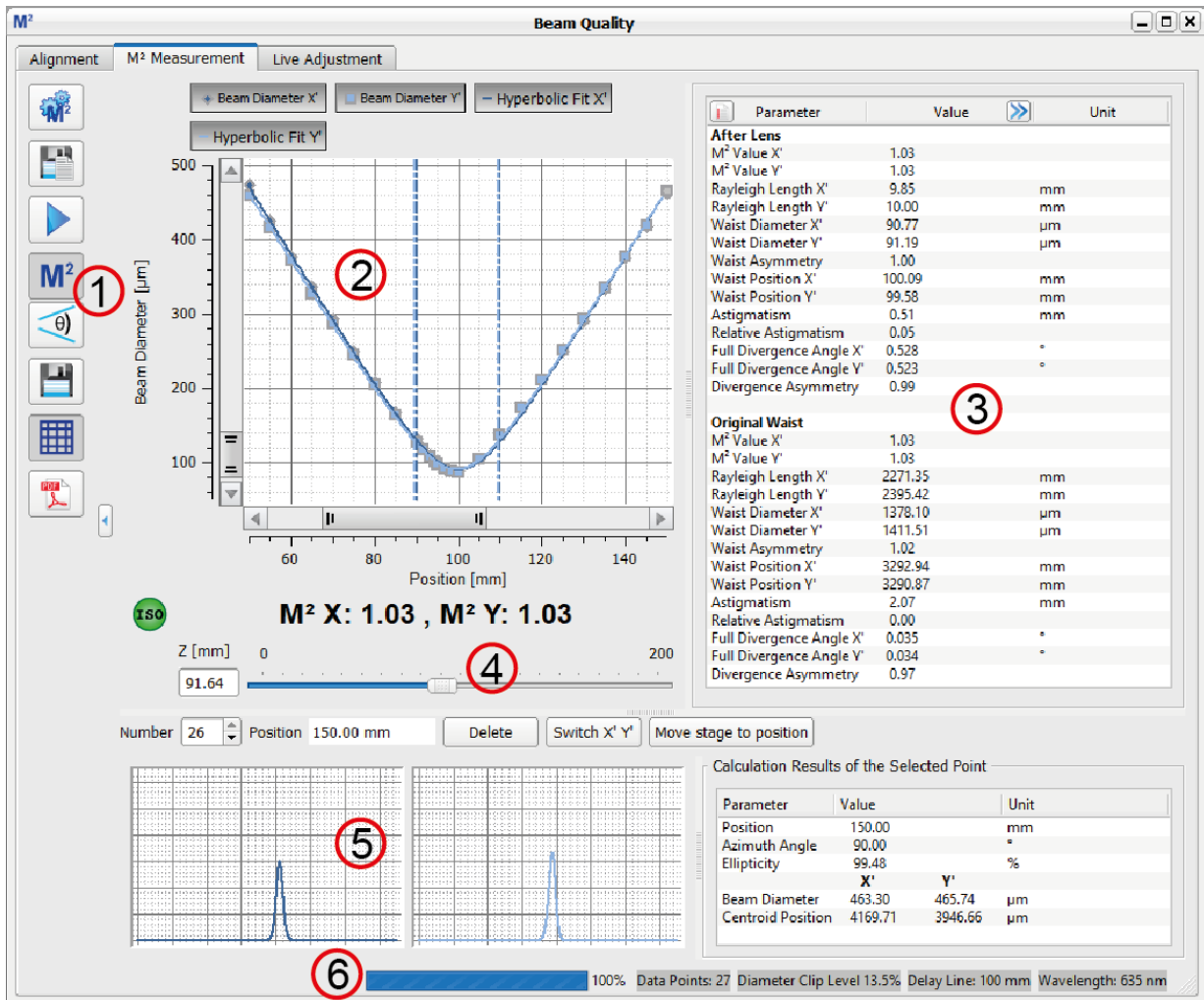



7.2.7.2 M² Measurement Panel

This section concerns the M² measurement and its settings. Click "M2 Measurement" in the **Beam Quality Measurement** window to enter the M² Measurement section.



The M² panel is divided into 6 subpanels:

1. Toolbar

-  M² Settings Opens the [Settings](#)⁹⁹ for the M² measurement
-  Auto Save Data [Save Beam Profile Data during M² Measurement](#)¹⁰³
-  Start / Stop Starts / stops a M² measurement
-  M² Switches to M² measurement
-  Divergence Switches to θ Divergence measurement
-  Save Data After a successful M² measurement this button is enabled and plot data can be saved.
-  Grid Disables/Enables the grid in the diagram
-  PDF Test Protocol Saves the results of a M² measurement into a PDF file

2. M² Diagram

The measured data are plotted in the diagram. The 4 buttons above the diagram allow the display to be configured:

- The buttons **Beam Diameter X' (Y')** enable / disable the display of the measured data at the individual positions
- The buttons **Hyperbolic Fit X' (Y')** enable / disable the curve fit to the measured data points.

Following the measurement, the results for the X and Y axes are displayed. To the left, an indicator shows if the measurement was successful and ISO compliant. See also section [M² Troubleshooting](#) ¹¹¹.

The button  between the toolbar and the diagram expands the diagram over the entire M² window.

3. Numeric Results

In this area, the Beam Quality measurement results are displayed in detail. Please see section [M² Measurement Results](#) ¹⁰⁶ for more details. The displayed parameters can be configured through the icon in the upper left corner of subpanel 3.

4. Position Bar

The Position Bar below the M² Diagram shows the actual position of the translation stage as seen before in the **Alignment** tab.

5. Selected Data Points

Select in the header of this sub-panel the **Number** of the desired measured data point. For this selected point, the position of stage and the profile in X and Y of the beam is displayed. The table **Calculation Results of the Selected Point** to the right contains the following information:

Parameter	Explanation
Position	Shows the actual Z position of the translation stage in mm.
Azimuth Angle [deg]	The displayed value is not relevant, it is always equal to 0°.
Ellipticity	The ellipticity of the fitted to an ellipse beam (see Application Note ¹⁴²)
Beam Diameter X' [μm] Beam Diameter Y' [μm]	Depending on the settings ⁹⁹ , the beam diameter is displayed based on Gauss fit, approximated ellipse or Beam Width Clip (1/e ²). The coordinate system is always related to the slit coordinates as marked on the front panel of the Beam Profiler.
Centroid Position X' Centroid Position Y'	The positions of the beam centroids related to the slit coordinates as marked on the front panel of the Beam Profiler.

6. Status Bar

- Measurement progress bar
- Total number of measured data points
- Beam width setting for M² measurement
- Delay Line: Measurement range (difference between Start and Stop positions)
- Wavelength setting for beam quality calculation

7.2.7.3 M² Settings

For a successful and reliable measurement, the appropriate measurement settings are essential. Click  to enter the **M² Measurement Settings** dialog.

Beam Width

Gaussian Diameter: The beam profile will be fit using a Gaussian curve prior to the determination of the beam width. A Gaussian fit can reduce the impact of noise and/or unstable beam shape on the results.

Beam Width Clip (1/e²): This is the value specified in ISO standard 11146-3. If a different clip level was used for normal Beam Profiler operation this will be overwritten by the M² measurement initialization.

Correct Beam Width: This option should be activated by default. Due to the finite slit width so called convolution errors (blurred beam shape) appear, particularly at small beam diameters, that results in an artificial increase of the beam width. Since this convolution error is systematic it can be calculated and eliminated. This feature increases the measurement accuracy, particularly when measuring narrow beams.

Measurement Parameters

Setting the wavelength is mandatory for a correct M² measurement. If the lasing wavelength is un-

known, measure the wavelength using a spectrometer.

Attention

Do not use the nominal wavelength of the laser, use the actual (measured) value! Accuracy of this input significantly impacts the measurement accuracy.

Measurement Range

The **Measurement Range** determines the distance between the Start and Stop position, in other words, the travel distance of the sleigh during the measurement. The travel distance can range from 5 mm to the full length of the stage.

Min. Data Points is the (minimum) number of Z positions at which measurements will be made.. The actual number depends also on the **Scan Method**.

Timeout is the waiting time until valid data can be retrieved from the Beam Profiler (e.g. in case of slow travel speed).

Scan Method

The software provides two different kinds of scan methods, the **Normal Scan** and the **Coarse Scan**.

The **Coarse Scan** just moves the translation stage from **Start** to **Stop** positions (or vice versa depending on the position prior to start the measurement). The number of recorded beam widths equates exactly to the entered number of **Data Points**.

The **Normal Scan** pursues an ISO compliant measurements. The ISO standard requires that **"... at least 10 measurements shall be taken. Approximately half of the measurements shall be distributed within one Rayleigh Length on either side of the beam waist, and approximately half of them shall be distributed beyond two Rayleigh Lengths from the beam waist."**

The first run of the Normal Scan is executed with respect to the entered number of **Data Points**, in other words, like a coarse scan. A preliminary Rayleigh Length is calculated in order to evaluate if the number of measured data points is sufficient to fulfill the ISO standard requirements. If so, a hyperbolic fit is applied. If not, a second run adds additional measurements within the Rayleigh Length on both sides and/or beyond twice the Rayleigh Length.

For a M^2 measurement, running the Normal Scan is highly advised. The coarse scan is suitable for a first estimate of the beam waist position or other preliminary measurements.

Reset



Restores the default settings for M^2 settings:

Parameter	Default Setting
Beam Width	Beam Width Clip ($1/e^2$)
Wavelength	635 nm
Timeout	15 sec
Start	0 mm
Stop	200 mm
Min. Data Points	10
Scan Method	Normal Scan

Device Settings

It is important to set Gain and Base Line Correction of the Beam Profiler to Auto; Bandwidth to 125 kHz (see [Slit Beam Profiler Parameter](#)³¹).

7.2.7.4 Saving the M² Measurement Results

Besides the standard function "[Save M² Test Results](#)"¹⁰¹ the Thorlabs Beam Software offers an [automatic saving of beam profile data](#)"¹⁰³ when an M² measurement is executed.

7.2.7.4.1 Saving M² Test Results

The beam quality measurement results can be saved in two different ways:

1. Save Test Results

 Save measurement data as CSV (default). The [Save Test Protocol](#)"⁷⁰ dialog opens, select the desired path, file name and file format (csv, txt or xls), fill in the desired fields and click Save. Below is an example:

```

Thorlabs Beam M2 Data Export

Date MM-DD-YYYY;11-26-2021
Time HH:MM:SS;10:54:00

Beam Profiler
Model;BP209-VIS/M
Serial Number;E13100001
Profiler Azimuth Angle ;[deg];
Wavelength;[nm];635
Resolution;[μm];1.2
Beam Quality Measurement;M2
Beam Diameter Measure Method;Beam Width Clip (1/e2)

* * * * *
After Lens Measurement Results
* * * * *
Parameter;Unit;Result;
M2x'; ;1.04;
M2y'; ;1.02;
Rayleigh Length X';mm;9.87;
Rayleigh Length Y';mm;9.93;
Beam Waist Diameter X';μm;90.95;
Beam Waist Diameter Y';μm;90.62;
Beam Waist Asymmetrie; ;1.00;
Beam Waist Position X';mm;100.03;
Beam Waist Position Y';mm;99.53;
Astigmatism;mm;0.50;
Relative Astigmatism; ;0.05;
Divergence Angle X';deg;0.528;
Divergence Angle Y';deg;0.523;
Divergence Asymmetry;%;0.990;

* * * * *
Original Waist Measurement Results
* * * * *
Parameter;Unit;Result;
M2x'; ;1.04;
M2y'; ;1.02;
Rayleigh Length X';mm;2285.08;
Rayleigh Length Y';mm;2402.58;
Beam Waist Diameter X';μm;1384.02;
Beam Waist Diameter Y';μm;1409.73;
Beam Waist Asymmetrie; ;1.02;
Beam Waist Position X';mm;3293.34;
Beam Waist Position Y';mm;3310.23;
Astigmatism;mm;16.89;
Relative Astigmatism; ;0.01;
Divergence Angle X';deg;0.035;

* * * * *
BEAM DIAMETERS
* * * * *
Z;X';Y';
50.00;471.15;459.40;
55.00;425.52;416.97;
60.00;380.29;368.98;
65.00;335.77;328.49;
70.00;291.98;286.33;
75.00;251.01;246.20;
80.00;209.62;205.21;
85.00;167.97;164.72;
90.00;131.09;126.84;
91.56;119.92;117.03;
93.26;109.48;106.03;
94.45;102.75;99.88;
94.96;99.77;98.60;
95.00;99.76;98.54;
96.66;92.50;90.40;
98.36;88.47;88.12;
100.00;88.32;87.39;
105.00;105.29;104.62;
110.00;135.69;136.43;
115.00;171.95;173.59;
120.00;211.35;212.34;
125.00;250.96;252.08;
130.00;291.89;292.67;
135.00;333.19;336.36;
140.00;373.92;378.09;
145.00;419.07;421.80;
150.00;467.34;466.33;

```

2. Save Test Protocol

 Save measurement data as *.pdf file. The [Save Test Protocol](#) dialog opens, fill in the desired fields and click Save. The M² Measurement Results will appear in the PDF documents.

M² Test Protocol

General Information: The test has been performed in accordance with ISO 11146.

Date (MM-DD-YYYY): 11-26-2021 Time: 11:18:13

Information Concerning Testing and Evaluation:

Thorlabs Beam, Version 8.1.5190.321

Measurement Method:	Clip Level at 1/e ²	Model:	BP209-VIS/M
Serial Number:	E13100001	Profiler Azimuth Angle:	
Wavelength:	635 nm	Scan Range:	50.00 - 150.00 mm
Min. Data Points:	20		

After Lens Results:

Parameter:	Result:	Unit:
M ² Value X'	1.03	
M ² Value Y'	1.03	
Rayleigh Length X'	9.82	mm
Rayleigh Length Y'	9.94	mm
Waist Diameter X'	90.50	µm
Waist Diameter Y'	90.79	µm
Waist Asymmetry	1.00	
Waist Position X'	100.09	µm
Waist Position Y'	99.53	µm
Astigmatism	0.56	mm
Relative Astigmatism	0.06	
Full Divergence Angle X'	0.53	°
Full Divergence Angle Y'	0.52	°
Divergence Asymmetry	0.99	

Original Waist Results:

Parameter:	Result:	Unit:
M ² Value X'	1.03	
M ² Value Y'	1.03	
Rayleigh Length X'	2268.76	mm
Rayleigh Length Y'	2403.28	mm
Waist Diameter X'	1375.60	µm
Waist Diameter Y'	1412.14	µm
Waist Asymmetry	1.03	
Waist Position X'	3300.25	µm
Waist Position Y'	3308.48	µm
Astigmatism	8.23	mm
Relative Astigmatism	0.00	
Full Divergence Angle X'	0.03	°
Full Divergence Angle Y'	0.03	°
Divergence Asymmetry	0.97	

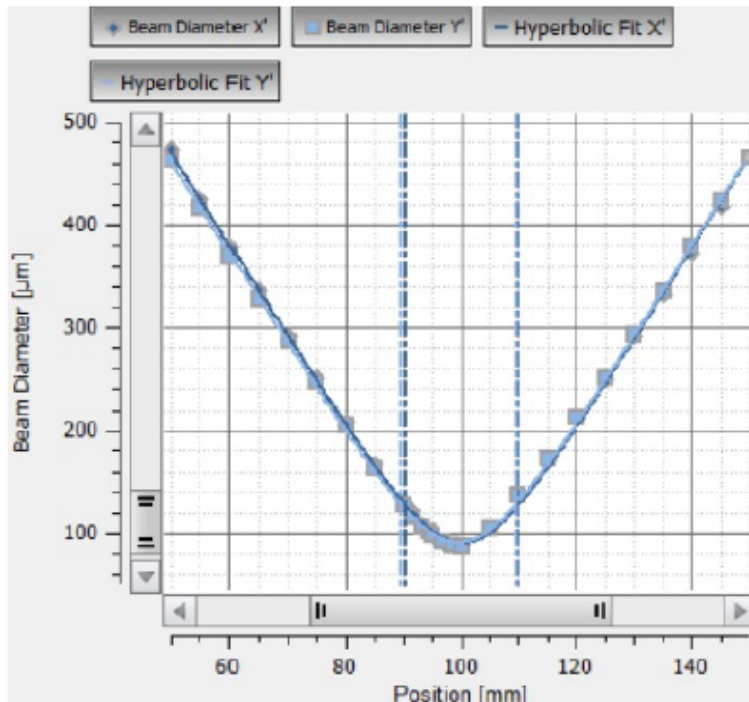

7.2.7.4.2 Saving Beam Profile Data During M² Measurement

During an M² measurement, the beam profile calculation results, the device data and the M² measurement results can be saved automatically at each position of the translation stage.

To configure this automatic data export click the  icon in toolbar on the left side of the M² panel. A dialog opens:

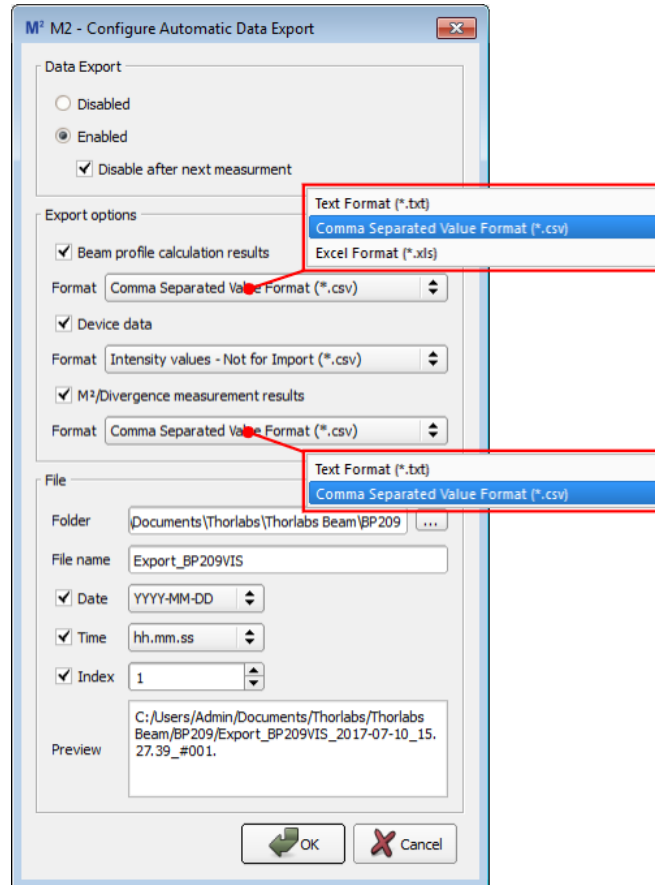

Section Data Export

Select **Enable** to activate the automatic export. The toolbar icon changes to  and the status bar on the bottom of the GUI appears as

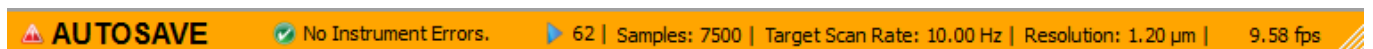

The Data Export remains active until **Disable** is checked. If the data shall be saved only once, please check the boxes

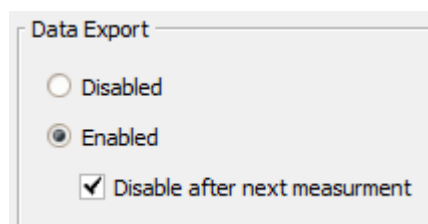

Select **Disable after next measurement** to stop the automatic export after the first run of the M² measurement.

Section Export Options

Here the data to be exported can be selected by checking the appropriate box.

Beam Profile Calculation Results can be saved as .csv, *.txt, or *.xls files. A single file is saved; for each stage position the data are appended to the existing file. The export file contains the header (information about Beam Software version, time stamp of measurement start, and information about the used beam profiler) and all calculation results (see section [Calculation Results](#)⁴⁵; option "Select All"). The name of this file is formed by appending the string "data" to the base file name.

With **Device Data** enabled, at each stage position the intensity values that are retrieved from the beam profiler are saved to an individual file. For device data and file formats, please see section [Export Device Data](#)⁶⁷. The name of this file is formed by appending the string "device" to the base file name.



When **M² / Divergence Measurement Results** is enabled, the M² test results are saved in *.txt or *.csv format as well; see section [Saving M² Test Results](#)¹⁰¹.

Section File

- Select the desired target file folder for the automatic data export.
- Choose a file name.
- Add the date (optional)
- Add the time stamp (optional)
- Add an index (optional). The index must be set manually!
- The box Preview shows the prefix of the file name with selected options.

When done, click **OK**. Now, the M² measurement with automatic data export can be started.

File Naming with Automatic Data Export

Beam Profile Calculation Results	
 Export_BP209VIS_2017-07-10_15.29.12_#001_Data.csv	
prefix with date, time and manual index	"Data" stands for Beam Profile Calculation Results
Device Data	
 Export_BP209VIS_2017-07-10_15.29.12_#001_Device_2017-07-10_15.29.22_#001.csv	
prefix with date, time and manual index	"Device" stands for Exported Device Data (here:intensity values of the beam). Followed by individual time stamp and automatic index of the appropriate stage position
M² / Divergence Measurement Results	
 Export_BP209VIS_2017-07-10_15.29.12_#001_Results.csv	
prefix with date, time and manual index	"Results" stands for M ² test results

7.2.7.5 Running the M² Measurement

Prior to starting a measurement, make sure that the following conditions are fulfilled:

- The beam is aligned properly - it should ideally remain centered with respect to the sensor center over the entire scan range. Section [Beam Alignment](#)^[88] describes in detail how to achieve this.
- The beam diameter should be in accordance with the [Requirements to Beam Diameter](#)^[80].
- The exact wavelength of the laser under test is well known, as the wavelength value influences the M² results.
- Reflections and interferences are avoided as far as possible.
- The laser system is warmed up - depending on the source this might take up to 1 hour.
- The laser output is spatially and temporally stable.

Start the measurement by clicking the **Start** button . You will be prompted to confirm the laser wavelength:

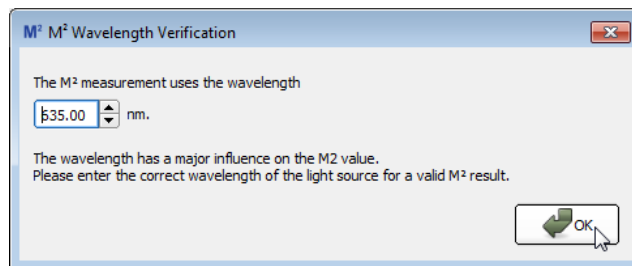

Verify the wavelength and click **OK**.

While running the measurement most of the buttons and options are disabled, e.g. the M² Measurement Settings and the Toolbar. This is intentional and prevents any settings changes during the measurement.

The measurement can be interrupted at any time by clicking the **Stop** button .

After starting the measurement the X axis of the graph is adapted to the user-defined scan range, for example from 50 to 125 mm. The Y axis scales automatically to the recorded beam width.

If the **Normal Scan** is applied the scale on the graph zooms in when the fine scanning adds additional data points. After this step (at the end of the measurement) the full scan range is shown again.

7.2.7.6 M² Measurement Results

After a successful M² measurement, the **Beam Quality Measurement** window shown below appears.

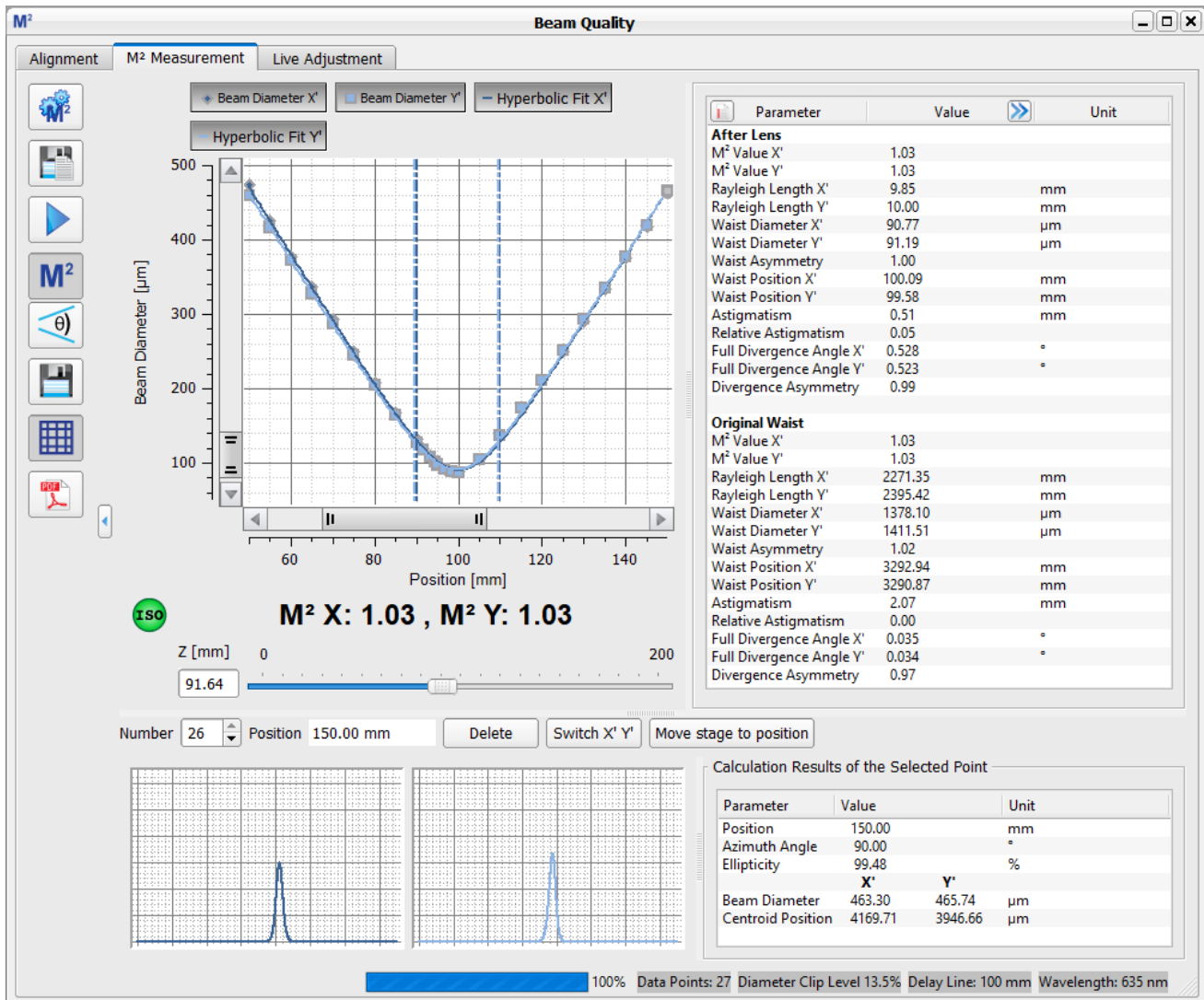

The green bulb indicates that the measurement was successful and fulfills the ISO 11146 standards:

ISO M² X: 1.03, M² Y: 1.03

In the case that beam criteria different from the ISO standard beam width criteria were used (see [M² Settings](#) ⁹⁹), a successful measurement is shown without the ISO indication:

M² X: 1.10, M² Y: 1.07

In general, the X' and Y' axes do not coincide with the lab system (described by the X and Y axes). Furthermore, the M² value for X' is independent from the one for Y'. For highly elliptical beams, such as those from semiconductor lasers, M²X' and M²Y' will differ much more than in this example.

Diagram Legend

- ◆ Beam Diameter X'
- Beam Diameter Y'
- Hyperbolic Fit X'

Hyperbolic Fit Y'

These values can also be found in the listing of the complete results next to the diagram:

Parameter	Value	Unit
After Lens		
M ² Value X'	1.03	
M ² Value Y'	1.03	
Rayleigh Length X'	9.85	mm
Rayleigh Length Y'	10.00	mm
Waist Diameter X'	90.77	µm
Waist Diameter Y'	91.19	µm
Waist Asymmetry	1.00	
Waist Position X'	100.09	mm
Waist Position Y'	99.58	mm
Astigmatism	0.51	mm
Relative Astigmatism	0.05	
Full Divergence Angle X'	0.528	°
Full Divergence Angle Y'	0.523	°
Divergence Asymmetry	0.99	
Original Waist		
M ² Value X'	1.03	
M ² Value Y'	1.03	
Rayleigh Length X'	2271.35	mm
Rayleigh Length Y'	2395.42	mm
Waist Diameter X'	1378.10	µm
Waist Diameter Y'	1411.51	µm
Waist Asymmetry	1.02	
Waist Position X'	3292.94	mm
Waist Position Y'	3290.87	mm
Astigmatism	2.07	mm
Relative Astigmatism	0.00	
Full Divergence Angle X'	0.035	°
Full Divergence Angle Y'	0.034	°
Divergence Asymmetry	0.97	

M² X' and M² Y' are the M² value for X' / Y' axis, calculated from the hyperbolic fit of the measured data points.

Rayleigh Length X' (Y') is the calculated distance [mm] from the beam waist position X' (Y') to the position, where the beam diameter of the appropriate axis is $\sqrt{2}$ times larger than the waist diameter. See also section [M2 Theory](#)¹³⁰.

Waist Diameter X' (Y') is the beam diameter in the X' (Y') direction at the focal point. This is the calculated minimum beam diameter [µm], derived from the curve fit. This value may differ from the smallest measured beam width.

Waist Asymmetry stands for the ellipticity at the waist position and is calculated by taking the ratio of the waist diameters in both X' and Y' directions. A waist asymmetry of 1.0 indicates a round beam spot.

$$\text{waist asymmetry} = \frac{d_{0y}}{d_{0x}}$$

Waist Position X' (Y') Z position of the beam waist (smallest beam diameter). This is the calculated beam waist position in mm derived from the curve fit. This value may differ from the position where the smallest beam width was measured.

Astigmatism is known as the effect that the beam waist in X and Y scan direction is not at the same z position. So there is a difference between the positions of minimal spot diameters z_{0y} and z_{0x} .

$$astigmatism_abs = z_{0y} - z_{0x}$$

Relative Astigmatism is calculated from the Astigmatism values divided by the mean of the Rayleigh Length in X and Y.

$$astigmatism_rel = \frac{z_{01_Y} - z_{01_X}}{(z_{R1Y} - z_{R1X}) \div 2}$$

Full Divergence Angle is explained in section [M2 Theory](#)¹³⁰.

Divergence Asymmetry is the ratio of the divergence angles in Y and X axes. Values differing from 1.0 indicate that the beam ellipticity is changing with Z position, for instance when an elliptical beam is focussed to a round spot.

$$divergence\ asymmetry = \frac{\theta_y}{\theta_x}$$

Note

All results are calculated from the applied fit!

Display the Results at a Certain Z Position

After measurement is finished, the calculated beam diameter, the beam centroid positions (X' and Y'), and the beam ellipticity can be retrieved for a certain Z position from the diagram. To do this, move the mouse pointer over the measured curves. For better visualization, the curves can be zoomed by dragging a rectangle:

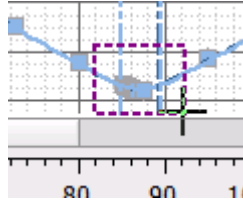

As soon as the mouse pointer hits a measurement point, its shape changes to . Click this point. The position and calculated values corresponding to the clicked point will appear in the **Calculations Results of the Selected Point** panel:

Parameter	Value	Unit
After Lens		
M ² Value X'	1.03	
M ² Value Y'	1.03	
Rayleigh Length X'	9.85	mm
Rayleigh Length Y'	10.00	mm
Waist Diameter X'	90.77	μm
Waist Diameter Y'	91.19	μm
Waist Asymmetry	1.00	
Waist Position X'	100.09	mm
Waist Position Y'	99.58	mm
Astigmatism	0.51	mm
Relative Astigmatism	0.05	
Full Divergence Angle X'	0.528	°
Full Divergence Angle Y'	0.523	°
Divergence Asymmetry	0.99	
Original Waist		
M ² Value X'	1.03	
M ² Value Y'	1.03	
Rayleigh Length X'	2271.35	mm
Rayleigh Length Y'	2395.42	mm
Waist Diameter X'	1378.10	μm
Waist Diameter Y'	1411.51	μm
Waist Asymmetry	1.02	
Waist Position X'	3292.94	mm
Waist Position Y'	3290.87	mm
Astigmatism	2.07	mm
Relative Astigmatism	0.00	
Full Divergence Angle X'	0.035	°
Full Divergence Angle Y'	0.034	°
Divergence Asymmetry	0.97	

Parameter	Value	Unit
Position	150.00	mm
Azimuth Angle	90.00	°
Ellipticity	99.48	%
Beam Diameter X'	463.30	μm
Beam Diameter Y'	465.74	μm
Centroid Position X'	4169.71	μm
Centroid Position Y'	3946.66	μm

Note

In contrast to the **Results** pane, the results shown here are calculated from the measured data point without a hyperbolic fit. Therefore, the diameter value displayed at the actual waist may differ from the X' (Y') waist diameters.

Reference Measurement

After a M^2 measurement is completed, the results can be saved and afterwards used as a reference. To do this just click the **➤** button, the active results become the reference. Further, the reference data are added to the diagram in a different color.

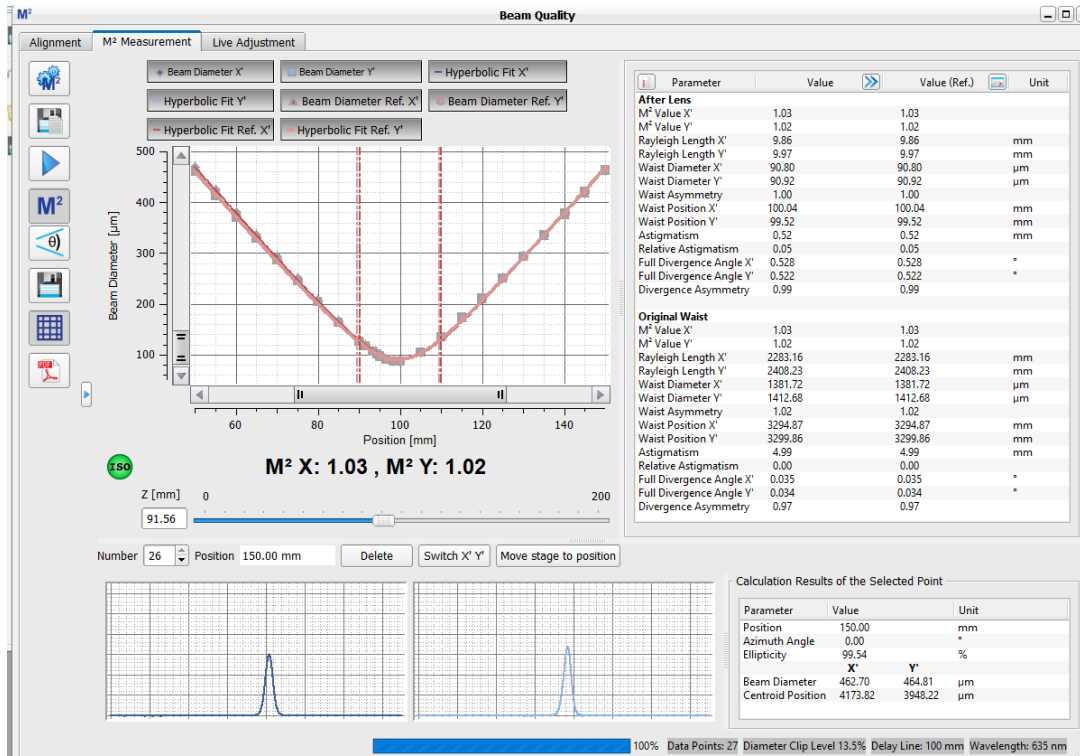

Reference Diagram Legend:

- Beam Diameter Reference X'
- Beam Diameter Reference Y'
- Hyperbolic Fit Reference X'
- Hyperbolic Fit Reference Y'

Clicking to the Clear icon deletes the reference data.

Please refer to section [Saving \$M^2\$ Test Results](#) ¹⁰¹ for details about how to save the results of the beam quality measurement.

7.2.7.7 M² Troubleshooting

Below are examples of typical problems that may occur and appropriate recommendations for resolving them.

The beam does not hit the sensor at all positions of the stage.

Perform a proper [Beam Alignment](#)⁸⁸.

A timeout occurs during a measurement.

A timeout always occurs when the Beam Profiler does not deliver a valid image within the set time-out interval. This may be caused by:

- Saturation of the photo diode. To resolve, decrease incident optical power, or alternatively use a lens with larger focal length if possible; this will increase the diameter of the focal spot and in this way lower the focal power density.
- The beam power is too low.
- The beam size is too small and no ellipse could be calculated (if Clip Level Ellipse is selected as beam width). Use a lens with a longer focal length to increase focal beam size.
- The beam is outside the aperture. Align the beam, see section [Beam Alignment](#)⁸⁸.

M² measurement is carried out, but is displayed, no M² results

Make sure for correct [Device Settings](#)³⁰.

The M² value differs substantially from the expected value.

For example, the beam has a nearly Gaussian intensity distribution and M² values are larger than 1.1:

- Check set wavelength (see [M² Settings](#)⁹⁹)
- Check Clip Level of the **Calculation Area**:
 - ▶ If the selected Clip Level is too high, the beam might be cut off and the measured beam area might be smaller than the actual beam extend. This results in a too small beam waist and a too small M² (even below 1).
 - ▶ If the selected Clip Level is too low, the Calculation Area and the measurement captures the beam plus noise around the beam. The measured beam width is then larger than the actual beam width. This leads to an increased M².

M² is smaller than 1.0

M² values < 1.0 are non-physical but may be due to

- A too small Calculation Area (Clip Level too high)
- The accuracy of the measured result. A error of 5% should be considered.
- The wavelength setting was not made properly. Set the wavelength to the correct value; M² results will be corrected without running a new measurement.

The beam profile looks distorted (particularly, at the end positions of the stage).

Even if a laser is expected to produce a Gaussian beam with M² = 1.0, the beam still can be influenced by every optical element between laser and Beam Profiler. For instance, a focusing lens could be mounted with a tilt or could produce a height distortion which results in optical aberrations and reduced beam quality.

Filters and mirrors may impact on the beam profile as well in the case that surfaces are contaminated. Clean surfaces according to manufacturer's instructions.

❑ Error message

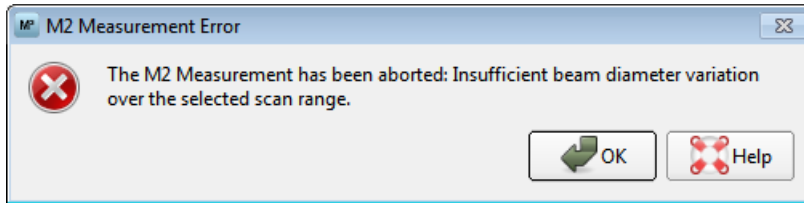

"The M2 Measurement has been aborted: Insufficient beam diameter variation over the selected scan range."

The software could not locate sufficient measurement points within the doubled Rayleigh Length.

- Extend the [Measurement Range](#).
- Select a focusing lens with a shorter focal length.
- Rule of the thumb: the beam diameter variation within the scan range should not underrun a ratio of 1:2.5 at least at one side of the beam waist - see the example below.

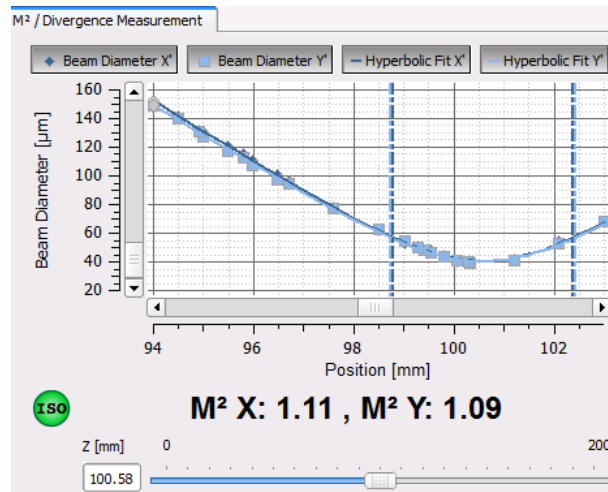

❑ Error message

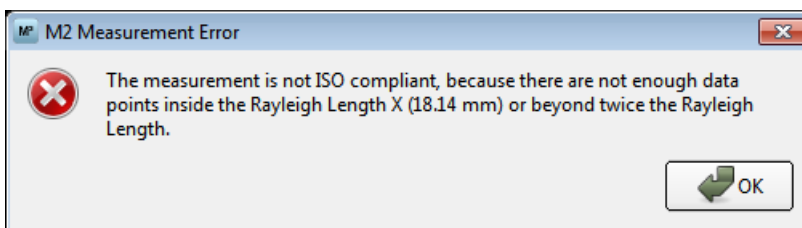

"The measurement is not ISO compliant, because there are not enough data points inside the Rayleigh Length X (Y)(xx mm) or beyond twice the Rayleigh Length"

- The software could not measure with the required resolution.
- Increase the minimum number of data points (see [M² Settings](#)).
- If the error message persists, increase the scan range as well.

❑ Error message

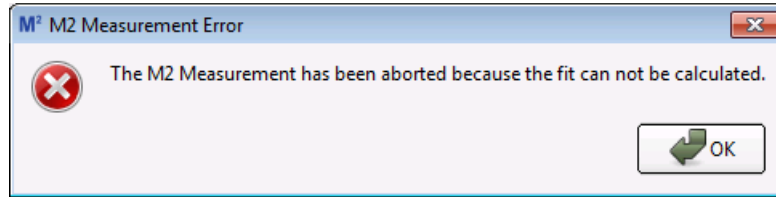

"The M2 measurement has been aborted because fit cannot be calculated."

- The calculation of the hyperbolic fit from the measured data points is impossible. Possible reasons are, for example, that the beam waist is far away from the scan range, or that no focal lens was used.
- Reset the M² Settings to default - that sets the scan range to its maximum.
- Check your setup to make sure the beam waist is within the scan range.
- If no focal lens was used, only a divergence measurement is possible!

❑ Error message

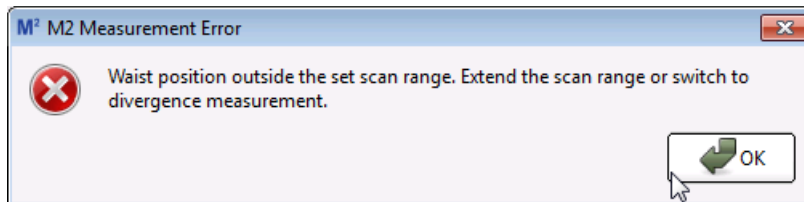

"Waist position outside the scan range. Extend the scan range or switch to divergence measurement."

- The calculation of the hyperbolic fit from the measured data points resulted in a beam waist position outside the scan range. Usually this happens if the beam waist is close to one of the scan end positions. Extend the scan range.
- Reset the M² Settings to default - that sets the scan range to its maximum

7.2.7.8 Live Adjustment

Open the Live Adjustment panel and click "start" to move the M2 stage to the lens focus plane as calculated from the inserted parameters. Now, the laser system can be adjusted and, for example, collimation can be optimized until the beam width in the focus plane is minimized.

As the stage moves to the focal plane, the Z-slider on the bottom right moves under the lens focus (LF) icon.

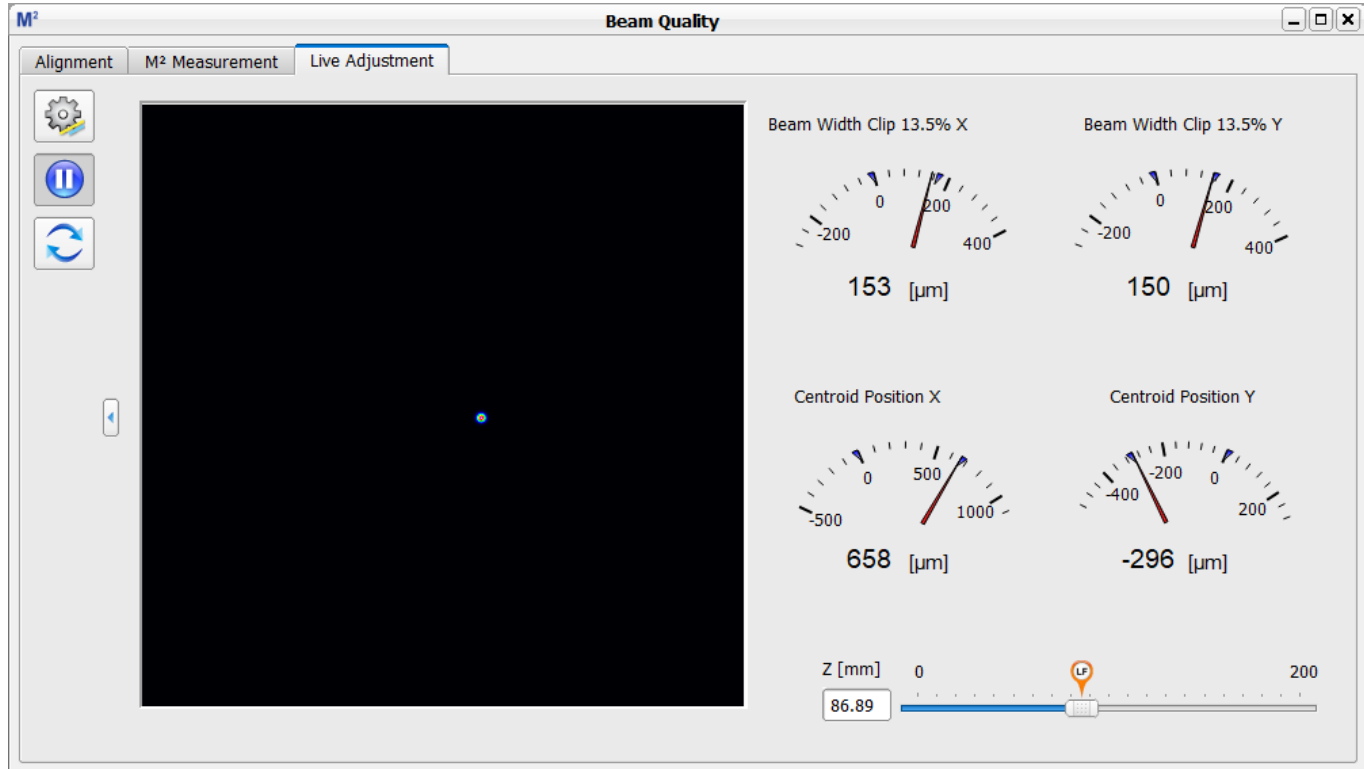

The right panel shows the Beam Width and Centroid Position in X and Y.

Beam Width: The displayed beam width is calculated based on the settings chosen in the Settings Panel of this window opened through the icon on the left.

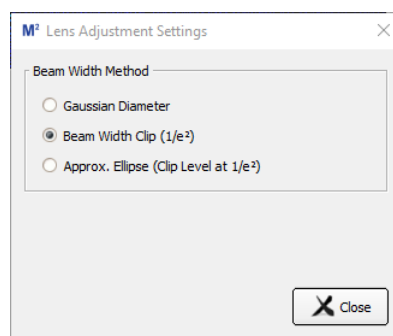

Centroid Position: The Centroid position is displayed to maintain knowledge of the beam position during adjustment.

Adjustment in Z is facilitated by the slider on the bottom right.

7.2.8 Divergence Measurement

The **Divergence Measurement** calculates the divergence angle of an unfocused convergent or divergent beam by measuring the beam diameter at different points along the beam propagation axis. A linear fit is applied to the measured data.

The measurement technique is very similar to the Beam Quality (M^2) measurement, thus the same hardware can be used with exception of the focusing lens.

The Divergence Measurement is part of the [Beam Quality](#)  measurement tool and uses the M2MS extension as well.

Please open the M2 measurement panel via the **M²** icon to arrive at the alignment and divergence measurement GUI.

To prepare for and perform a divergence measurement, please deselect the **M²** icon on the left side of the window. This will switch the interface to the divergence measurement window.



7.2.8.1 Beam Alignment

Why Beam Alignment?

The Beam Profiler has a defined input aperture, so when moving the translation stage it must be ensured that the laser beam remains within the aperture. Ideally, the beam centroid remains centered within the aperture during movement of the stage - this is a precondition for correct beam quality measurements.

The M2MS Measurement System is factory aligned. A beam that enters the M2MS exactly parallel to the stage movement direction will remain centered to the Beam Profiler aperture during stage movement. In other words, the beam alignment is dependent only on the position of the light source. In most cases the light source is a device with open beam output. In order to direct the beam under test into the M2MS, a combination of two adjustable mirrors is required, Thorlabs offers a variety of such items.

The beam alignment is executed in 2 steps, guided by a software wizard:

1. [Coarse alignment](#) : Determine the correct location of the Laser Under Test output aperture by means of an auxiliary laser (included).
2. [Fine Alignment](#)  of the Laser Under Test for minimum beam displacement and pointing angle.

7.2.8.1.1 Coarse Alignment

For a coarse alignment, Thorlabs provides an alignment laser that is included with the accessory box. For this step, the alignment laser is mounted on the M2MS in place of the Beam Profiler as described below. It is mounted and aligned in such way that its output beam enters the M2MS exactly centered in the Beam Profiler's aperture and is parallel to the stage movement direction. The alignment beam is reverse directed - it virtually exits the Beam Profiler and is re-directed by the two mirrors of the stage into the center of the laser source aperture (see the drawing in section [M2MS Operating Principle](#)^[79]).

Warning Be careful when using the Alignment Laser!



- Remove the Beam Profiler together with its mounting adapter from the M2MS base.
- Install the adjustment laser in place of the Beam Profiler and connect its 3.5 mm plug to the [Alignment Laser output \(2\)](#)^[86].
- Make sure the M2MS is switched on and connected to the control PC, the Beam Software is started and the stage has been initialized.
- Remove the focal lens from the magnetic holder.
- Switch on the alignment laser.
- Align your optical system so that the spot of the alignment laser hits the center of your light source.

7.2.8.1.2 Fine Alignment







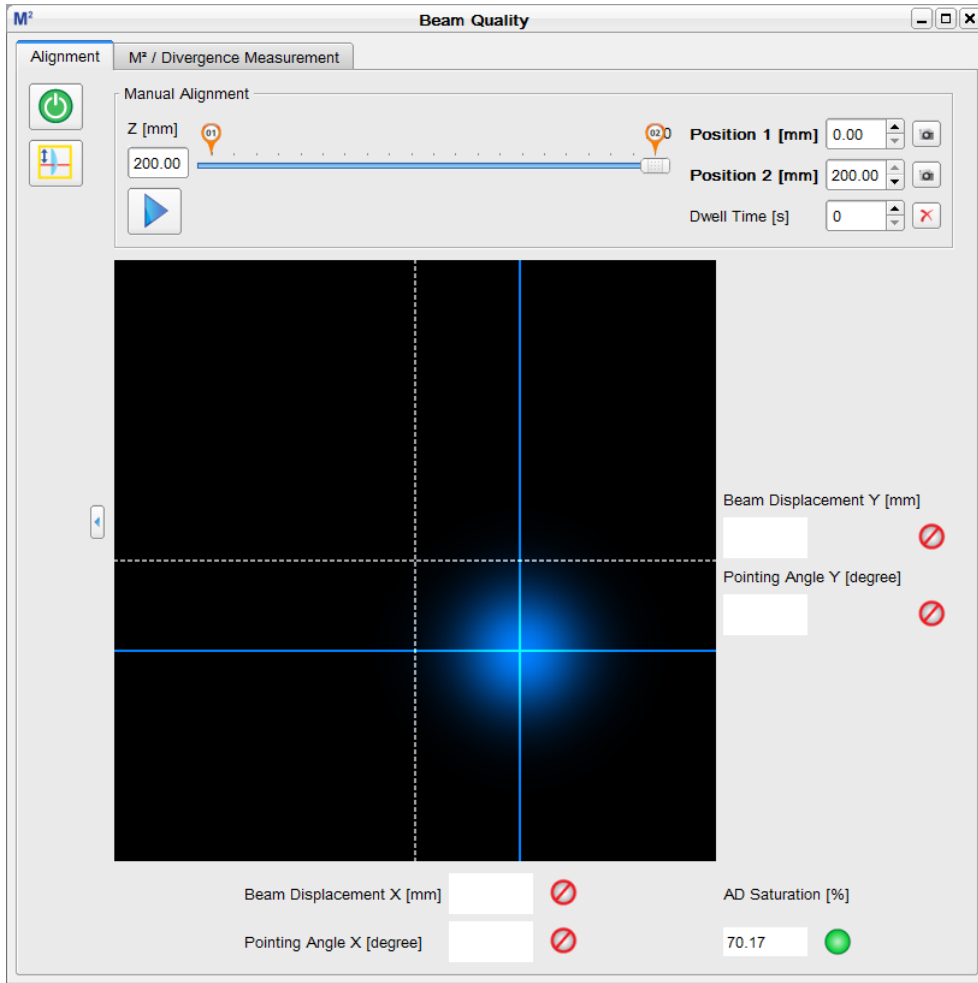





After coarse alignment, the beam under test needs to be fine-adjusted using the **Alignment** feature of the M² measurement panel. This is executed in two steps.

Preparation

- Switch off the alignment laser and replace it with your Beam Profiler.
- Make sure the BP209 beam profiler is connected to one of the M2MS USB 2.0 output ports (③, [Connection to the PC](#)^[86] section).
- Remove the focusing lens (see ③ in the drawing in the [M2MS Operating Principle](#)^[79] section).
- Make sure the BP209 Series beam profiler is recognized by the Beam Software (Toolbar  [Device Selection](#)^[87]). If it is not recognized automatically, press the **Refresh Device List**^[14] button.
- Make sure the stage is recognized and initialized. If not, press the [Refresh Stage List button](#)^[87] and after the stage was recognized, double click to the DDS100 button. The stage initializes and moves to the 200 mm position.
- Enable the Laser Under Test.
- Open M² child window either from the menu "Windows" -> "M² Quality Measurement" or by clicking the **M²** button, and switch to the Alignment tab.



Explanation of indicators and icons

	Start the Alignment Wizard 
	Start the Focusing Lens Alignment Wizard 
Z [mm]	This box shows the actual stage position; after initialization = 200 mm.
Position 1 (2) [mm]	The left and right positions for the stage movement can be entered numerically.
	Markers for left and right positions. Instead of numerical entry of the marker positions, the markers can be moved by drag-and-drop.
	When clicking these capture buttons, the stage moves to the related position, if not there yet, and captures the beam centroid position (amber crosshair). This snapshot will remain until the stage returns to the appropriate position.
	This button starts the stage loop movement mode and the stage moves continuously between positions 1 and 2. A dwell time at the end positions can be entered. During the loop mode, the software automatically captures the beam centroids (yellow cross hair) at the left and right stop.
Dwell Time	Enter the desired time [sec]. Disable the dwelling by clicking to the 
	Centroid crosshair of the actual beam position.
	Crosshair of the sensor center
Beam Displacement	Centroid shift in X (Y) direction between position 2 and 1 [mm]. The box is initially filled after the 2nd capture.
Pointing Angle	The angle [°] in X (Y) direction between the beam axis and the stage movement direction. The box is initially filled after the 2nd capture.
Alignment Success Indicator	 Alignment not successful  Alignment sufficient for correct Beam Quality Measurement (displacement < 0.65 mm, angle < 0.35°)  Good alignment (displacement < 0.35 mm, angle < 0.15°)
AD Saturation	Displays the current saturation of the Beam Profiler's AD converter. For proper beam alignment function the value must be 40 to 95 %. The green bulb to the right of the numeric field indicates the "GOOD" range.

7.2.8.1.3 Divergence Beam Alignment Wizard

Note

Make sure the rotation mount is oriented upright so that the Y axis of the BP209 Series is located vertically.

Press the **Start Wizard** button . You will be requested to select whether you want to adjust for M² or Divergence Measurement. Make your choice:

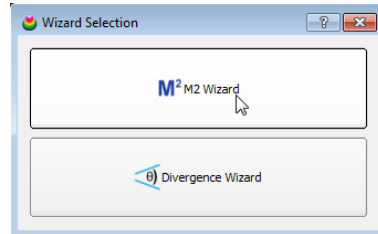

The wizard starts:

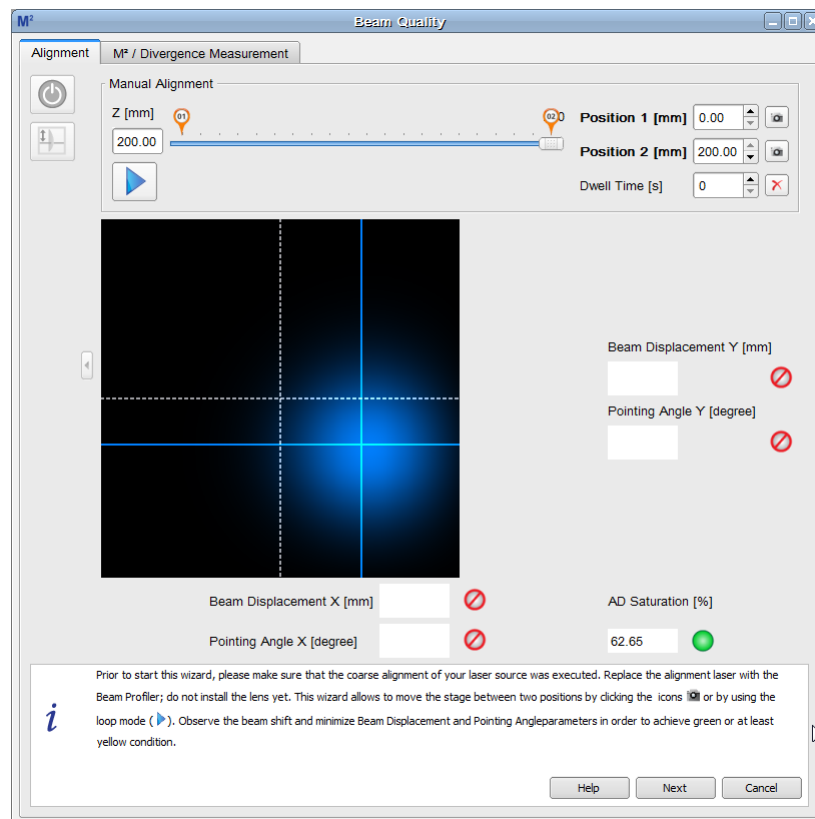

- For a successful alignment, the optical power level must be adjusted in such way that the AD Saturation is between 40 to 95 %. The green bulb to the right of the numeric field indicates the "GOOD" range. During alignment this condition must not change!
- After initialization, the stage is at Position 2 (200 mm). Click the capture button  of Position 2 - the centroid is captured, and its crosshair color changes to amber. As the actual beam centroid that is marked by a blue crosshair, is located at the same position, the resulting color is white:

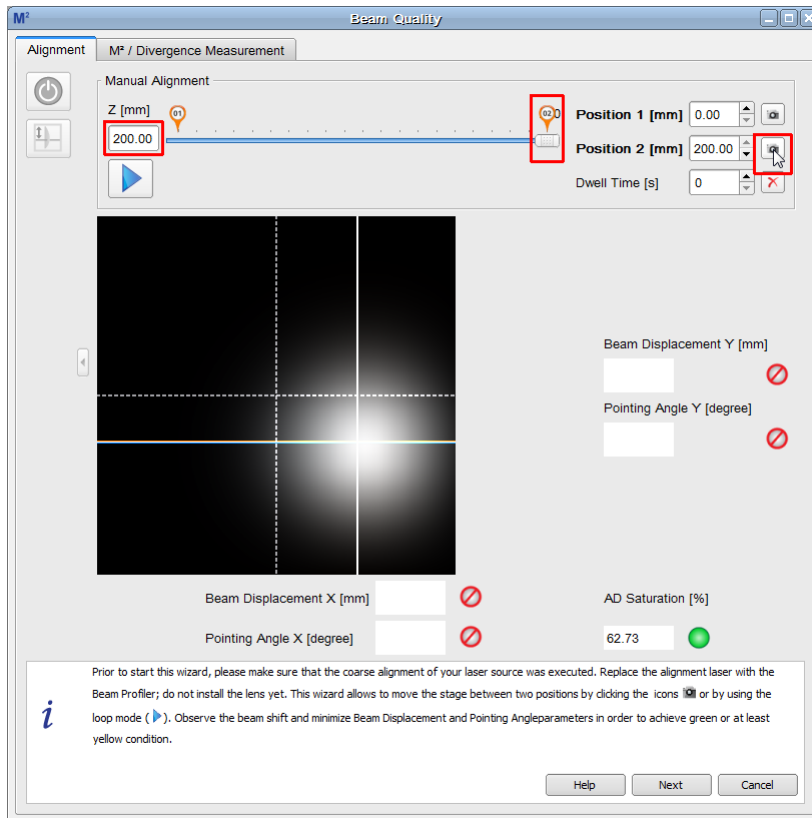

Centroid captured at Position 2

- Click to the Position 1 capture button (0 mm). The stage moves to Position 1 and captures the second centroid position:

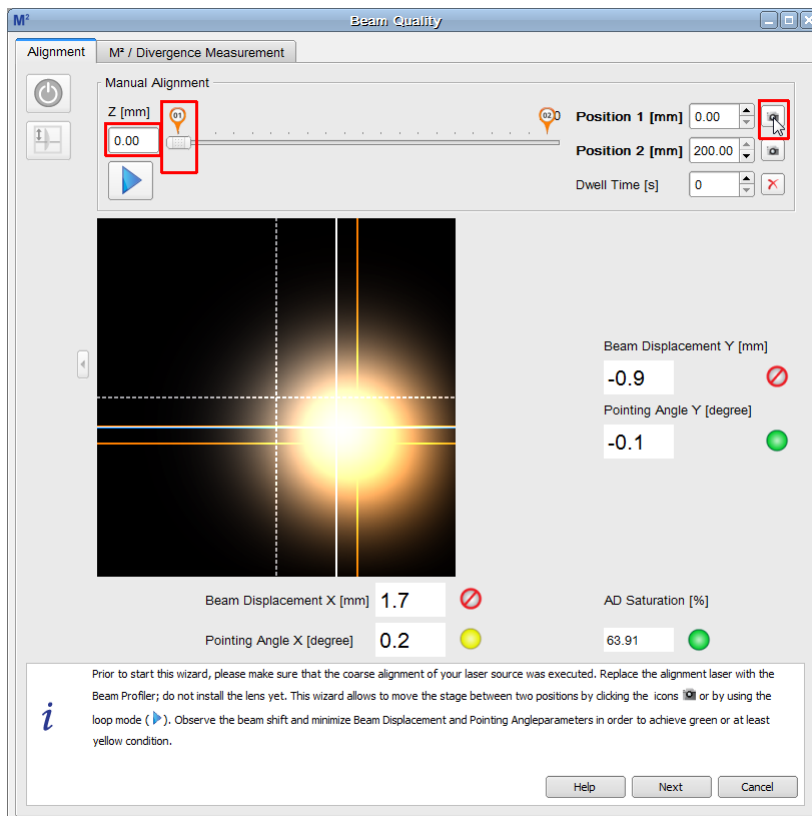

Centroid captured at Position 1

- Now, the beam displacement and the pointing angle are displayed numerically.

- Align the beam position using the controls of your laser source. Subsequently click the capture button of Position 1 and 2, observe the alignment, and improve it until all four alignment criteria are fulfilled (bulbs must be at least yellow):

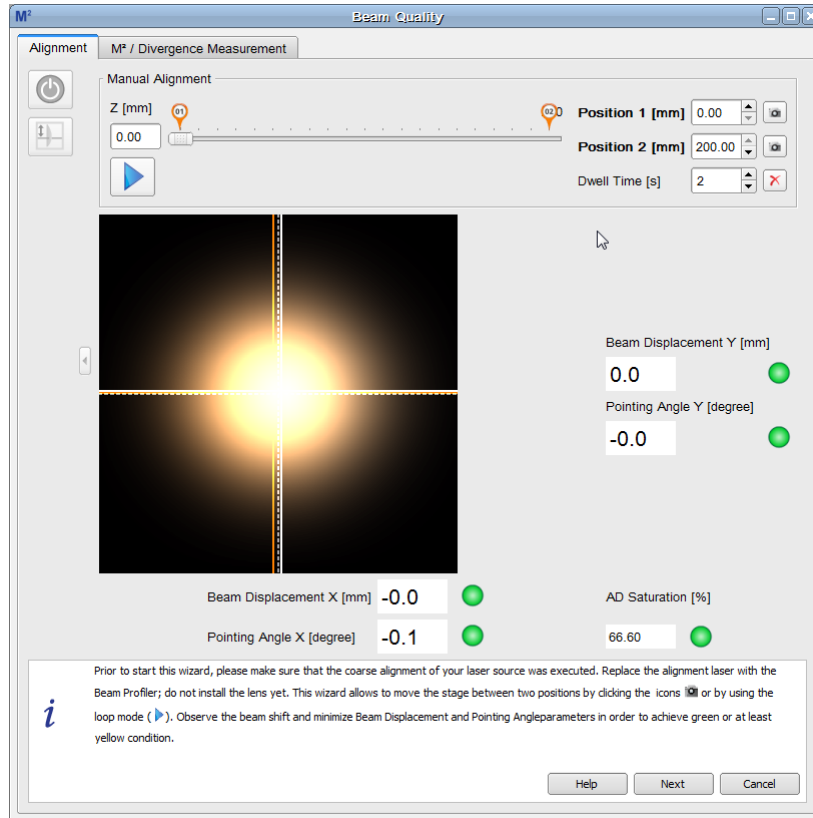

Well aligned beam position

- To toggle between the two positions, the movement of the stage between the two stop positions can be controlled automatically by the software. Just push the loop button  and enter a convenient dwell time value. The stage starts a loop move, dwelling at the stop position for the given time. During the dwelling a realignment can be made. Please keep in mind, that the numeric alignment indicators are being updated only after the next move.

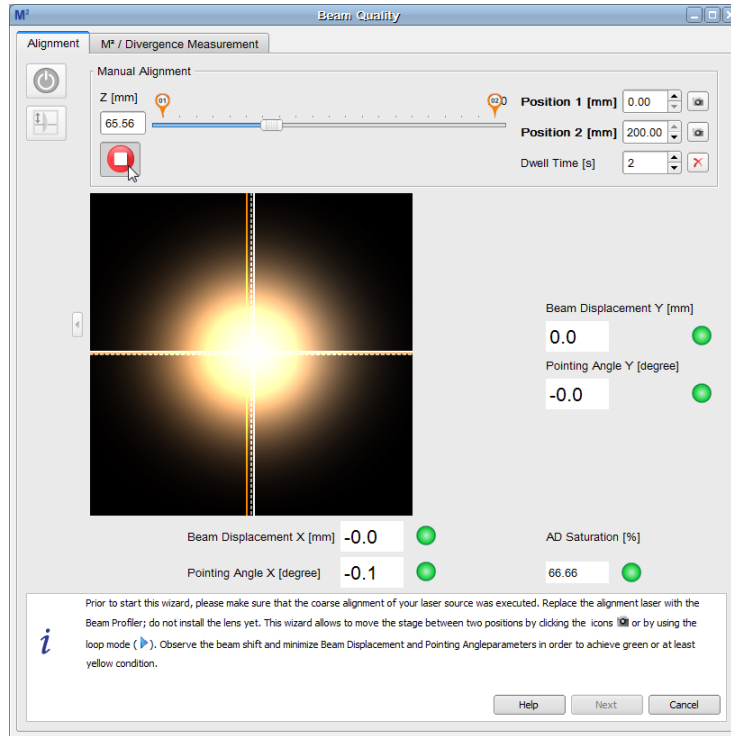

Alignment Move Loop

- To terminate the loop, click the  button.
- After finishing, click **Next** to continue.





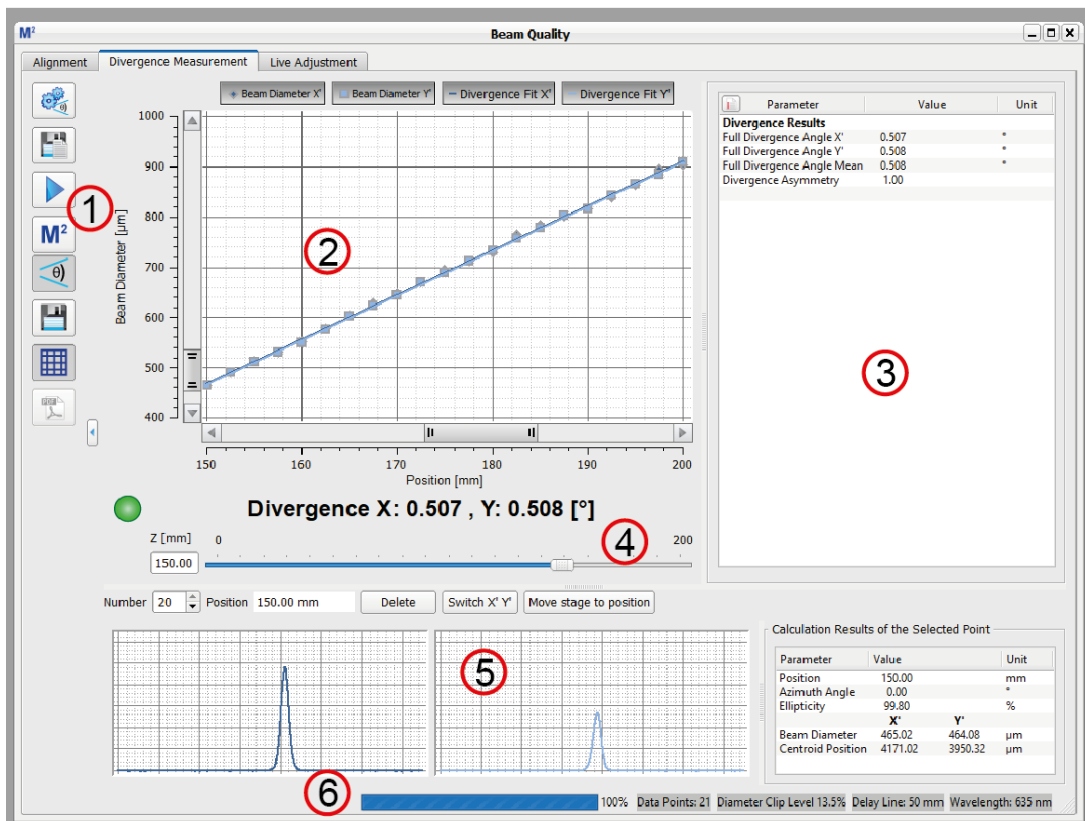



7.2.8.2 Divergence Measurement Panel

The **Divergence Measurement Panel** is derived from the M^2 Measurement window:



The Divergence Measurement panel is divided into 6 sub panels:

1. Toolbar

- | | | |
|---|---------------------|--|
|  | Divergence Settings | Opens the settings for the Divergence measurement ¹²⁵ |
|  | Auto Save Data | Save Beam Profile Data during M^2 Measurement ¹⁰³ |
|  | Start / Stop | Starts / stops a Divergence measurement |
|  | M^2 | Switches to M^2 measurement |
|  | Divergence | Switches to Divergence measurement |
|  | Save Data | After a successful Divergence measurement this button is enabled and plot data can be saved. |
|  | Grid | Disables/Enables the grid in the diagram |
|  | PDF Test Protocol | Saves the results of a Divergence measurement into a PDF file |

2. Divergence Diagram

The measured data are plotted in the diagram. The 4 buttons above the diagram configure the display: The buttons **Beam Diameter X' (Y')** enable / disable the display of the measured data at the individual positions. The buttons **Divergence Fit X' (Y')** enable / disable the curve fit to the measured data points.

After the measurement is finished, below the diagram the Divergence results for the X and Y axes are displayed. The indicator to the left shows if the measurement was successful.

The red marked button  between the toolbar and the diagram expands the diagram over the entire Divergence window.

3. Numeric Results



In this area, the beam quality measurement results are displayed in detail. Please see section [Divergence Measurement Results](#)  for more details.

4. Position Bar

The Position Bar below the Divergence Diagram shows the actual position of the translation stage as seen before in the [Alignment](#)  tab.

5. Individual Data Points

Select the **Number** of the desired measured data point in the header of this sub-panel. For this selected point, the position of stage and the profile in X and the Y of the beam is displayed. The table **Calculation Results of the Selected Point** to the right contains the following information:

Parameter	What does it show?
Position	Shows the actual Z position of the translation stage in mm.
Azimuth Angle [deg]	The displayed value is not relevant, it is always equal to 90°.
Ellipticity	The ellipticity of the fitted to an ellipse beam (see Application Note )
Beam Diameter X' [μm]	Depending on the settings  , the beam diameter is displayed based on Gauss fit, approximated ellipse or Beam Width Clip (1/e ²). The coordinate system is always related to the slit coordinates as marked on the front panel of the Beam Profiler.
Beam Diameter Y' [μm]	
Centroid Position X'	The positions of the beam centroids related to the slit coordinates as marked on the front panel of the Beam Profiler.
Centroid Position Y'	

6. Status Bar

- Measurement progress bar
- Total number of measured data points
- Beam width setting for divergence measurement
- Delay Line: Measurement range (difference between Start and Stop positions)
- Wavelength setting (not relevant for divergence calculation)

7.2.8.3 Divergence Measurement Settings

For a successful and reliable measurement, the appropriate measurement settings are essential. Click to  to enter the **Divergence Measurement Settings**.

Beam Width

The Beam Width calculation is based on an ellipse-based approximation with two possible clip levels. At the beginning of a measurement a reference angle is determined by averaging over 10 frames. This angle is then used to evaluate all following frames and ellipses.

Measurement Parameters

The wavelength is not relevant for divergence measurement.

Measurement Range

determines the distance from the starting to the stopping point over which the sleigh is driven during the measurement. **Start** has to be at least 5 mm smaller than **Stop** and ≥ 0 mm. Valid values for Stop are

$5 \text{ mm} < \text{Stop} < \text{stage length}$.

Note

It is advisable to set up a scan range > 40 mm to ensure higher accuracy. A scan over the entire translation length

is often the best choice.

Timeout is the waiting time until valid data can be retrieved from the Beam Profiler (e.g. in case of slow travel speed)

Stage Position After Scan

is not relevant for divergence measurement.

Angle Unit

Degree or milliradian can be selected.

Reset



Restores the default settings for divergence settings:

Parameter	Default Setting
Beam Width	Beam Width Clip ($1/e^2$)
Start	0 mm
Stop	200 mm
Min. Data Points	10
Timeout	15 sec

Device Settings

It is important to set Gain and Bandwidth of the Beam Profiler (see [Slit Beam Profiler Parameter](#)^[31]) to Auto.

7.2.8.4 Saving the Divergence Measurement Results

Besides the standard function "Save Divergence Measurement Results" the Thorlabs Beam Software offers an automatic saving of beam profile data when a Divergence measurement is executed.

For details, please see section [Saving the M² Measurement Results](#)  ¹⁰¹.

Note

The Divergence measurement results cannot be saved as PDF Test Protocol, only as CSV, TXT or XLS files.

7.2.8.5 Running the Divergence Measurement

The divergence measurement is designed to measure low divergent or convergent beam propagation. Therefore, the measurement requires removing any focusing elements which produce a beam waist within the scan range.

Prior to starting the measurement, make sure that:

- The beam is aligned properly - it should ideally remain centered with respect to the sensor center over the entire scan range. See chapter [Beam Alignment](#)  ¹¹⁵ for aligning the beam.
- Reflections and interferences are avoided as far as possible.
- The laser system is warmed up - depending on the source this might take up to 1 hour.
- The laser output is spatially and temporally stable.

Start the measurement by clicking the **Start** button .

While running the measurement, most of the buttons and options are disabled, e.g. the Divergence measurement settings and the toolbar. This prevents the modification of settings during a measurement.

If necessary, the measurement can be interrupted by clicking the **Stop** button .

After starting the measurement the X axis of the graph is adapted to the user-defined scan range, for example from 0 to 120 mm. The Y axis scales automatically to the recorded beam widths.

7.2.8.6 Divergence Measurement Results

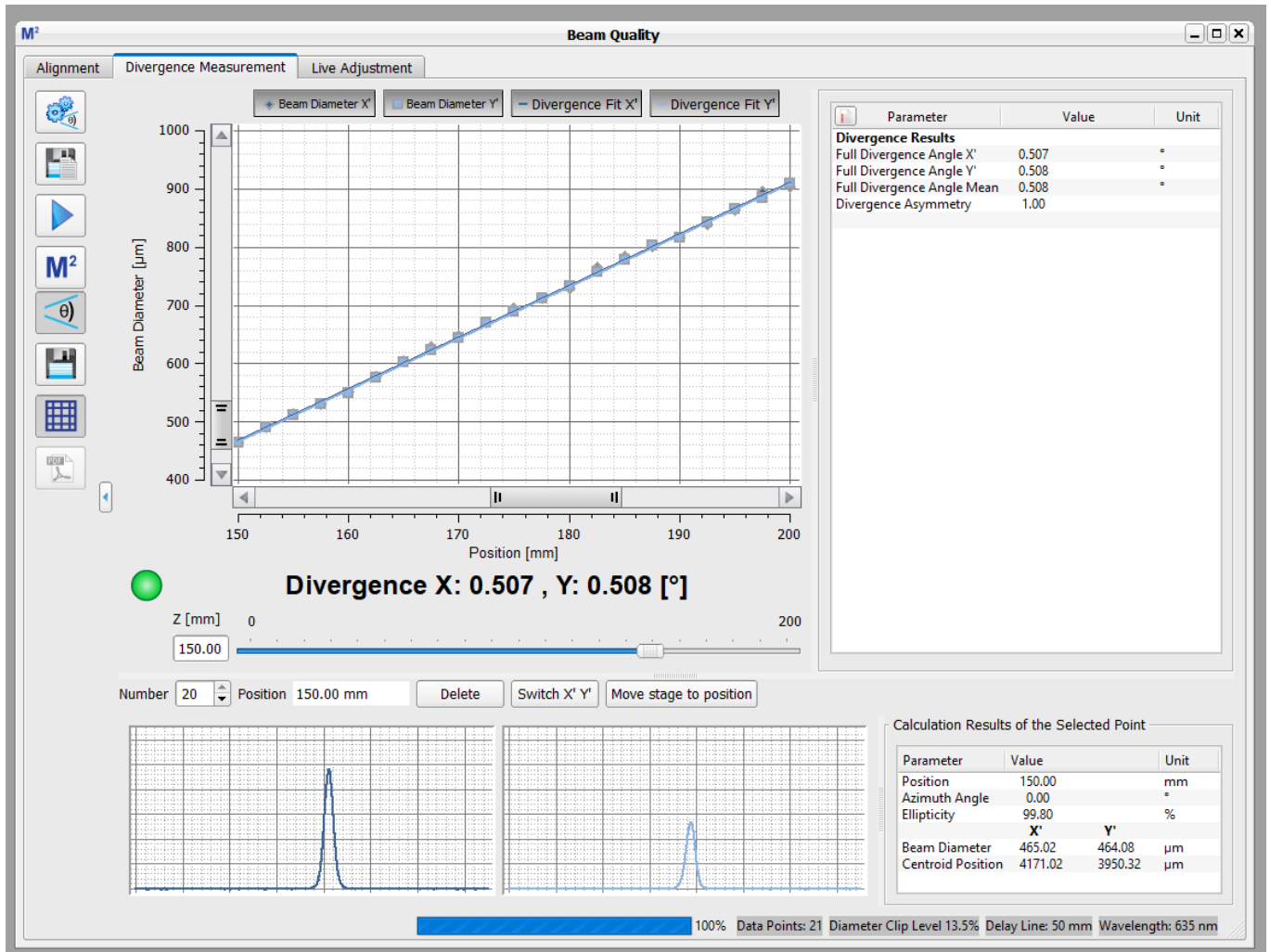

The green bulb indicates that the measurement was successful.

 **Divergence X: 0.507 , Y: 0.508 [°]**

These values can also be found in the listing of the complete **Results**.

Parameter	Value	Unit
Divergence Results		
Full Divergence Angle X'	0.507	°
Full Divergence Angle Y'	0.508	°
Full Divergence Angle Mean	0.508	°
Divergence Asymmetry	1.00	

Negative values indicate a converging beam, while positive values indicate a diverging beam.

Note

All results are calculated from the applied linear fit!

Full Divergence Angle X' (Y') is explained in chapter [M² Theory](#) ¹³⁰.

Divergence Asymmetry Asymmetry is the quotient of divergence angles in Y and X scan directions. Values differing from 1.0 indicate that the beam ellipticity is changing with z position, for instance an elliptical beam is focused to a round spot.

$$\text{divergence asymmetry} = \frac{\theta_y}{\theta_x}$$

Reference Measurement

The actual measurement results can be saved and used as reference afterwards, same as for [M² Measurement Results](#) .

7.2.8.7 Live Adjustment

As for the M^2 Measurement, the Divergence Measurement Panel also offers the option for a Live Adjustment of the laser system.

Open the Live Adjustment panel and click "start" to move the M2 stage to the lens focus plane as calculated from the inserted parameters. Now, the laser system can be adjusted and, for example, collimation can be optimized until the beam width in the focus plane is minimized.

As the stage moves to the focal plane, the Z-slider on the bottom right moves under the lens focus (LF) icon.

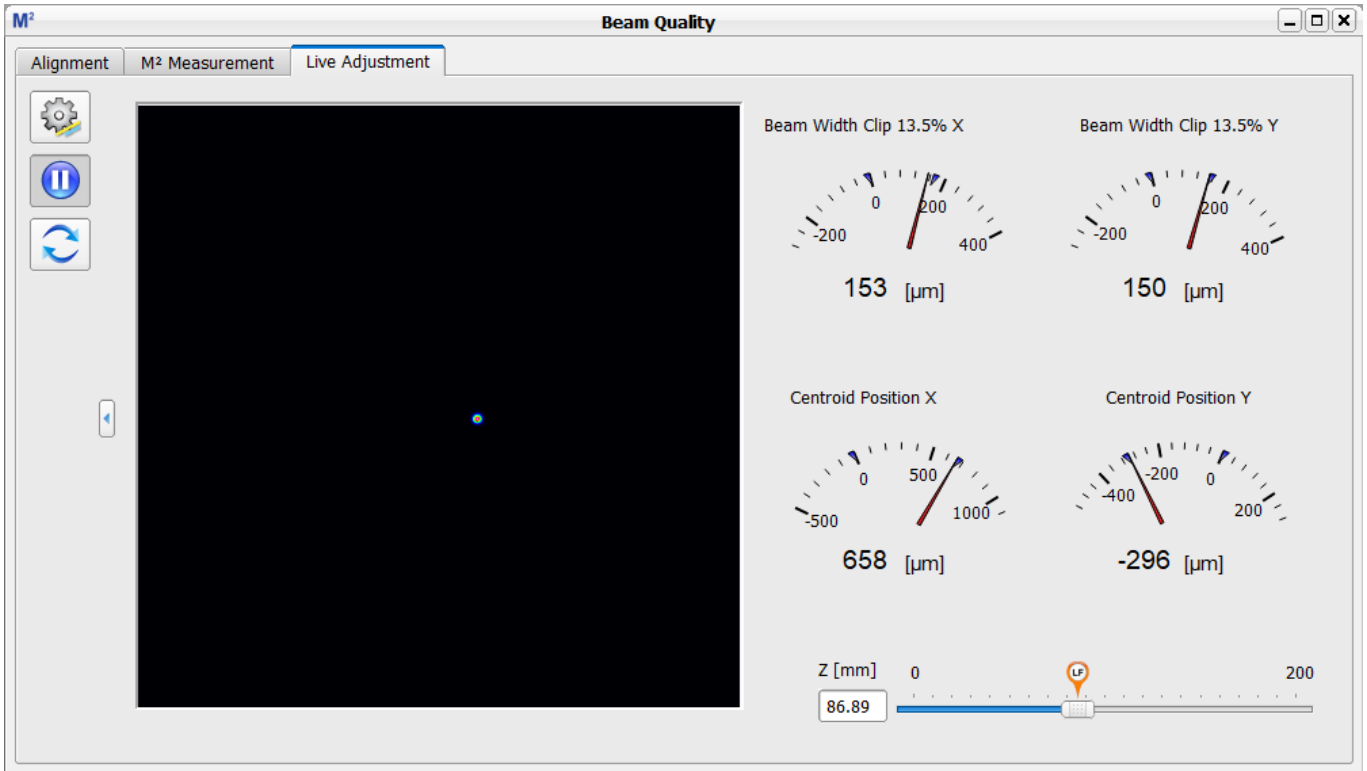

The right panel shows the Beam Width and Centroid Position in X and Y.

Beam Width: The displayed beam width is calculated based on the settings chosen in the Settings Panel of this window opened through the icon on the left.

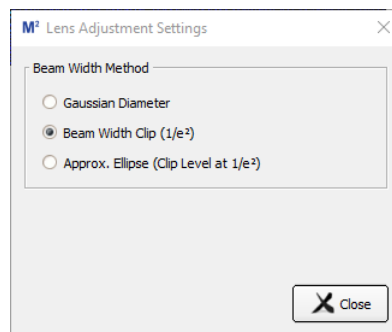

Centroid Position: The Centroid position is displayed to maintain knowledge of the beam position during adjustment.

Adjustment in Z is facilitated by the slider on the bottom right.

7.2.9 M² Theory

The diameter $d(z)$ of a focused laser beam increases with distance z from its waist position and can be calculated as follows:

$$d(z) = d_0 \sqrt{1 + \left(\frac{z}{z_R}\right)^2}$$

with

d_0	Waist Diameter
z_R	Rayleigh Length
λ	Wavelength

In this equation it was assumed that the waist location is at zero. Otherwise z has to be replaced with $(z-z_0)$

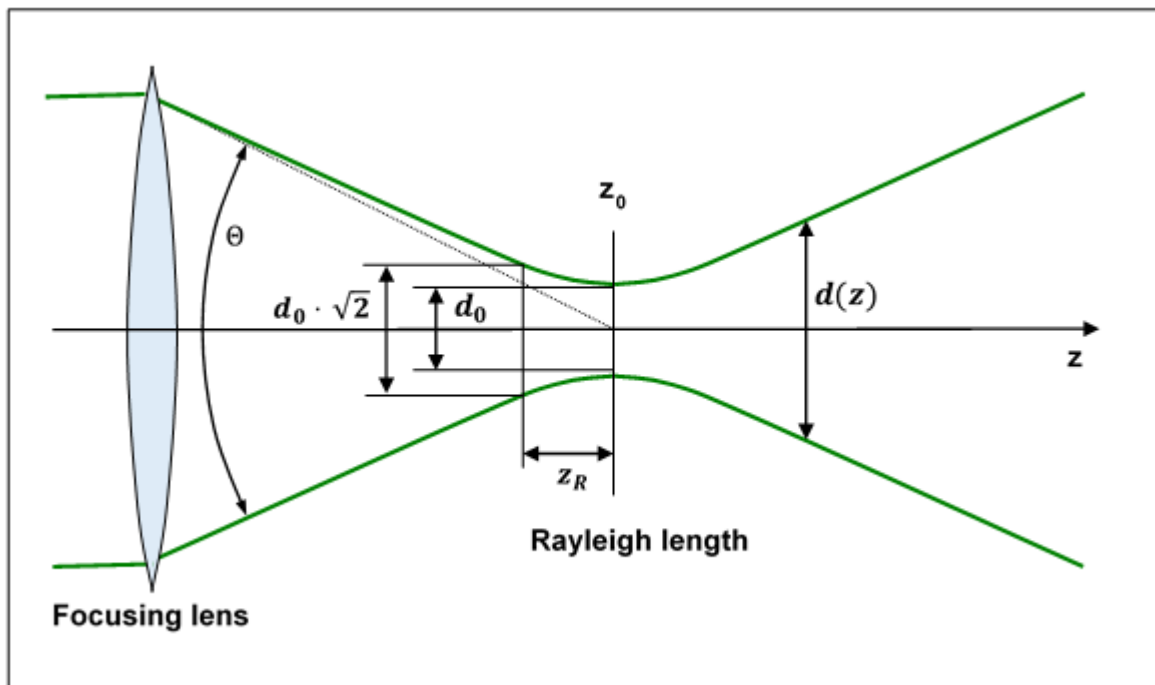

The Rayleigh Length z_R determines the distance from the beam waist to the position where the beam diameter has increased by a factor of $\sqrt{2} = 1.41$ compared to the minimum diameter at the waist.

From the equation for $d(z)$ it can be seen that the beam diameter increases linearly with z in the far field ($z \gg z_R$). The full divergence angle can be calculated by

$$\theta \approx \frac{d(z; z \gg z_R)}{z} = \frac{d_0}{z_R}$$

For laser beams with fundamental mode TEM_{00} (Gaussian Beam shape) it can be theoretically shown that the Rayleigh Length is given by

$$z_{RG} = \frac{\pi d_{0G}^2}{4\lambda}$$

Thus the product of the minimum diameter of a Gaussian beam (at waist) and the divergence angle $d_{0G} \cdot \theta_G$ (AKA 'Beam Parameter Product', BPP) is constant for a given wavelength:

$$d_{0G} \theta_G = \frac{4\lambda}{\pi}$$

For mode mixture (MM) beams, i.e. beams which feature higher order modes than just the fundamental mode TEM₀₀, the product of beam diameter and divergence increases by a factor of M².

$$d_{0MM} \theta_{MM} = M^2 d_{0G} \theta_G = M^2 \frac{4\lambda}{\pi}$$

Finally, the times-diffraction-limit factor M² is calculated by

$$M^2 = \frac{\pi}{4\lambda} d_{0MM} \theta_{MM}$$

The Rayleigh Length is now given by

$$z_{RMM} = \frac{\pi d_{0MM}^2}{M^2 \lambda}$$

The reciprocal of the times-diffraction-limit factor M² is called the beam propagation factor or beam quality K.

$$K = \frac{1}{M^2}$$

The following table illustrates the differences between a perfect Gaussian beam and non-perfect beam.

Parameter	Gaussian Beam	Mode Mixture Beam
Times-diffraction-limit factor M ²	1	> 1
Beam propagation factor = Beam quality K	1	< 1
Beam waist for given lens	minimal	larger
Divergence angle θ at given beam waist d_0	narrow	wider

Reasons for Non-Ideal Gaussian Beam with M² > 1

Using a Gaussian beam is preferred because of its minimum divergence angle and the ability to achieve the minimal focus diameter. Differences to Gaussian shape can be due to

- existence of higher order modes
- amplitude and phase distortions due to inhomogeneous gain medium in lasers
- presence of extraordinary beams

These distortions lead to a larger beam waist compared to Gaussian beams when the same focal lens is used. This results in a lower maximum achievable power density in the focal point.

Comparison of Propagation Between Fundamental Mode TEM₀₀ (Ideal Gaussian beam) and Mode Mixture Beams

With a given divergence angle (i.e. knowing the focal length of the lens), the fundamental mode alone produces the theoretically smallest possible beam waist (green curve). If beam quality worsens (red curve), the beam waist increases. If divergence is fixed, beam waist increases linearly by the factor M² compared to the underlying Gaussian.

$$d_{0MM} (\theta_{MM} = \theta_G) = M^2 \cdot d_{0G}$$

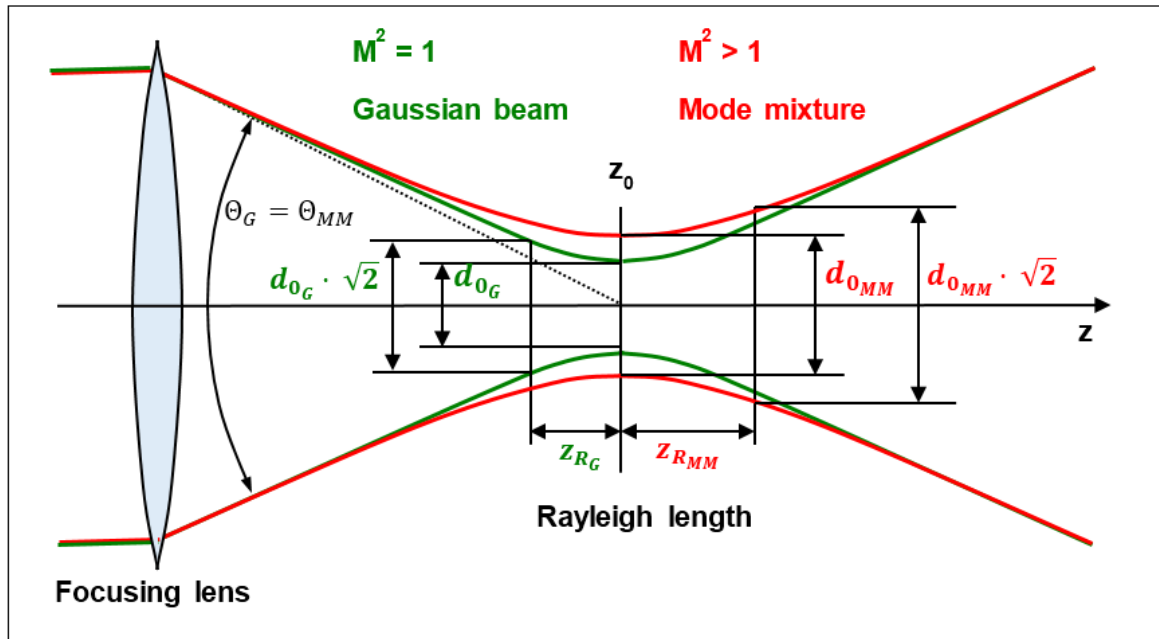

The appropriate power density at z_0 is reduced by a factor $(M^2)^2$. Also the Rayleigh Length increases by a factor of M^2 .

$$z_{RMM}(\theta_{MM} = \theta_G) = \frac{\pi d_{0MM}^2}{M^2 \cdot 4\lambda} = M^2 \frac{\pi d_{0G}^2}{4\lambda} = M^2 \cdot z_{RG}$$

8 Write Your Own Application

In order to write your own application, you need a specific instrument driver and some tools for use in different programming environments. The driver and tools are installed to your computer during software installation and cannot be found in the installation package.

In this section the location of drivers and files, required for programming in different environments, are given for installation under Windows® 8.1 and Windows®^F 10 (32 and 64 bit).

In order to fully support 64 bit LabView version, the installation package provides two installer components, the 32bit and the 64bit component:

- for Windows® 8.1 (32/64 bit) and Windows® 10 (32/64 bit): Install "Thorlabs Beam VXiIpn Instrument Driver (32bit)"
- for Windows® 8.1 (64 bit) and Windows® 10 (64 bit): Install "Thorlabs Beam VXiIpn Instrument Driver (64 bit)"

In other words, the 32 bit VXiIpn driver works with both 32 and 64 bit operating systems, while the 64 bit driver requires a 64 bit operating system.

Note

Beam Software and drivers contain 32 bit and 64 bit applications.

In 32 bit systems, only the 32 bit applications are installed to

`C:\Program Files\...`

In 64 bit systems the 64 bit components are being installed to

`C:\Program Files\...`

while necessary 32 bit components can be found at

`C:\Program Files (x86)\...`

In the table below you will find a summary of what files you need for particular programming environments.

Programming environment	Necessary files
C, C++, CVI	*.h (header file) *.lib (static library)
C#	.net wrapper dll
Visual Studio	*.h (header file) *.lib (static library) or .net wrapper dll
LabView	*.fp (function panel) and NI VISA instrument driver. Beside that, LabVIEW driver vi's are provided with the *.lib container file. Note: LabVIEW drivers and components are installed only, if a LabVIEW installation was recognized.

Note

All above environments require also the NI VISA instrument driver dll !

During NI-VISA Runtime installation, a system environment variable `VXIPNPPATH` for including files is created. It stores information where the drivers are installed, usually to `C:\Program Files\IVI Foundation\VISA\WinNT\`.

This is the reason why a system reboot is required after the installation of a NI-VISA Runtime: This environment variable is necessary for installation of the application software components.

In the next sections the location of above files for all hardware, supported by Beam Software drivers, is described in detail.

8.1 32 bit Operating System

Note

According to the VPP6 (Rev6.1) Standard the installation of the 32 bit VXIpnnp driver includes both the WINNT and GWINNT frameworks.

VXIpnnp Instrument driver:

C:\Program Files\IVI Foundation\VISA\WinNT\Bin\TLBP2_32.dll

Note

This instrument driver is required for all development environments!

Header file

C:\Program Files\IVI Foundation\VISA\WinNT\include\TLBP2.h

Static Library

C:\Program Files\IVI Foundation\VISA\WinNT\lib\msc\TLBP2_32.lib

Function Panel

C:\Program Files\IVI Foundation\VISA\WinNT\TLBP2\TLBP2.fp

Online Help for VXIpnnp Instrument driver:

C:\Program Files\IVI Foundation\VISA\WinNT\TLBP2\Manual\TLBP2.html

NI LabVIEW driver

The LabVIEW Driver is a 32 bit driver and compatible with 32 bit NI-LabVIEW versions 8.5 and higher only.

C:\Program Files\National Instruments\LabVIEW xxxx\Instr.lib\TLBP2...
...\TLBP2.llb

(LabVIEW container file with driver vi's and an example. "LabVIEW xxxx" stands for actual LabVIEW installation folder.)

python driver

C:\Program Files\IVI Foundation\VISA\WinNT\TLBP2\Examples\Python

.net wrapper dll

C:\Program Files\Microsoft.NET\Primary Interop Assemblies...
...\Thorlabs.TLBP2_32.Interop.dll

C:\Program Files\IVI Foundation\VISA\VisaCom\...
...\Primary Interop Assemblies\Thorlabs.TLBP2_32.Interop.dll

Example for C

Project file:

C:\Program Files\IVI Foundation\VISA\WinNT\TLBP2\Examples\...
...\CVI Sample\CSample.prj

Source file:

C:\Program Files\IVI Foundation\VISA\WinNT\TLBP2\Examples\...
...\CVI Sample\CSample.c

Executable sample demo:

C:\Program Files\IVI Foundation\VISA\WinNT\TLBP2\Examples\...
...\CVI Sample\CSample.exe

Example for C#**Solution file:**

```
C:\Program Files\IVI Foundation\VISA\WinNT\TLBP2\Examples...  
...\MS VS 2012 CSharp Demo\DotNet_Sample\Thorlabs.BP2_CSharpDemo...  
...\Thorlabs.BP2_CSharpDemo.sln
```

Project file:

```
C:\Program Files\IVI Foundation\VISA\WinNT\TLBP2\Examples ...  
...\MS VS 2012 CSharp Demo\DotNet_Sample\Thorlabs.BP2_CSharpDemo...  
...\Thorlabs.BP2_CSharpDemo.csproj
```

Executable sample demo:

```
C:\Program Files\IVI Foundation\VISA\WinNT\TLBP2\Examples ...  
...\MS VS 2012 CSharp Demo\DotNet_Sample\Thorlabs.BP2_CSharpDemo...  
...\output\Thorlabs.BP2_CSharpDemo.exe
```

Example for LabVIEW

```
C:\Program Files\National Instruments\LabVIEW xxxx\Instr.lib\TLBP2...  
...\TLBP2.llb
```

(LabVIEW container file with driver vi's and an example. "LabVIEW xxxx" stands for actual LabVIEW installation folder.)

Example for Python

```
C:\Program Files\IVIFoundation\VISA\WinNT\TLBP2...  
...\Examples\Python\TLBP2_Sample.py
```

8.2 64 bit Operating System

Note

According to the VPP6 (Rev6.1) Standard the installation of the 64 bit VXIpnnp driver includes the WINNT, WIN64, GWINNT and GWIN64 frameworks. That means, that the 64 bit driver includes the 32 bit driver as well.

In case of a 64 bit operating system, 64bit drivers and applications are installed to

```
"C:\Program Files"
```

while the 32 bit files - to

```
"C:\Program Files (x86)"
```

Below are listed both installation locations, so far applicable.

VXIpnnp Instrument driver:

```
C:\Program Files (x86)\IVI Foundation\VISA\WinNT\Bin\TLBP2_32.dll
C:\Program Files\IVI Foundation\VISA\Win64\Bin\TLBP2_32.dll
C:\Program Files\IVI Foundation\VISA\Win64\Bin\TLBP2_64.dll
```

Note

This instrument driver is required for all development environments!

Header file

```
C:\Program Files (x86)\IVI Foundation\VISA\WinNT\include\TLBP2.h
C:\Program Files\IVI Foundation\VISA\Win64\include\TLBP2.h
```

Static Library

```
C:\Program Files (x86)\IVI Foundation\VISA\WinNT\lib\msc...
...\TLBP2_32.lib
C:\Program Files\IVI Foundation\VISA\Win64\lib\msc\TLBP2_32.lib
C:\Program Files\IVI Foundation\VISA\Win64\Lib_x64\msc\TLBP2_64.lib
```

Function Panel

```
C:\Program Files (x86)\IVI Foundation\VISA\WinNT\TLBP2\TLBP2.fp
```

Online Help for VXIpnnp Instrument driver:

```
C:\Program Files (x86)\IVI Foundation\VISA\WinNT\TLBP2\...
...\Manual\TLBP2.html
```

NI LabVIEW driver

The LabVIEW Driver supports 32bit and 64bit NI-LabVIEW2009 and higher.

```
C:\Program Files\National Instruments\LabVIEW xxxx\Instr.lib\TLBP2...
...\TLBP2.llb
```

(LabVIEW container file with driver vi's and an example. "LabVIEW xxxx" stands for actual LabVIEW installation folder.)

python driver

```
C:\Program Files (x86)\IVI Foundation\VISA\WinNT\TLBP2\Examples\Python
```

.net wrapper dll

C:\Program Files (x86)\Microsoft.NET\Primary Interop Assemblies...
 ...\Thorlabs.TLBP2_32.Interop.dll

C:\Program Files (x86)\IVI Foundation\VISA\VisaCom\...
 ...\Primary Interop Assemblies\Thorlabs.TLBP2_32.Interop.dll

C:\Program Files\IVI Foundation\VISA\VisaCom64\...
 ...\Primary Interop Assemblies\Thorlabs.TLBP2_64.Interop.dll

Example for C**Project file:**

C:\Program Files (x86)\IVI Foundation\VISA\WinNT\TLBP2\Examples\...
 ...\CVI Sample\CSample.prj

Source file:

C:\Program Files (x86)\IVI Foundation\VISA\WinNT\TLBP2\Examples\...
 ...\CVI Sample\CSample.c

Executable sample demo:

C:\Program Files (x86)\IVI Foundation\VISA\WinNT\TLBP2\Examples\...
 ...\CVI Sample\CSample.exe

Example for C#**Solution file:**

C:\Program Files (x86)\IVI Foundation\VISA\WinNT\TLBP2\Examples...
 ...\MS VS 2012 CSharp Demo\DotNet_Sample\Thorlabs.BP2_CSharpDemo...
 ...\Thorlabs.BP2_CSharpDemo.sln

Project file:

C:\Program Files (x86)\IVI Foundation\VISA\WinNT\TLBP2\Examples ...
 ...\MS VS 2012 CSharp Demo\DotNet_Sample\Thorlabs.BP2_CSharpDemo...
 ...\Thorlabs.BP2_CSharpDemo.csproj

Executable sample demo:

C:\Program Files (x86)\IVI Foundation\VISA\WinNT\TLBP2\Examples ...
 ...\MS VS 2012 CSharp Demo\DotNet_Sample\Thorlabs.BP2_CSharpDemo...
 ...\output\Thorlabs.BP2_CSharpDemo.exe

Example for LabView

C:\Program Files (x86)\National Instruments\LabVIEW xxxx\In-
 str.lib\TLBP2...
 ...\TLBP2.llb

(LabVIEW container file with driver vi's and an example. "LabVIEW xxxx" stands for actual LabVIEW installation folder.)

Example for Python

C:\Program Files (x86)\IVIFoundation\VISA\WinNT\TLBP2...
 ...\Examples\Python\TLBP2_Sample.py

9 Maintenance and Repair

Protect the Beam Profiler from adverse environmental conditions. The Beam Profiler is not water resistant.

Attention

To avoid damage to the instrument, do not expose it to spray, liquids or solvents!

The unit does not need a regular maintenance by the user.

The BP209 Series does not contain any modules that could be repaired by the user himself. If a malfunction occurs, please contact [Thorlabs](#) first. If necessary, you will be provided with the required return information.

Do not remove covers!

9.1 Version and Other Information

The menu entry **Help → About Thorlabs** displays relevant Beam Software data.

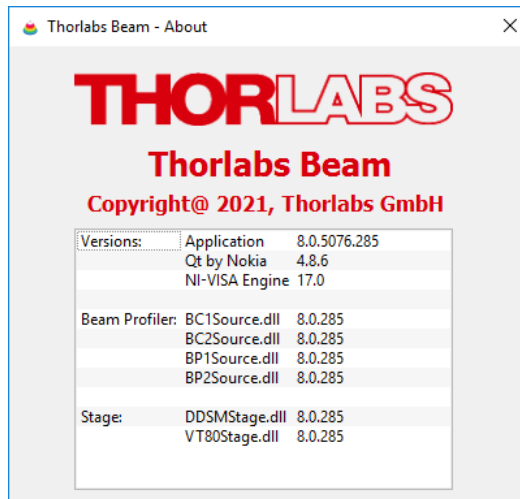

In case of a support request, please submit the software version of the application. This will help to locate the error.

9.2 Cleaning

The Beam Profiler has parts (slits) mounted to the drum that are sensitive to mechanical impacts. Do not attempt to clean the slits using tissue, cotton buds or compressed air - the slit might be damaged. In case a visible contaminant is found, please contact us. A list of our worldwide branches can be found at the [end of this manual](#).

The outer surfaces of the instrument may be cleaned using a wet lint-free cloth.

9.3 Troubleshooting

❑ Software Installation failed

In order to install the Beam Software on your PC, you need administrator privileges. Otherwise, an installation is impossible. If you have trouble with software installation, please contact your system administrator.

❑ No Beam Profiler recognized





If after starting of Beam Software no instrument was recognized, the Device Settings button in the Menu bar is crossed out ()

- Check if you have connected a BP209 Series instrument.
- Check the USB cable. Make sure you are using the supplied with instrument cable.
- Check proper driver installation
- Check if the green LED lights up - LED off indicates that the Beam Profiler's firmware was not loaded.

See section [Connection to the PC](#)  for details.

You may unplug and reconnect the Beam Profiler to a different USB port or use a different USB cable. Wait a few seconds, until the green LED lights up. Then click "**Refresh Device List**" within the Device Selection panel. See chapter Start the Application for a detailed description.

❑ Results and graphs are not being updated

- The device is in the pause mode. Resume the device by clicking the Start  button in the Menu bar.
- **Max Hold**  was activated - switch off **Max Hold** mode by clicking the  icon.
- The "**Average over frame**" rate might be high, check its value in the [Beam Settings panel](#) .

9.3.1 Warnings and Errors

Warnings and error messages will appear in the status bar as soon as improper measurement conditions are detected. For this reason, please keep always an eye on the status bar in order to prevent measurement errors. Below some examples are shown:

 Scan Speed not stabilized! Samples: 3760 | Scan Rate: 20.00 Hz | Target Resolution: 1.20 µm | 0.60 fps

❑ Scan speed not stabilized!

Explanation The detected drum rotation speed differs from the set value. Proper measurements are impossible.

Resolving This warning may appear shortly after the Scan Rate has been changed - the drum's inertia causes a delay in reaching a new set value. After reaching the set value, this warning disappears. If it remains, the Beam Profiler seems to be damaged and need factory repair - please contact [Thorlabs](https://www.thorlabs.com)¹⁶² for return instruction.

❑ Device in Pause Mode

Explanation In the Menu bar, the Pause  or Next Frame  button was pressed

Resolving Press in Menu bar the Start  button.

Attention

As soon as an error or warning is displayed in the status bar, the calculated beam parameters are not reliable!

10 Application Note

This chapter contains some background information about the measurement methods of beam profiles.

Beam profiles can be characterized by a number of different parameters. We aim to offer a software that allows to measure all usual beam parameters based on ISO11146-1 standard.

In the following sections detailed explanations are given to the measured parameters.

10.1 Coordinate Systems

Lab System

The lab system (AKA reference system) of coordinates is based on the true X and Y coordinate orientation of the drum in accordance with the marking on the front panel.

Transformed System

The transformed system of coordinates is based on the calculated beam axes (minor and major axes for elliptical fit or for 4σ beam diameter).

10.2 Raw Data Measurements

Lab (or Reference or Sensor) Coordinate System

4σ Beam Width is the width of a beam in X and Y axes (centroids), derived from the second moment calculation:

$$d_{ax} = 4 * \sigma_x \quad d_{ay} = 4 * \sigma_y$$

where σ_x and σ_y are the standard deviation of the horizontal or vertical marginal distribution, respectively:

$$\sigma_x = \sqrt{\frac{\sum [(x - x_{centroid})^2 * p(x,y)]}{Sum_Intensity}} \quad \sigma_y = \sqrt{\frac{\sum [(y - y_{centroid})^2 * p(x,y)]}{Sum_Intensity}}$$

and

$$\sigma_{xy} = \sqrt{\frac{\sum [(x - x_{centroid}) * (y - y_{centroid}) * p(x,y)]}{Sum_Intensity}}$$

Note

The **4σ Beam Width** measurement is not in conformity with ISO11146! Displayed results are for information only!

In accordance with ISO11146-3, beam diameters shall be defined at a $1/e^2$ clip level for Slit Beam Profilers, while for Camera Beam Profilers the $4\sigma X'$ and $4\sigma Y'$ beam widths apply.

Peak Position

X, Y: position of the pixel with highest intensity (AD value) which is found first with respect to reference position.

$$R = \sqrt{X^2 + Y^2}$$

is the dial distance of peak position's pixel from the reference position (= sensor center).

Centroid Position

X, Y and R position (first moment), calculated over all pixels with respect to the above reference position.

$$X = \text{SUM} [x * p(x,y)] / I \quad Y = \text{SUM} [y * p(x,y)] / I$$

where:

$p(x,y)$ intensity at location (x,y) ;

I total intensity;

SUM of pixels taken over the entire area

AD Saturation

Saturation level of the instrument's AD converter. For a good SNR (signal-to-noise ratio) the saturation level should be not below 40% and not be above 95%.

Total Power

Total power measured through the [ND filter](#)¹⁵ in the drum (photo diode current with respect to the typical wavelength-dependent responsivity).

10.3 Ellipse (Fitted)

The beam shape is fit to an ellipse using the set clip level.

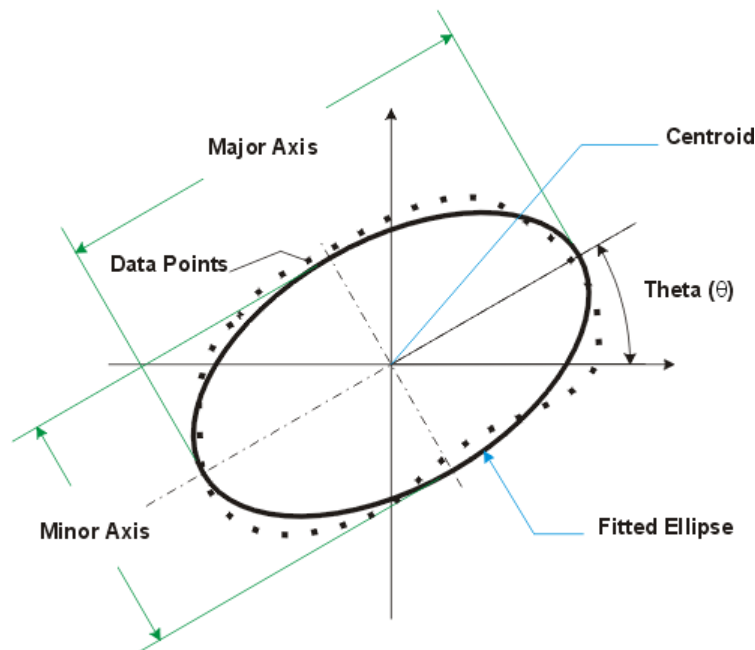

Diameter (clip level) is given for the minor axis (**min**), major axis (**max**) and their arithmetic mean value.

Ellipticity and **Eccentricity** of the beam are defined in ISO 11146-1 as

$$\text{Ellipticity} = \frac{d_{\min}}{d_{\max}} \quad \text{Eccentricity} = \frac{\sqrt{d_{\max}^2 - d_{\min}^2}}{d_{\max}}$$

with d_{\min} = minor axis and d_{\max} = major axes of the approximated beam ellipse.

Orientation denotes the angle θ between the major ellipse axis and the horizontal X axis. Range: $-90^\circ < \theta \leq 90^\circ$.

10.4 X-Y-Profile Measurement

Beam Width at Clip Level (xx%)

Beam width is the distance between the two points where the opposite edges of a captured beam profile are bisected by the X or Y axis and the intensity falls to a certain percentage of the peak power. This percentage is called clip level.

Preferred clip levels are for instance 50 % (Full Width at Half Maximum) and 13.53% (exactly $1/e^2$). Since the Beam Software supports a variable clip level, the beam width is always displayed with its clip level in brackets.

Note

Please note that "Beam Width" is always the diameter, not the radius of the beam.

10.5 Gaussian Fit Measurement

The beam profiles of coherent light sources, such as lasers and the output of fibers, show a distribution more or less close to Gaussian. If focusing a Gaussian beam, it converges into a waist, after which it diverges.

The Gaussian fit uses the method of least squares in order to fit the X and Y cross section profile of a beam to a Gaussian shape. In other words, the Gaussian fit represents an approximation of captured measurement data to a Gaussian distribution.

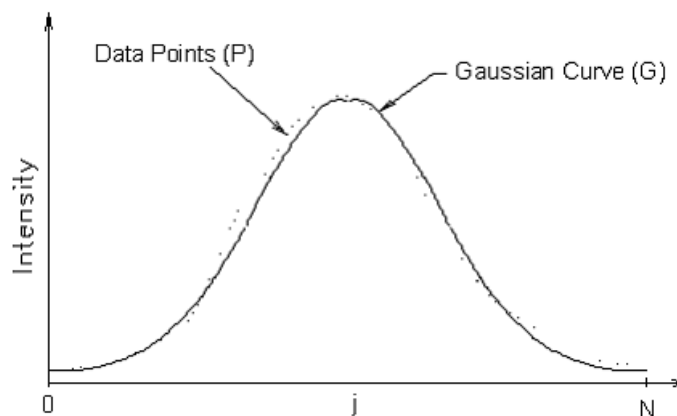

Gaussian Intensity is the intensity distribution of the Gaussian fitted beam profile.

Gaussian Diameter is the width of the Gaussian fitted profile at a $1/e^2$ intensity clip level.

10.6 Bessel Fit

One of the most important properties of a Bessel beam is that it is non-diffractive. This means, apart from Gaussian beams, their shape does not change during propagation, and they do not have a focus in terms of a location with highest intensity along the propagation direction. Its distribution can be described by a Bessel function of the first kind.

Ideal Bessel beams do not exist, but a good approximation - a Bessel-Gauss beam - can be achieved by focusing a Gaussian beam using an axicon lens, a narrow annular aperture, or an axisymmetric diffraction grating. The output of some step index fibers can also have a profile close to a Bessel beam.

The Bessel fit approximates a given beam profile to a Bessel function distribution.

11 Appendix

11.1 Technical Data BP209 Series

Item #	BP209-VIS(/M)	BP209IR1(/M)	BP209-IR2(/M)
Beam Profiler Specifications			
Wavelength Range	200 - 1100 nm	500 - 1700 nm	900 - 2700 nm
Detector Type	Si, UV enhanced	InGaAs	Extended InGaAs
Aperture Diameter	9 mm		
Scan Method	Scanning Slits, Knife Edge		
Slit Size	5 μm and 25 μm		
Minimum Beam Diameter	2.5 μm		
Maximum Beam Diameter	9 mm ¹⁾		
Sampling Resolution	0.12 to 1.24 μm (Depending on Scan Rate)		
Scan Rate	2.0 to 20.0 s ⁻¹ (Continuously Variable)		
Optical Power Range	1 μW to 10 W (Depending on Beam Diameter and Model)		
Amplifier Bandwidth	16 to 1000 kHz in 11 steps (@ -1dB)		
Sample Frequency	0.2872 to 2.0 MHz		
Dynamic Range	78 dB (Amplifier Switchable)		
Photodiode Bias Voltage	0 / -1.5 V (Switchable)	0 V	
Signal Digitization	15 bit		
Dimensions	\varnothing 79.5 mm x 60 mm (Including Rotation Mount)		
Minimum Pulse Rate	10 Hz ²⁾		
Software			
Displayed Parameters and Features	X-Y-Profile, Centroid Position, Peak Position, Pseudo 3D Profile, Beam Width Clip Level / Second Moment (4σ), Gaussian Fit Applicable, Colored Pass/Fail Test		
Compliance with Standards	ISO 11146 (Beam Widths, Divergence Angle and Beam Propagation Factor)		
General System Requirements	Windows® 8.1 or later, USB 2.0 High Speed Port		
M² Analysis System			
Compatible M ² Options	M2MS M ² Measurement Systems		
Compliance with Standards	ISO 11146		
Measured Parameters ³⁾	M ² , Waist Width, Waist Position, Rayleigh Length, Divergence, Beam Pointing, Waist Asymmetry, Astigmatism		
General			
Operating Temperature	5 °C to 35 °C		
Storage Temperature	-40 °C to 70 °C		
Warm-up time for rated accuracy	15 min		

¹⁾ BP209-VIS(/M); BP209IR1(/M): Beam diameter error <10% at \varnothing 9 mm
BP209-IR2(/M): Beam diameter error <20% at \varnothing 9 mm for beam divergence <5°

²⁾ 300 kHz using M² Option

³⁾ using M² Option

All technical data are valid at 23 \pm 5°C and 45 \pm 15% rel. humidity

11.2 Technical Data M2MS-BP209

Item #	M2MS-BP209VIS-AL	M2MS-BP209VIS-AL/M	M2MS-BP209VIS	M2MS-BP209VIS/M
Specification M2MS-Combination				
Beam Profiler	BP209-VIS	BP209-VIS/M	BP209-VIS	BP209-VIS/M
Wavelength Range	250 - 600 nm		400 - 1100 nm	
Beam Diameter Range	20 μ m - 9 mm (at Beam Profiler Input Aperture)			
Power Range	1 μ W to 10 W, Depending on Beam Diameter			
Translation Stage	DDS100/M			
Travel Range	100mm			
Velocity (Max)	500 mm/s			
Effective Translation Range	200 mm, -100 mm to +100 mm from Focal Point			
Lens Focal Length	250 mm			
Optical Axis Height	70 mm (without additional feet)			
M ² Measurement Range	1.0 - No Upper Limit			
Typical M ² Accuracy	\pm 5 %, Depending on Optics and Alignment			
Accepted Beam Diameter for 5% Uncertainty	20 μ m - 4.5 mm (at Beam Profiler Input Aperture)			
Minimum Detectable Divergence Angle	<0.1 mrad			
Applicable Light Sources	CW and Pulsed Sources \geq 300 kHz			
Typical Measurement Time	15 - 30 s, Depending on Beam Shape and Settings			
General				
Size	300 mm x 175 mm x 130mm			
Weight	4.6kg			

Item #	M2MS-BP209IR2	M2MS-BP209IR2/M
Specification M2MS-Combination		
Beam Profiler	BP209-IR2	BP209-IR2/M
Wavelength Range	900 - 2700 nm	
Beam Diameter Range	20 μ m - 9 mm (at Beam Profiler Input Aperture)	
Power Range	1 μ W to 10 W, Depending on Beam Diameter	
Translation Stage	DDS100/M	
Travel Range	100mm	
Velocity (Max)	500 mm/s	
Effective Translation Range	200 mm, -100 mm to +100 mm from Focal Point	
Lens Focal Length	250 mm	
Optical Axis Height	70 mm (without additional feet)	
M ² Measurement Range	1.0 - No Upper Limit	
Typical M ² Accuracy	\pm 5 %, Depending on Optics and Alignment	
Accepted Beam Diameter for 5% Uncertainty	20 μ m - 4.5 mm (at Beam Profiler Input Aperture)	
Minimum Detectable Divergence Angle	<0.1 mrad	
Applicable Light Sources	CW and Pulsed Sources \geq 300 kHz	
Typical Measurement Time	15 - 30 s, Depending on Beam Shape and Settings	
General		
Size	300 mm x 175 mm x 130mm	
Weight	4.6kg	

11.3 Technical Data M2MS Extension Sets

Item #	M2MS	M2MS-AL
M2MS Extension Set General Specifications		
Wavelength Range	400-2700 nm ¹⁾	250-600nm ¹⁾
Beam Profiler Compatibility	BC207 series, BP209 series	
Translation Stage	DDS100/M	
Travel Range	100mm	
Velocity (Max)	500 mm/s	
Effective Translation Range	200 mm, -100 mm to +100 mm from Focal Point	
Lens Focal Length	250 mm	
Optical Axis Height	70 mm (without additional feet)	
M ² Measurement Range	1.0 - No Upper Limit	
Typical M ² Accuracy	\pm 5 %, Depending on Optics and Alignment	
Minimum Detectable Divergence Angle	<0.1 mrad	
Applicable Light Sources	CW, Pulsed	
Size	300 mm x 175 mm x 109mm (without Beam Profiler)	
Typical Measurement Time	15 - 30 s, Depending on Beam Shape and Settings	

¹⁾ Depending on the Beam Profiler Type

11.4 Typical Photodiode Response Curves

The following diagrams show typical response curves photodiodes used in BP209 Series models.

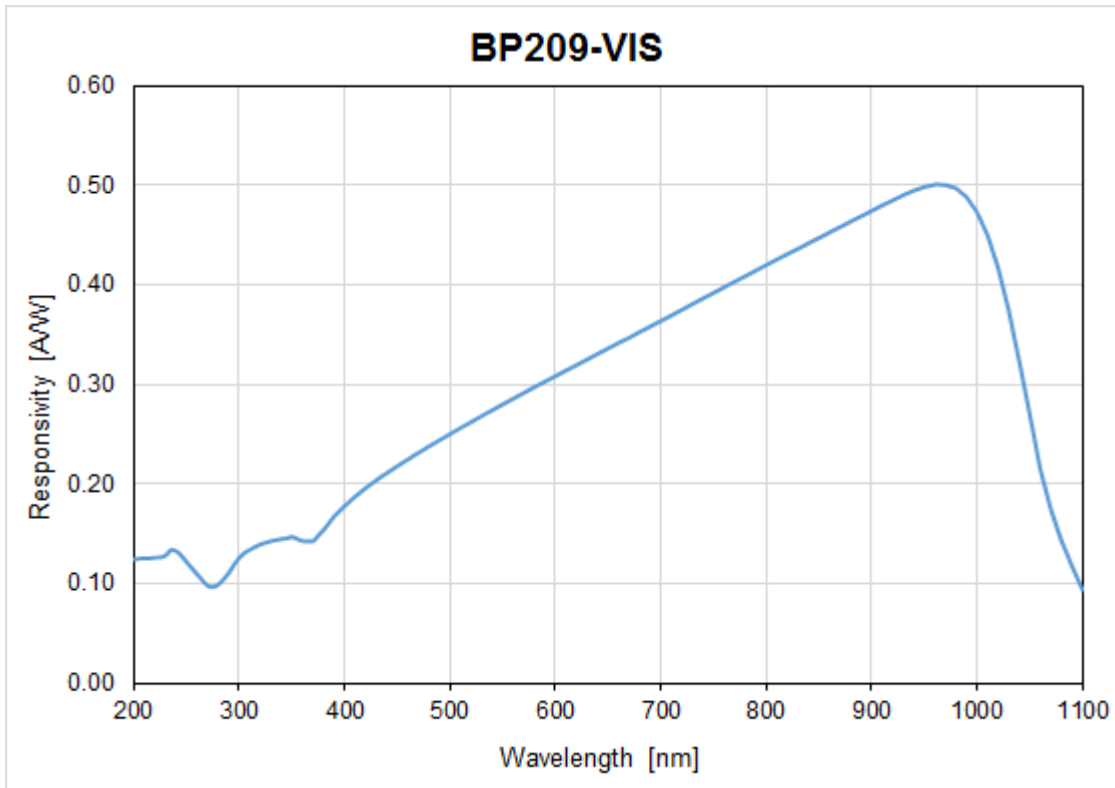

Typical Responsivity - UV-enhanced Si Photodiodes

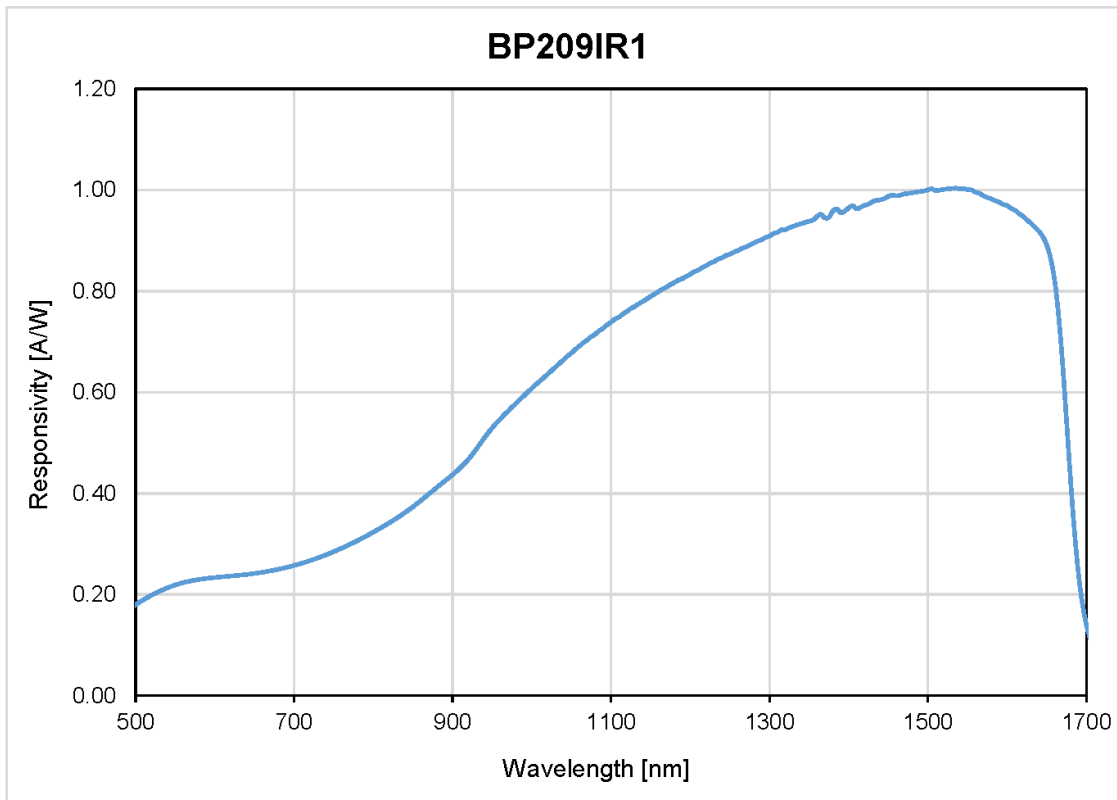

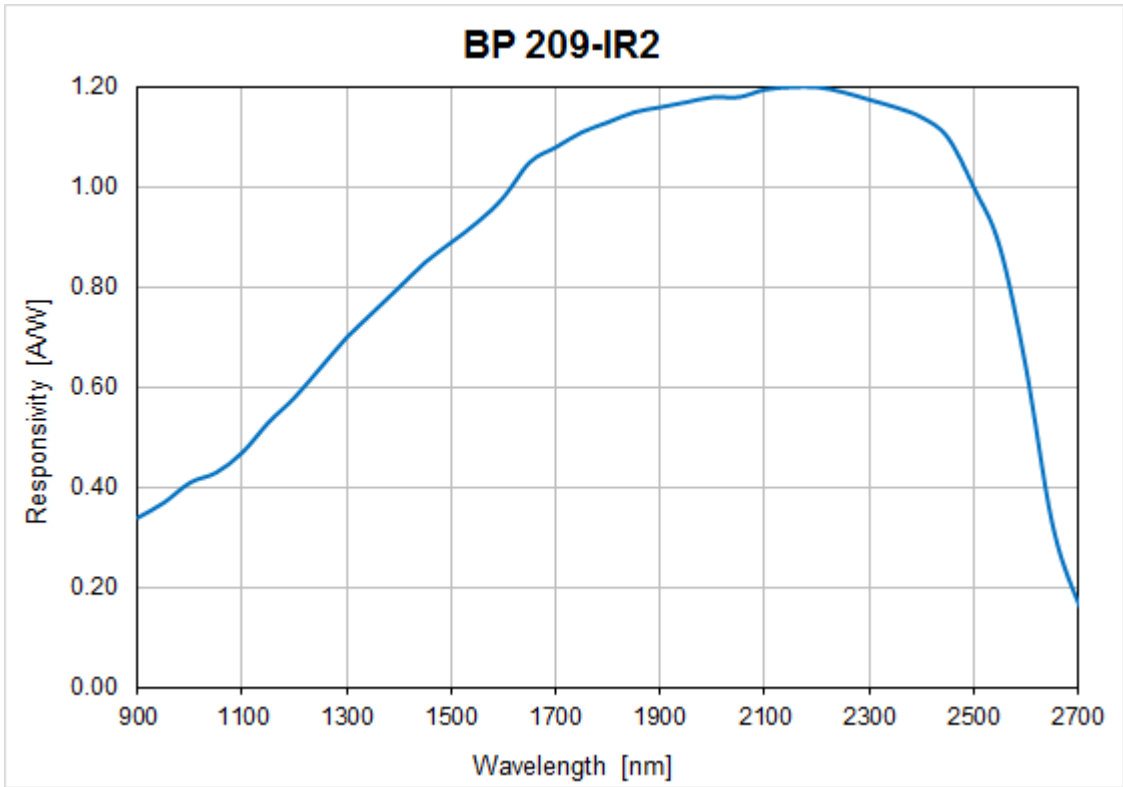

Typical Responsivity - Extended InGaAs Photodiodes

11.5 Power Ranges

The max. usable input power depends on the beam diameter and the wavelength: the smaller the beam width the lower the maximum input power because of the maximum power density of the photodiode. The diagram below shows the allowed input power range at the wavelength of maximum responsivity (BP209-VIS ~ 980 nm; BP209IR1 ~ 1550nm; BP209-IR2 ~ 2200nm):



Note

Please note that these operating power ranges apply to measurements made using the slits in scanning-slit or knife-edge mode; these limits may be reduced when measuring total power. Scanning-slit mode transmits a fraction of the beam power to the photodetector, and during knife-edge mode the un-attenuated, $<\text{Ø}20 \mu\text{m}$, full beam is transmitted to the photodetector. In addition to the two pairs of slits, the rotating drum contains an aperture fitted with a neutral density (ND) filter that, once per rotation, allows the full attenuated beam to reach the photodetector. The power in the attenuated full beam may fall outside of the operating range of the detector. In this case, an error message will be displayed in the status box. However, beam shape measurements using the slits can still be made, assuming the power transmitted by the slits falls within the limits plotted in the diagram.

11.6 Initial Settings

When the BP209 Series is used first time with the BEAM software, the following initial settings are applied:

Parameter	Default value
Scan Rate	10.0 1/s
Scan Rate Correction	enabled
Wavelength	635 nm (BP209-VIS) 900 nm (BP209IR1, BP209-IR2)
Photodiode Bias	off
Aperture Width	full width (9 mm)
Active Slit Pair	5 μ m
Scanning Method	Slit Scanning
Gain And Bandwidth Control	
Auto Gain Index	ON
Bandwidth Slit X	125 kHz
Bandwidth Slit Y	125 kHz
Auto Baseline Correction	0

11.7 Drawing BP209

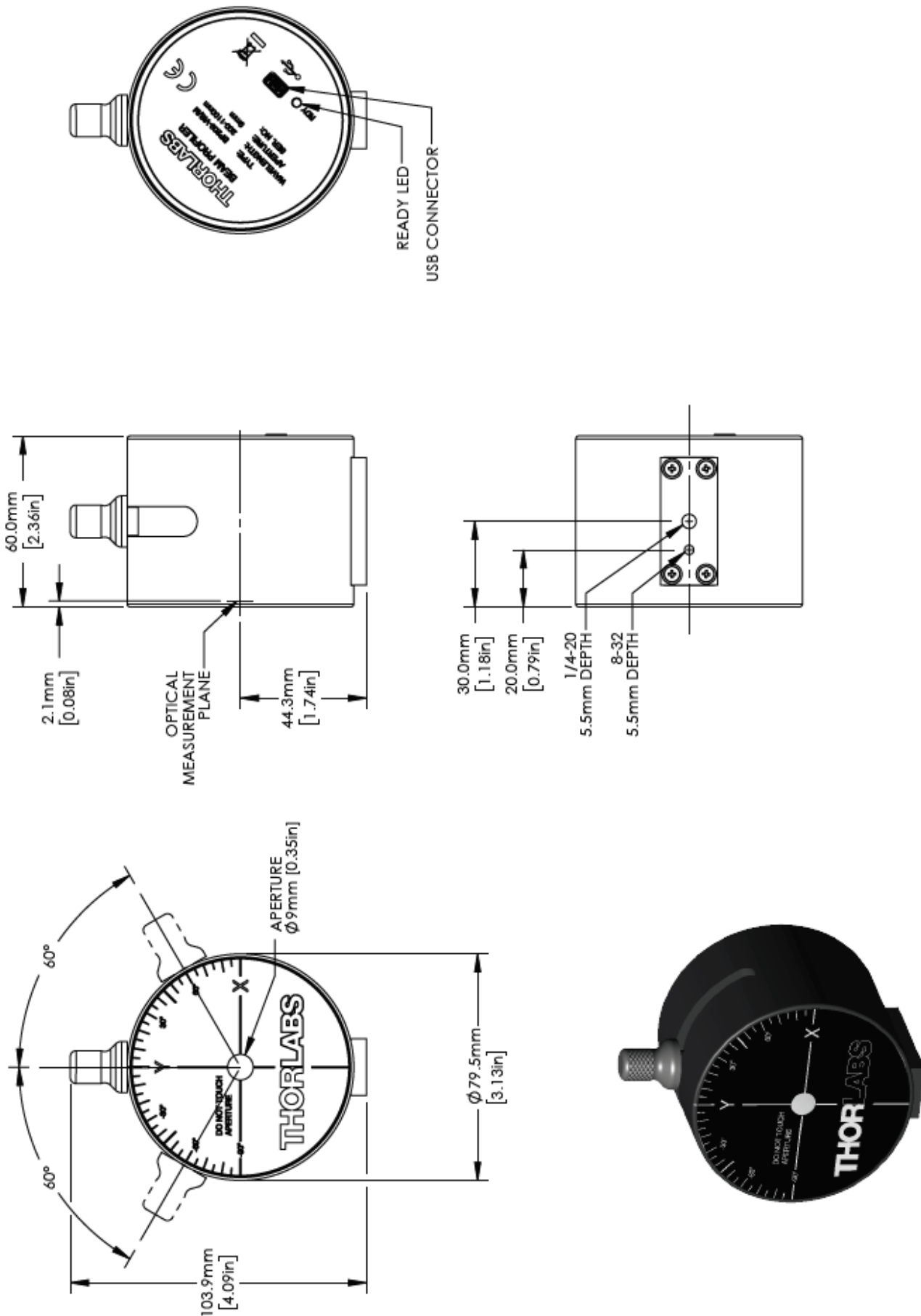

Drawing BP209 Series - Imperial Version

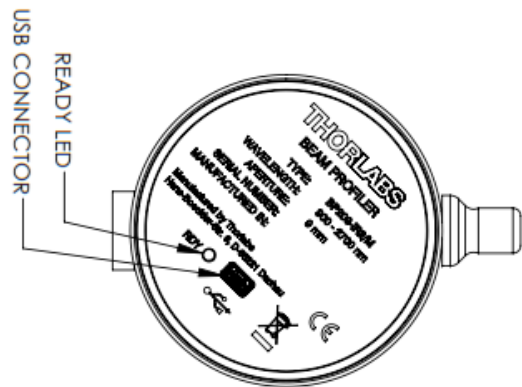
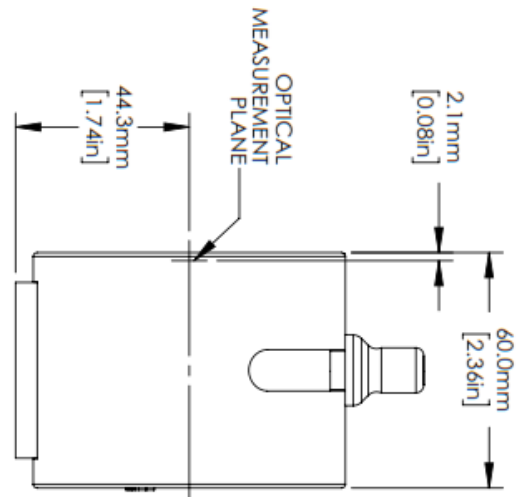
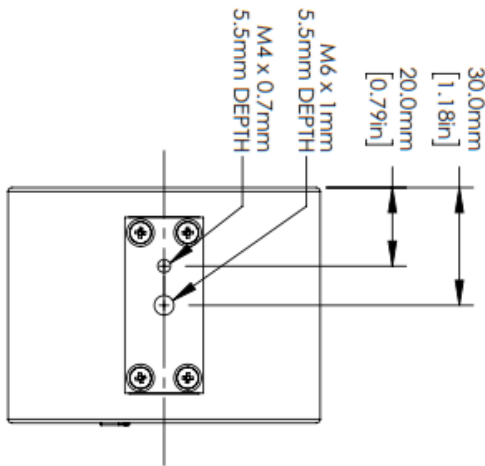
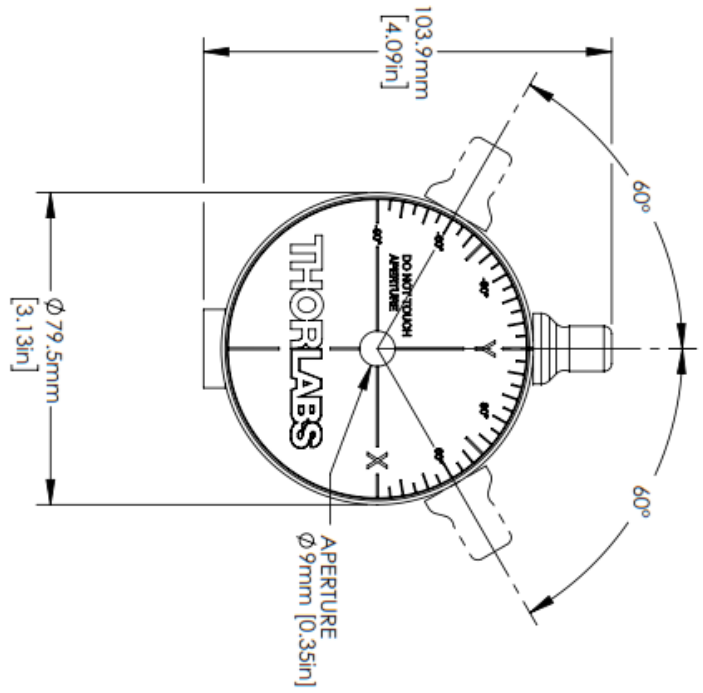

Drawing BP209 Series - Metric Version

11.8 Slit and Photodiode Position

It is required at any time, that the entire beam power enters the entrance aperture, is scanned by the slit and detected by the photodiode. Particularly for diverging beams the operator needs to know the positions and distances of these elements.

BP209-VIS

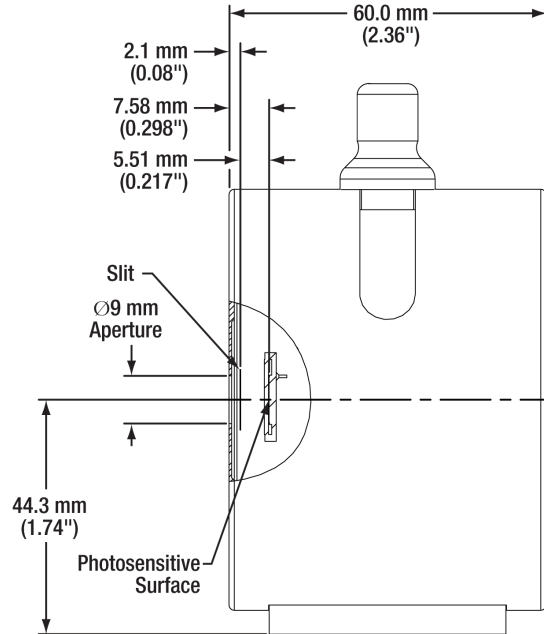

BP209IR1 and BP209-IR2 use an aspheric collimating lens between the slit and the photodiode:

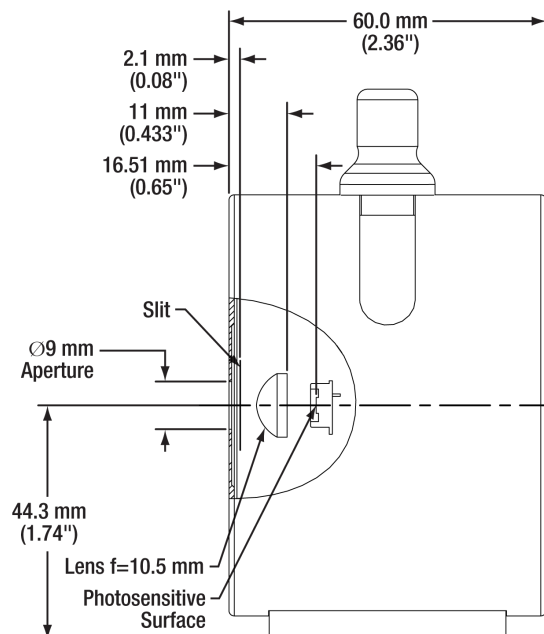

11.9 Drawing BP209 Mounting Adapter

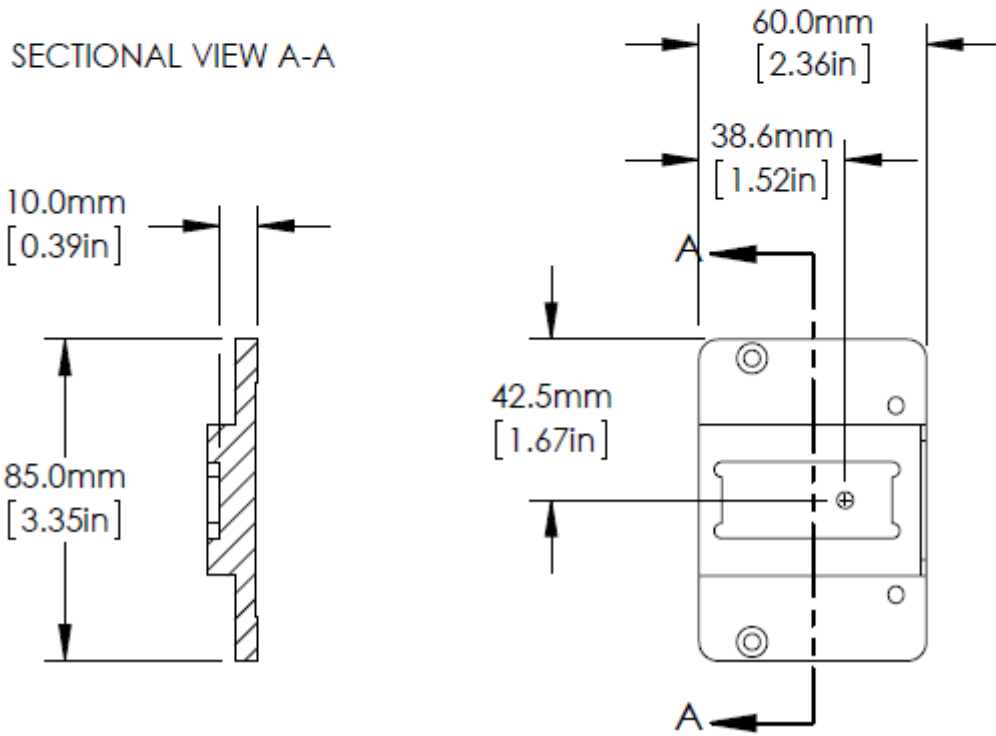
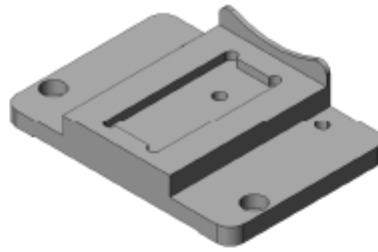

11.10 Drawing M2MS-BP209

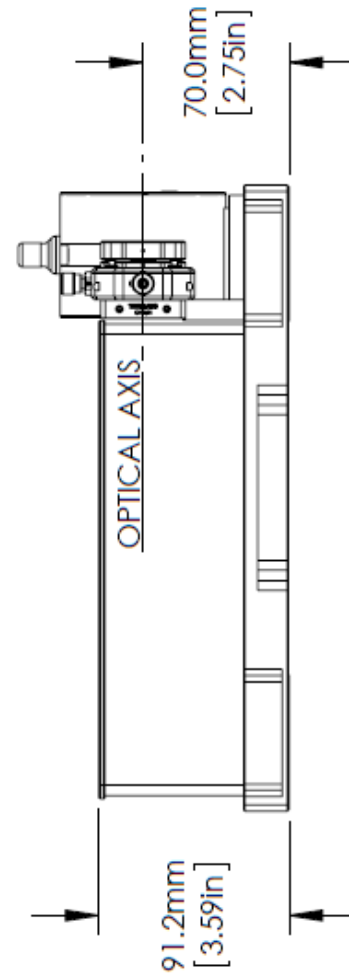
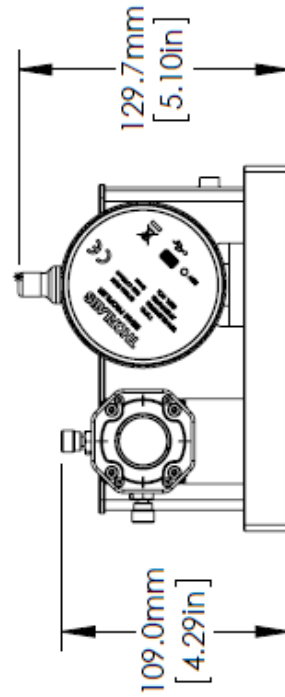
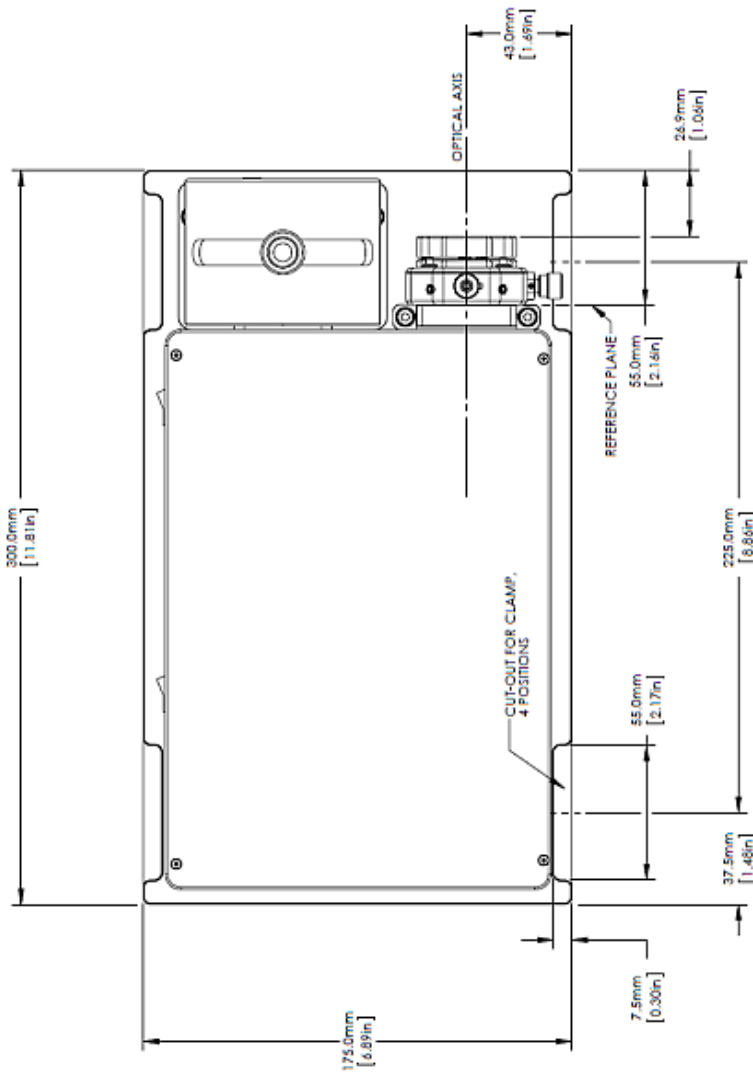

11.11 Compatibility with Older Hardware

The Beam Software is downwards compatible with the following discontinued hardware components:

- BC106N-UV, BC106N-VIS (Camera Beam Profiler)

Electrical connections and mechanical setup should be carried out as described in the appropriate documentation to this hardware, while operation is described in the manual on hand.

Older documentation can be downloaded from the Thorlabs Manual Archive at www.thorlabs.com/manuals.cfm. Open this page and enter the desired item number; be careful about correct spelling.

11.12 List of Acronyms

The following acronyms and abbreviations are used in this manual:

2D	<u>2</u> <u>D</u> imensional
3D	<u>3</u> <u>D</u> imensional
ADC	<u>A</u> nalog to <u>D</u> igital <u>C</u> onverter
AL	<u>A</u> luminum
AR	<u>A</u> nti <u>R</u> eflection
BC	<u>B</u> eam Profiler <u>C</u> amera
CA	<u>C</u> alculation <u>A</u> rea
cw	<u>C</u> ontinuous <u>W</u> ave (constant power source)
GUI	<u>G</u> raphical <u>U</u> ser <u>I</u> nterface
ND	<u>N</u> eutral <u>D</u> ensity
PC	<u>P</u> ersonal <u>C</u> omputer
FPS	<u>F</u> rames <u>P</u> er <u>S</u> econd
ROI	<u>R</u> egion <u>O</u> f <u>I</u> nterest
USB	<u>U</u> niversal <u>S</u> erial <u>B</u> us
UV	<u>U</u> ltra <u>V</u> iolet (wavelength range)
VIS	<u>V</u> ISible (wavelength range)

11.13 Safety

Attention

The safety of any system incorporating the equipment is the responsibility of the assembler of the system.

All statements regarding safety of operation and technical data in this instruction manual will only apply when the unit is operated correctly as it was designed for.

The Beam Profiler must not be operated in explosion endangered environments! To prevent the Beam Profiler from overheating, do not cover the instrument.

This precision device is only serviceable if properly packed into the complete original packaging including the plastic foam sleeves. If necessary, ask for replacement packaging. Refer servicing to qualified personnel!

Before applying power to the PC system used to operate the Beam Profiler, make sure that the protective conductor of the 3 conductor mains power cord is correctly connected to the protective earth contact of the socket outlet! Improper grounding can cause electric shock with damages to your health or even death!

The instrument must only be operated with a duly shielded and low resistance USB cable delivered by Thorlabs.

Only with written consent from Thorlabs may changes to single components be carried out or components not supplied by Thorlabs be used. Do not stick anything into the aperture in the middle of the Beam Profiler front! You may damage the thin-skinned slits, spoil the bearings of the motor and/or blockade the rotating drum because there is no covering glass in front of it.

Warning

The M2MS(-AL) M² Measurement System comes with an alignment laser that is powered by a M2MS(-AL) internal driver. Be careful when using this laser!



11.14 Certifications and Compliances

EU Declaration of Conformity

in accordance with EN ISO 17050-1:2010

We: Thorlabs GmbH

Of: Münchner Weg 1, 85232 Bergkirchen, Deutschland

in accordance with the following Directive(s):

2014/30/EU	Electromagnetic Compatibility (EMC) Directive
2011/65/EU	Restriction of Use of Certain Hazardous Substances (RoHS)

hereby declare that:

Model: **BP209 Series**

Equipment: **Slit Beam Profiler (Visible or Infrared)**

is in conformity with the applicable requirements of the following documents:

EN 61326-1	Electrical Equipment for Measurement, Control and Laboratory Use - EMC Requirements	2013
------------	---	------

and which, issued under the sole responsibility of Thorlabs, is in conformity with Directive 2011/65/EU of the European Parliament and of the Council of 8th June 2011 on the restriction of the use of certain hazardous substances in electrical and electronic equipment, for the reason stated below:

does not contain substances in excess of the maximum concentration values tolerated by weight in homogenous materials as listed in Annex II of the Directive

I hereby declare that the equipment named has been designed to comply with the relevant sections of the above referenced specifications, and complies with all applicable Essential Requirements of the Directives.

Signed:



On: 22 November 2019

Name: Bruno Gross

Position: General Manager

EDC - BP209 Series -2019-11-22



11.15 Return of Devices

This precision device is only serviceable if returned and properly packed into the complete original packaging including the complete shipment plus the cardboard insert that holds the enclosed devices. If necessary, ask for replacement packaging. Refer servicing to qualified personnel.

11.16 Manufacturer Address

Manufacturer Address Europe

Thorlabs GmbH
Münchner Weg 1
D-85232 Bergkirchen
Germany
Tel: +49-8131-5956-0
Fax: +49-8131-5956-99
www.thorlabs.de
Email: europa@thorlabs.com

EU-Importer Address

Thorlabs GmbH
Münchner Weg 1
D-85232 Bergkirchen
Germany
Tel: +49-8131-5956-0
Fax: +49-8131-5956-99
www.thorlabs.de
Email: europa@thorlabs.com

11.17 Warranty

Thorlabs warrants material and production of the BP209 Series for a period of 24 months starting with the date of shipment in accordance with and subject to the terms and conditions set forth in Thorlabs' General Terms and Conditions of Sale which can be found at:

General Terms and Conditions:

https://www.thorlabs.com/Images/PDF/LG-PO-001_Thorlabs_terms_and_%20agreements.pdf

and

https://www.thorlabs.com/images/PDF/Terms%20and%20Conditions%20of%20Sales_Thorlabs-GmbH_English.pdf

11.18 Exclusion of Liability and Copyright

Thorlabs has taken every possible care in preparing this document. We however assume no liability for the content, completeness or quality of the information contained therein. The content of this document is regularly updated and adapted to reflect the current status of the product.

All rights reserved. This document may not be reproduced, transmitted or translated to another language, either as a whole or in parts, without the prior written permission of Thorlabs. Copyright © Thorlabs 2022. All rights reserved.

Please refer to the general terms and conditions linked under [Warranty](#) .

11.19 Thorlabs Worldwide Contacts

For technical support or sales inquiries, please visit us at <https://www.thorlabs.com/locations.cfm> for our most up-to-date contact information.



USA, Canada, and South America

Thorlabs, Inc.
sales@thorlabs.com
techsupport@thorlabs.com

UK and Ireland

Thorlabs Ltd.
sales.uk@thorlabs.com
techsupport.uk@thorlabs.com

Europe

Thorlabs GmbH
europe@thorlabs.com

Scandinavia

Thorlabs Sweden AB
scandinavia@thorlabs.com

France

Thorlabs SAS
sales.fr@thorlabs.com

Brazil

Thorlabs Vendas de Fotônicos Ltda.
brasil@thorlabs.com

Japan

Thorlabs Japan, Inc.
sales@thorlabs.jp

China

Thorlabs China
chinasales@thorlabs.com

Thorlabs 'End of Life' Policy (WEEE)

Thorlabs verifies our compliance with the WEEE (Waste Electrical and Electronic Equipment) directive of the European Community and the corresponding national laws. Accordingly, all end users in the EC may return "end of life" Annex I category electrical and electronic equipment sold after August 13, 2005 to Thorlabs, without incurring disposal charges. Eligible units are marked with the crossed out "wheelie bin" logo (see right), were sold to and are currently owned by a company or institute within the EC, and are not disassembled or contaminated. Contact Thorlabs for more information. Waste treatment is your own responsibility. "End of life" units must be returned to Thorlabs or handed to a company specializing in waste recovery. Do not dispose of the unit in a litter bin or at a public waste disposal site. It is the users responsibility to delete all private data stored on the device prior to disposal.

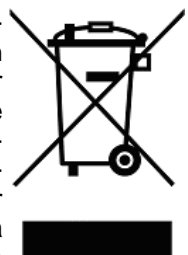

Index

	Driver Installation	13
	Duster Spray	138
	E	
	Eccentricity	142
	Ellipse fit	142
	Ellipticity	142
	Error Messages	139
	Errors	140
	Export a PDF Test Protocol	66
	F	
	Factory device settings	30
	G	
	Gaussian beam	130
	Gaussian Diameter	143
	Gaussian Intensity	143
	General Information	6
	Guidelines for Operation	63
	I	
	Image Export	66
	K	
	K factor	130
	Knife Edge Mode	74
	L	
	Lab System	141
	List of Acronyms	158
	M	
	M ² Display	97
	M ² Error Messages	111
	M ² Measurement	87, 97, 105
	M ² Measurement Results	106
	M ² Settings	99
	M ² Theory	130
	Maintenance and Repair	138
	Manual Vergence	49
	Measurement	
	MaxHold function	72
	Microsoft Excel File	66
	Mode mixture beam	130
*		
2D Reconstruction	40	
3D Profile	42	
A		
Accessories	6	
Acronyms	158	
AD Saturation	141	
Application Note	141	
ASCII Text File	66	
Astigmatism	106	
B		
Beam Diameter	141	
Beam Overlapping	53	
Beam quality measurement	77	
Beam Waist	106	
Beam Width	141	
Beam Width Clip	143	
C		
Calculation Results	45	
Cannot Connect	139	
Centroid Position	141	
Certifications and Compliances	160	
Child Windows	39	
Cleaning	138	
Connection to the PC	13	
Coordinate systems	141	
D		
Data Export	66	
Default Value	63	
Device Selection	14, 63	
Device Settings	30	
Divergence Angle	106	
Divergence Assymetry	106	
Divergence Display	123	
Divergence Measurement	115, 126	
Divergence Results	127	
Divergence Settings	125	

Mounting plate	12	slit scanning beam profiler	15
		Software Installation	13
N		Start the Application	14
NI-VISA	13	Status Bar	140
Numeric Results	45	synchronization	72
O		T	
Operating the Instrument	63	Technical Data	145
Ordering Codes	6	TEM00	130
Orientation	142	Test Protocol	66
		Time-Out	111
		Times-diffraction-limit factor M2	130
P		Total Power	141
Pass/Fail Test	65	Transformed System	141
Peak Position	141	Troubleshooting	111, 139
Performance Optimization	63	Tuning View	51
Photodiode	148, 154		
Plot Beam Stability	61	U	
Plot Gaussian Fit	58	USB Connection	13
Plot Positions	56	USB Driver Installation	13
Plot Power	57	USB Hub	13
Plots	55	USB to Serial converter	86
Position	154	V	
Power ranges	150	Version and other Informations	138
Power too high	140		
Power too low	140	W	
Preview Image	63	Waist Assymetry	106
Program Start	14	Waist diameter	130
Pulsed Laser Sources	72	Warnings	140
		Wavelength	63, 130
		Wavelength Response	148
R		X	
Raw Data Measurements	141	X / Y Profile	43
Rayleigh length	106, 130	X and Y axis	11
Region of Interest	63		
Requirements	7		
ROI	63		
Rotation mount	11		
RS232	86		
S			
Safety	159		
Save Measurement Results	66		
Save Settings	25		
scan axis	15		
Sensitivity	148		
Slit	154		



THORLABS
www.thorlabs.com
